

GHOST

2023



INHALT/INDEX

STORY TIME

| | |
|-------------------------|----|
| BRAND | 2 |
| SIDE BY SIDE | 8 |
| comMUTE | 10 |
| SUPERFIT | 12 |
| TRACTION LINK | 14 |
| FAZUA | 16 |
| BOSCH | 18 |
| RANGE | 20 |
| XLC MODULAR RAIL SYSTEM | 22 |

BIKES

| | |
|---------|-----|
| RIOT | 24 |
| LECTOR | 38 |
| NIRVANA | 50 |
| KATO | 58 |
| LANAO | 76 |
| KIDS | 86 |
| SQUARE | 118 |
| ASKET | 128 |

E-BIKES

| | |
|------------|-----|
| PATH RIOT | 140 |
| E-RIOT | 146 |
| E-ASX | 160 |
| E-TERU | 166 |
| PATH ASKET | 184 |

P&A

| | |
|-----------|-----|
| BIKEPARTS | 188 |
|-----------|-----|

INFO

| | |
|-----------------|-----|
| BIKE ANATOMIE | 218 |
| GEOMETRIEN | 220 |
| TECHNIK LEXIKON | 258 |
| EINSATZBEREICHE | 260 |



**BUILT FOR
THE ROUGH**



GHOST

***WE LIVE FOR YOU TO DOMINATE
EVERYTHING THE MOUNTAIN
HAS TO OFFER, GIVING YOU
THE PERFORMANCE, THE
ENVIRONMENT AND THE STROKE
TO ATTACK ANY ADVENTURE
WITH CONFIDENCE.***

***DEIN ZIEL IST UNSER CREDO: ALLES ZU MEISTERN, WAS DER BERG ZU BIETEN HAT.
WIR STELLEN DIE RICHTIGEN RAHMENBEDINGUNGEN, SCHÜREN DIE
BEGEISTERUNG UND BIETEN DIR DIE PERFORMANCE, UM JEDES ABENTEUER DA
DRAUSSEN SICHER ZU BEWÄLTIGEN.***

**YOUR RIDE. YOUR ENJOYMENT.
YOUR ENVIRONMENT.
YOUR HEALTH. WE SHARE THE
STOKE BY WHAT WE
CONTRIBUTE TO THE WORLD
BY MAKING OUR BIKES.
OUR GOAL WHEN WE
STARTED WAS SIMPLE.
WE WANTED A BETTER
BIKE SO WE COULD
GO OUT, EXPLORE, HAVE FUN
AND JUST DO OUR THING
WITH OUR FRIENDS. SOME
THINGS NEVER CHANGE.
GO OUT AND RIDE.**

*ES GEHT NUR UM DICH! ES IST DEIN RIDE, DEIN ABENTEUER,
DEINE UMWELT UND DEINE GESUNDHEIT. WIR TEILEN DIESE BEGEISTERUNG
MIT JEDEM BIKE, DAS WIR BAUEN, BEI ALL DEINEN ABENTEUERN. ALS WIR
ANFINGEN WAR UNSER ZIEL GANZ EINFACH: WIR WOLLTEN BESSERE BIKES
ENTWICKELN, UM RAUSZUGEHEN, UM NEUES ZU ENTDECKEN, UM SPASS ZU
HABEN UND EINFACH UNSER DING MIT UNSEREN FREUNDEN MACHEN ZU KÖNNEN.
DIESER GRUNDSATZ HAT SICH BIS HEUTE NICH GEÄNDERT: RAUSGEHEN UND BIKEN.*





**SHARE
THE STROKE**



***FUNCTION
IS KEY***



**WE KNOW OUR CUSTOMERS ARE
COMMITTED RIDERS. EVERY BIKE
WE MAKE INCORPORATES THE
IDEAL BLEND OF INGREDIENTS.
PERFECTLY TAILORED TO YOUR
NEEDS. FOR YOU IT SIMPLY
TRANSLATES TO THE BEST RIDE
OUT THERE. WE FOCUS ON
FUNCTION, DELIVERED RIGHT
WHERE IT MATTERS MOST FOR YOU.
WE AIM TO INNOVATE
WHERE IT TRULY MATTERS.
AS A RESULT YOU EXPERIENCE
IMPROVED PERFORMANCE,
BETTER CONTROL, ENHANCED
COMFORT AND LONGEVITY.**

**WIR WISSEN, DASS DU EIN 100% ENGAGIERTER BIKER BIST. UNSERE BIKES SIND
PERFEKT AUF DEINE BEDÜRFNISSE ZUGESCHNITTEN UND HABEN DIE RICHTIGE
ABSTIMMUNG FÜR JEDEN EINSATZBEREICH. FÜR DICH BEDEUTET DAS GANZ EINFACH
DAS BESTE BIKE DA DRAUSSEN. WIR FOKUSSIEREN UNS AUF FUNKTION, GENAU DORT,
WO ES FÜR DICH AM SINNVOLLSTEN IST. UNSER ZIEL IST ES, INNOVATIV ZU SEIN,
WO ES WIRKLICH NOTWENDIG IST. DU ERLEBST MEHR PERFORMANCE,
BESSERE KONTROLLE, UMFANGREICHEREN KOMFORT UND LANGLEBIGKEIT.**

GHOSH

SIDE BY SIDE

**DURING THE ENTIRE DEVELOPMENT PHASE,
THE PATH RIOT AND RIOT CF STOOD
TOGETHER. AT EYE LEVEL.
EQUALLY IMPORTANT. SIDE BY SIDE.
NO COMPROMISES. SAME SPECS ON BOTH
BIKES. FOR US, PERFORMANCE AND
HANDLING ALWAYS CAME FIRST.**

**WÄHREND DER GESAMTEN ENTWICKLUNGSPHASE GAB ES DAS PATH RIOT UND RIOT CF
NUR GEMEINSAM. AUF AUGENHÖHE. GLEICH WICHTIG. SEITE AN SEITE.
KEINE KOMPROMISSE. GLEICHE SPECS BEI BEIDEN RÄDERN.
FÜR UNS STAND PERFORMANCE UND HANDLING IMMER AN ERSTER STELLE.**



TWIN CHARACTERS

**NEWLY DESIGNED
LIGHTWEIGHT CARBON FRAME**

NEU KONZIPIERTER
LEICHTER CARBONRAHMEN



**AGILE HANDLING
ALL SIZES 29"**

AGILES FAHRVERHALTEN
ALLE GRÖSSEN 29"

NOISE MANAGEMENT

GERÄUSCHMANAGEMENT



**NO „CABLE RATTLE“
NO ENGINE NOISE**

KEIN „KABELKLAPPERN“
KEIN MOTORENGERÄUSCH

REVISED KINEMATICS

ÜBERARBEITETE KINEMATIK



**MORE PERFORMANCE
AND BETTER HANDLING**

MEHR PERFORMANCE
UND BESSERES HANDLING



**YOU DON'T HAVE TO CHOOSE.
NO ONE IS JUDGING.
JUST GO BIKING.**



COMMUTE

CHOOSE YOUR PATH.

**ADVENTURE IS EVERYWHERE.
ESCAPE THE LOUD AND HECTIC TRAFFIC
ON YOUR GETAWAY. THERE ARE MORE
POSSIBILITIES AND MORE PATHS
THAN THE ORDINARY.**

**DAS ABENTEUER IST ÜBERALL. ENTKOMME DEM LÄRM UND DER HEKTIK DES ALLTAGS.
ES GIBT MEHR MÖGLICHKEITEN UND MEHR WEGE ALS DU DIR VORSTELLEN KANNST.**

COMMUTE CHARACTERS

**NEWLY DESIGNED
LIGHTWEIGHT CARBON FRAME**

**NEU KONZIPIERTER
LEICHTER KARBONRAHMEN**



AGILE RIDE

AGILES FAHRVERHALTEN

NEW GRAVEL GEOMETRY

NEUE GRAVELGEOMETRIE



**NEXT GRAVEL LEVEL
RIDING EXPERIENCE**

NEXT GRAVEL LEVEL FAHRERLEBNIS

**SUSPENSION FORK
AND DROPPER POST**

FEDERGABEL UND DROPPER POST

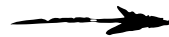

**MORE TRAVEL
FOR YOUR GRAVEL**

MORE TRAVEL FOR YOUR GRAVEL

PATHASKET



PATH ASKET PRO



PATH ASKET ADVANCED

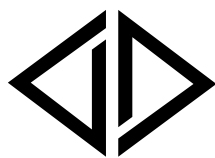

SUPER FIT
by *GHOST*

SUPERFIT ***TECHNOLOGY***

**OPTIMALE
LAUFRADGRÖSSE +**
OPTIMAL WHEEL SIZE



**ANGEPASSTE
KURBELLÄNGE +**
ADJUSTED CRANK LENGTH

DE Wie für Dich gemacht.

Für jede Körpergröße die perfekte Geometrie: Wir haben die biometrischen Daten von hunderttausend Männern und Frauen ausgewertet und festgestellt, dass die Bein- und Armlängen bei Menschen ähnlicher Größe nahezu gleich sind – und zwar unisex. Aus den relevanten Maßen errechnet der SuperFit-Algorithmus für jede Größe und jeden Fahrstil die perfekte Geometrie. Dabei definiert er nicht nur die optimale Position der Kontaktpunkte (Lenker, Pedale und Sattel), sondern berücksichtigt selbstverständlich auch den Einsatzbereich (Tour, Trail oder Race).

EN Custom-built for you.

The perfect geometry, no matter how tall you are. We analyzed the biometric data of hundreds of thousands of men and women and found that the leg and arm lengths of people of similar height are nearly identical - unisex. Based on key measurements the SuperFit algorithm calculates the perfect geometry for every height and riding style. It not only defines the optimum position of the contact points (handlebars, pedals and saddle), but also takes into account the area of use (tour, trail or race).

**+ INDIVIDUELLE
LENKERBREITE**
INDIVIDUAL BAR WIDTH

**+ ABGESTIMMTER
FEDERWEG**
MATCHING FORK TRAVEL

**+ GRÖSSEN- UND
EINSATZSPEZIFISCHE
RAHMENGEOMETRIE**
*SIZE AND RIDING TYPE
SPECIFIC FRAME GEOMETRY*



KEYFEATURES

TRACTION LINK

MAXIMALER
VORTRIEB OHNE
+ WIPPBEWEGUNG

MAXIMUM PROPULSION
WITH ANTI-SQUAT

VERTIKALES
EINFEDERN +

VERTICAL AXLE PATH

PERMANENTE
BODENHAFTUNG +

PERMANENT GRIP

TRACTION LINK

***DAS FEDERUNGSSYSTEM
FÜR ANTRIEBSNEUTRALITÄT UND
MEGA TRAKTION***

***THE SUSPENSION SYSTEM
FOR BOB-FREE PEDALING EFFICIENCY
AND TERRIFIC TRACTION***

DE TractionLink schluckt härteste Schläge genauso wie feine Unebenheiten, bügelt das Gelände weitgehend glatt und sorgt selbst in anspruchsvollsten Situationen für permanente Bodenhaftung. Das bringt zusätzliche Sicherheit und Ruhe ins Bike, spart dir Kräfte und lässt dich voll auf die Strecke konzentrieren.

EN TractionLink absorbs the hardest blows as well as fine bumps. It smooths the terrain, ensuring permanent grip even in the most demanding situations. This provides additional safety and calmness for the bike, saving you energy and allowing you to fully concentrate on your line.

NEUER FAZUA RIDE 60

**NEW FAZUA
RIDE 60**

**+ DAS KLEINSTE, LEICHTESTE,
FORTGESCHRITTENSTE
SPORTLICHE E-LIGHT-SYSTEM**

*SMALLEST AND MOST ADVANCED
SPORTIVE E-LIGHT SYSTEM*

+ MOTORGEWICHT 1,96 KG

MOTOR WEIGHT 1.96 KG

+ AKKUKAPAZITÄT 430 WH

BATTERY CAPACITY 430 WH

**+ ZUSATZAKKU
210 WH ERHÄLTLICH**

RANGE EXTENDER 210 WH AVAILABLE

+ DREHMOMENT 60 NM

TORQUE 60 NM



FAZUA APP

DE Mit der FAZUA App lassen sich die Fahrmodi komplett individualisieren und vorgefertigte Profile können direkt heruntergeladen werden.

EN With the FAZUA app, the riding modes can be completely individualized, predefined profiles can be downloaded directly and updates can be carried out wirelessly.



FAZUA TOOLBOX SOFTWARE

DE Die FAZUA Desktop Software ermöglicht dem Händler, aber auch dem Radfahrer selbst, unkompliziert Konfigurationen, Updates und Fehlerdiagnose über den eigenen Computer.

EN The FAZUA desktop Toolbox Software provides dealers and the cyclists themselves with uncomplicated configurations, updates and error diagnostics on their own computer.





FAZUA ENERGY 430 FIX

DE Mit nur 2,2 kg ermöglicht der Akku eine perfekt integrierte Rahmenlösung. Beim Bewegen des Fahrrads wird der Akku automatisch eingeschaltet.

EN At only 2.2 kg, it allows for a perfectly integrated frame solution. When the bike moves, the battery is automatically switched on.



FAZUA RING CONTROL

DE Die minimalistische RING CONTROL am Lenker lässt sich extrem intuitiv bedienen. Hier wählt der Fahrer den Fahrmodus, betätigt die Schiebehilfe oder schaltet das Licht ein. Der Blick kann somit stets auf den Weg gerichtet bleiben.

EN The minimalistic RING CONTROL on the handlebar utilizes an incredibly intuitive design. Here you can choose the riding mode, turn on the light and the walk assist – all without taking your eyes off the track.



FAZUA LED HUB

DE Die LED HUB im Oberrohr informiert mit fünf farbigen LEDs nicht nur über den Ladezustand und den gewählten Fahrmodus. Sie verfügt zudem über eine USB-C Lademöglichkeit für das Smartphone oder den Fahrradcomputer. Außerdem sitzt hier die Schnittstelle für ANT+ und Bluetooth (BLE).

EN The LED HUB with its five color LEDs informs you not only about the battery charge and your riding mode. It also features a USB-C charging option, e.g. for your smartphone or GPS device, and an interface for ANT+ and bluetooth.



FAZUA RANGE EXTENDER 210 WH

DE Lust auf mehr? Mit dem Zusatzakku kann sich der Fahrer optional 210 Wh extra Power gönnen. Dieser ergänzt die Leistung des Hauptakkus oder ersetzt diesen sogar.

EN Want more? With the Range Extender the rider gets to treat himself to an additional 210 Wh of power. This battery will supplement the main battery or even replace it.



The smart
system

FÜR ALLE
MOTOREN

FOR ALL
MOTORS



JEDES GHOST-BIKE MIT BOSCH MOTOR VERFÜGT NUN ÜBER DAS INTUITIVE SMART SYSTEM

EVERY GHOST-BIKE WITH BOSCH MOTOR
NOW FEATURES THE INTUITIVE SMART SYSTEM



E-BIKE FLOW APP

DE Nie mehr auf ein Update warten, immer wissen wann der nächste Servicetermin ansteht, all deine Tourdaten immer bei der Hand und vieles vieles mehr. Durch die neue E-Bike Flow App von Bosch, werden deine E-Bike Touren zu individuellen Erlebnissen.

EN The new E-bike Flow App from Bosch turns your e-bike tours into personalized experiences. Never wait for an update again, always know when it's time for your next service appointment, view your tour data and so much more!

KIOX 300 & LED REMOTE

DE Das Herzstück des Smart Systems von Bosch. Die Steuerzentrale. Auf das Wesentliche reduziert, kannst du so alle wichtigen Informationen auf deinem Display einsehen und leicht die Unterstützungsstufen bedienen.

EN The heart of the Bosch smart system, your mission control. Stripped down to the essentials, you can view all important data on your display, and control the support modes easily.



4A CHARGER

DE Ein Ladegerät mit vielen Vorteilen. Das kleine kompakte Ladegerät lädt schnell, ist ideal für unterwegs, sehr einfach anzuwenden und überzeugt optisch. So musst du auch bei längeren Touren nicht auf die nötige Energie verzichten.

EN A charger with many advantages. The small, compact charger charges quickly - ideal for when you are out on a ride. It is also easy to use and looks great. You will always have a power boost even on longer rides.

POWERTUBE 500 WH // 625 WH // 750 WH

DE Ein Akku der maximale Reichweite garantiert, mit einem formschönen Design und einer nutzerfreundlichen Handhabung überzeugt. Ein zuverlässiger Energielieferant, der jede Tour zu einem vollen Vergnügen macht. Je nach Einsatzgebiet erhältlich in 500 Wh, 625 Wh oder 750 Wh.

EN A battery which guarantees maximum range, beautifully designed and user-friendly. A reliable power source making every ride great fun. Depending on the field of use available in 500 Wh, 625 Wh or 750 Wh.



DRIVE UNIT PERFORMANCE, PERFORMANCE LINE CX

DE Egal für welches Kraftpaket du dich entscheidest, das Smart System ist jetzt bei allen verbauten Bosch Motoren integriert.

EN No matter what powerhouse you choose, the Bosch Smart System now comes with all built-in motors.

1

MTB EXPERIENCE

MTBs and E-Bikes which open the door to mountainbiking and more.

2

RACE

Highend, light Worldcup XC-Bikes with a unique design. Developed for worldclass athletes, marathons and weekend racers.

3

GRAVITY

Bikes with dynamic suspension systems for DH, FR, EN, AM, Trail and Touring. For endless rides, available as E- and non E-Bikes.

4

FREEDOM

Lightweight, fast and all-purpose: Gravel bikes are the "do it all" bikes and are also perfect for any kind of bikepacking adventure.

5

COMMUTE

Clean, practical and lightweight bikes for urban lifestyle as well as long distance bikes for day trips and travel adventures.

MTBs und E-Bikes, die neue
Welten eröffnen:
Mountainbiking und mehr.

*E-TERU
NIRVANA
KATO FS
KATO
LANAO
KIDS*

Hochwertige, leichte
Worldcup XC-Bikes mit
einem einzigartigen Design.
Entwickelt für Weltklasse-
Athleten, Marathons und
Wochenend-Racer.

*LECTOR
LECTOR FS*

Bikes mit dynamischen
Federungssystemen für DH, FR,
EN, AM, Trail und Touring. Für
unbegrenzt fahren, Bikes
erhältlich als E-Bike und
Nicht-E-Bike.

*E-ASX
E-RIOT
PATH RIOT
RIOT*

Leicht, schnell und
universell einsetzbar:
Gravelbikes sind die
„Alleskönner“ unter den
Fahrrädern und eignen sich
auch für jede Art von
Bikepacking-Abenteuer.

*PATH ASKET
ASKET*

Praktische und leichte
Fahrräder mit cleanem
Design für den urbanen
Lebensstil sowie
Langstreckenräder
für Tagesausflüge
und Reiseabenteuer.

*SQUARE
E-TERU EQ*

**R
A
M
G
E**

MR-S12 / MR-S13 / MR-S14 XLC MRS TheBottle Set
XLC MRS TRINKFLASCHEN SET



| Art-Nr. | |
|------------|--------|
| 2502402006 | 450 ml |
| 2502402005 | 600 ml |
| 2502402007 | 650 ml |
| 2502402008 | 700 ml |

► transparent, inkl. Fidlock Adapter
transparent, incl. Fidlock adapter

MR-S15
XLC MRS FIDLOCK RAIL



Art-Nr.
 2502408003

► nach MJ 21
after MY21

MR-S10
XLC MRS MULTIMOUNT

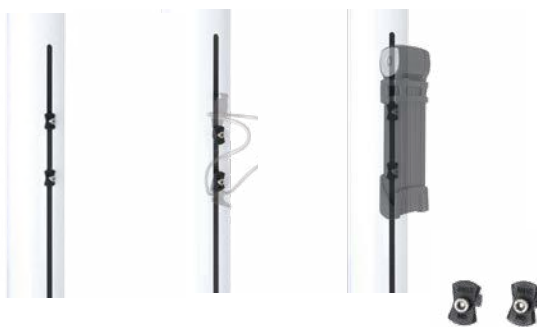

Art-Nr.
 2502408001

► schwarz, inkl. Befestigungsmaterial
black, incl. mounting material

MR-S01 / MR-S02
XLC MRS RAIL LOCK



Art-Nr.
 2502400000

► mit zweitem Schließzylinder
with second locking cylinder

2502400500

► nicht gleichschließend + 2 Schlüssel
not keyed alike + 2 keys

MR-S03

XLC MRS CABLE LOCK



Art-Nr.

2502400600

► 100cm, Ø12 mm

MR-S04

XLC MRS CHAIN LOCK



Art-Nr.

2502400700

► 85 cm, 2,9"

MR-S17

XLC MRS BOTTLEBAG



Art-Nr.

2502408005

schwarz, inkl.
► Befestigungsmaterial
black, incl. mounting material



MR-S16 XLC MRS railbag framebag-set

XLC MRS RAILBAG TASCHEN-SET



Art-Nr.

2502404010 S

2502404011 M

2502404012 L

► inkl. FidLock
base- & railadapter
incl. fidlock
base- & railadapter

MR-S11

XLC MRS KITRACK



Art-Nr.

2502408002

► schwarz, inkl.
Befestigungsmaterial
black, incl.
mounting material

BIKES

RIOT

LECTOR

NIRVANA

KATO

LANAO

KIDS

SQUARE

ASKET

dark grey / black - matt

SUPER FIT
by GHOST



RIOT EN FULL PARTY

| | | |
|---------------------------------------|---|---|
| RIOT AL | Shimano XT SL-M8100 | WTB Volt |
| Fox 38 Performance Elite GRIP2 170 mm | Race Face Aeffect R 32T | Acros BlockLock 135° AZX-582 |
| Fox DHX2 Performance Elite 160 mm | Shimano SLX CS-M7100 10-51 | Race Face BSA 68/73 |
| Syntace Megaforce2 Dia. 31.8 mm | Formula Cura 4 203 mm Disc | SRAM UDH |
| Syntace Vector 7075 high20 780 mm | Syntace V30 15x110 mm // Syntace V30 12x148 mm | WTB Wafel |
| Shimano XT RD-M8100 12-S | Eightpins hydraulic 34.9 mm | Maxxis Assegai 3C MaxxGrip Exo+ 2.5 // Maxxis Minion DHR II 3C MaxxTerra Double Down 2.4 |

| GRÖSSE | ARTIKELNUMMER | LAUFRADGRÖSSE |
|--------|---------------|---------------|
| S | 93R11061 | 27.5 |
| M | 93R11062 | 29 |
| L | 93R11063 | 29 |
| XL | 93R11064 | 29 |







black / marzocchi red - matt / glossy



SUPER FIT
by GHOST



RIOT EN PRO

RIOT AL

Marzocchi Bomber Z1 170 mm

Marzocchi Bomber CR 160 mm

Ground Fiftyone Dia. 31.8 mm

Ground Fiftyone Dia. 31.8 mm 760/15 (S) 780/25 (M-XL)

Shimano XT RD-M8100 12-S

Shimano XT SL-M8100

Shimano SLX FC-M7100 32T

Shimano XT CS-M8100 10-51

Shimano Deore BR-M6120 203 mm Disc

Eightpins hydraulic 34.9 mm

WTB Volt

Acros Blocklock 135° AZX-582

Shimano BB-MT800

SRAM UDH

WTB Wafel

Maxxis Assegai 3C MaxxGrip Exo+ 2.5 (S 27,5"; M-XL 29") // Maxxis Minion DHR II 3C MaxxTerra Double Down 2.4 (S 27,5"; M-XL 29")

WTB ST i30 // WTB ST i30

DT Swiss 370 Classic 15x110 mm

DT Swiss 370 Classic 12x148 mm

GRÖSSE ARTIKELNUMMER LAUFRADGRÖSSE

| | | |
|----|----------|--|
| S | 31R11048 | |
| M | 31R11049 | |
| L | 31R11050 | |
| XL | 31R11051 | |





met. rust dark red / light dust - matt



SUPER FIT
by GHOST



RIOT EN ESSENTIAL

RIOT AL

Rock Shox Yari RC 170 mm

Rock Shox Super Deluxe Coil Select R 160 mm

Ground Fiftyone Dia. 31.8 mm

Ground Fiftyone Dia. 31.8 mm 760/15 (S) 780/25 (M-XL)

SRAM GX Eagle 12-S

SRAM NX Eagle

Truvativ Descendant 6K Eagle 32T

SRAM PG-1230 11-50

SRAM Code R 200 mm Disc

Ghost Alpha 1 34.9 mm 125 (S) 150 (M) 170 (L/XL)

WTB Volt

Acros Blocklock 135° AZX-582

SRAM DUB BSA

SRAM UDH

WTB Wafel

Maxxis Assegai 3C MaxxGrip Exo+ 2.5 (S 27,5"; M-XL 29") //
Maxxis Minion DHR II 3C MaxxTerra Double Down 2.4 (S 27,5";
M-XL 29")

WTB ST i30 //
WTB ST i30

Shimano HB-MT400-B 15x110 mm

Shimano FH-MT400-B 12x148 mm

GRÖSSE ARTIKELNUMMER LAUFRADGRÖSSE

| | | |
|----|----------|------|
| S | 31R11042 | 27.5 |
| M | 31R11043 | 29 |
| L | 31R11044 | 29 |
| XL | 31R11045 | 29 |





warm grey / dark chocolate - glossy



SUPER FIT
by GHOST



RIOT AM FULL PARTY

RIOT CF

Fox 38 Float Factory GRIP2 160 mm

Fox Float X2 Factory 140 mm

Ground Fiftyone Dia. 31.8 mm

Ground Fiftyone Dia. 31.8 mm 760/15 (S) 800/27 (M-XL)

Shimano XT RD-M8100 12-S

Shimano SLX SL-M7100

Shimano FC-MT512 32T

Shimano SLX CS-M7100 10-51

Formula Cura 4 203 mm Disc

Syntace V30 15x110 mm //
Syntace V30 12x148 mm

Eightpins hydraulic 34.9 mm

WTB Volt

Acros Blocklock 135° AZX-582

Shimano BSA

SRAM UDH

WTB Wafel

Maxxis Assegai 3C MaxxTerra Exo+ 2.6 //
Maxxis Dissector 3C MaxxGrip Double Down 2.4

GRÖSSE ARTIKELNUMMER LAUFRADGRÖSSE

| | | |
|----|----------|----|
| S | 31R11018 | 29 |
| M | 31R11019 | 29 |
| L | 31R11020 | 29 |
| XL | 31R11021 | 29 |



grey 1 / pearl light grey - glossy

SUPER FIT
by GHOST



RIOT AM PRO

| | | |
|---|------------------------------|---|
| RIOT CF | Shimano FC-MT512 32T | SRAM UDH |
| Rock Shox ZEB Base 160 mm | Shimano Deore CS-M6100 10-51 | WTB Wafel |
| Rock Shox Super Deluxe Select+ RT 140 mm | Formula Cura 4 203 mm Disc | Maxxis Assegai 3C MaxxGrip Exo+ 2.5 // Maxxis Dissector 3C MaxxGrip Double Down 2.4 |
| Ground Fiftyone Dia. 31.8 mm | Eightpins hydraulic 34.9 mm | WTB ST Light i30 // WTB ST Light i30 |
| Ground Fiftyone Dia. 31.8 mm 760/15 (S) 800/27 (M-XL) | WTB Volt | DT Swiss 370 Classic 15x110 mm |
| Shimano XT RD-M8100 12-S | Acros Blocklock 135° AZX-582 | DT Swiss 370 Classic 12x148 mm |
| Shimano SLX SL-M7100 | Shimano BSA | |

| GRÖSSE | ARTIKELNUMMER | LAUFRADGRÖSSE |
|--------|---------------|---------------|
| S | 31R11012 | 29 |
| M | 31R11013 | 29 |
| L | 31R11014 | 29 |
| XL | 31R11015 | 29 |



black / super light green - matt

SUPER FIT
by GHOST



RIOT AM UNIVERSAL

| | | |
|---|--|---|
| RIOT AL | SRAM GX Eagle 32T | SRAM UDH |
| Rock Shox Lyrik Select 160 mm | SRAM PG-1230 11-50 | WTB Wafel |
| Rock Shox Super Deluxe Select+ RT 150 mm | SRAM G2 RSC 200 mm | Maxxis Minion DHF 3C MaxxTerra Exo+ 2.5 (S 27.5"; M-XL 29") // Maxxis Minion DHR II 3C MaxxTerra Exo+ 2.4 (S 27.5"; M-XL 29") |
| Ground Fiftyone Dia. 31.8 mm | Ghost Alpha 1 34.9 mm 125 (S) 150 (M) 170 (L/XL) | WTB ST i30 // WTB ST i30 |
| Ground Fiftyone Dia. 31.8 mm 760/15 (S) 780/25 (M-XL) | WTB Volt | Shimano HB-MT400-B 15x110 mm |
| SRAM GX Eagle 12-S | Acros Blocklock 135° AZX-582 | Shimano FH-MT400-B 12x148 mm |
| SRAM GX Eagle | SRAM DUB BSA | |

| GRÖSSE | ARTIKELNUMMER | LAUFRADGRÖSSE |
|--------|---------------|---------------|
| S | 31R11036 | 27.5 |
| M | 31R11037 | 29 |
| L | 31R11038 | 29 |
| XL | 31R11039 | 29 |



black / dark grey - matt

SUPER FIT
by GHOST



RIOT AM ESSENTIAL

| | | |
|---|--|---|
| RIOT AL | Shimano SLX FC-M7100 32T | SRAM UDH |
| Fox 36 Float Rhythm 160 mm | Shimano Deore CS-M6100 10-51 | WTB Wafel |
| Fox Float X Performance 150 mm | Shimano BR-MT520 203 mm Disc | Maxxis Minion DHF 3C MaxxTerra Exo+ 2.5 (S 27.5"; M-XL 29") // Maxxis Minion DHR II 3C MaxxTerra Exo+ 2.4 (S 27.5"; M-XL 29") |
| Ground Fiftyone Dia. 31.8 mm | Ghost Alpha 1 34.9 mm 125 (S) 150 (M) 170 (L/XL) | WTB ST i30 // WTB ST i30 |
| Ground Fiftyone Dia. 31.8 mm 760/15 (S) 780/25 (M-XL) | WTB Volt | Shimano HB-MT400-B 15x110 mm |
| Shimano XT RD-M8100 12-S | Acros BlockLock 135° AZX-582 | Shimano FH-MT410-B 12x148 mm |
| Shimano SLX SL-M7100 | Shimano BB-MT800 | |

| GRÖSSE | ARTIKELNUMMER | LAUFRADGRÖSSE |
|--------|---------------|---------------|
| S | 31R11030 | 27.5 |
| M | 31R11031 | 29 |
| L | 31R11032 | 29 |
| XL | 31R11033 | 29 |



carbon / met. dirty blue - matt

SUPER FIT
by GHOST



RIOT TRAIL FULL PARTY

| | | |
|---|--|---|
| RIOT CF | Shimano SLX SL-M7100 | WTB Volt |
| Fox 36 Float Factory FIT4 150 mm | Shimano FC-MT512 32T | Acros Blocklock 135° AZX-582 |
| Fox Float X Factory 140 mm | Shimano SLX CS-M7100 10-51 | Shimano BSA |
| Ground Fiftyone Dia. 31.8 mm | Formula Cura 4 203 mm Disc | SRAM UDH |
| Ground Fiftyone Dia. 31.8 mm 760/15 (S) 800/27 (M-XL) | Syntace V30 15x110 mm // Syntace V30 12x148 mm | WTB Wafel |
| Shimano XT RD-M8100 12-S | Eightpins hydraulic 34.9 mm | Maxxis Assegai 3C MaxxGrip Exo+ 2.5 // Maxxis Dissector 3C MaxxGrip Double Down 2.4 |

| GRÖSSE | ARTIKELNUMMER | LAUFRADGRÖSSE |
|--------|---------------|---------------|
| S | 31R11006 | 29 |
| M | 31R11007 | 29 |
| L | 31R11008 | 29 |
| XL | 31R11009 | 29 |



carbon / light kaki - matt

SUPER FIT
by GHOST



RIOT TRAIL PRO

RIOT CF

Rock Shox Lyrik Select 150 mm

Rock Shox Super Deluxe Select+ RT 140 mm

Ground Fiftyone Dia. 31.8 mm

Ground Fiftyone Dia. 31.8 mm 760/15 (S) 800/27 (M-XL)

Shimano XT RD-M8100 12-S

Shimano SLX SL-M7100

Shimano FC-MT512 32T

Shimano Deore CS-M6100 10-51

Formula Cura 4 203 mm Disc

Eightpins hydraulic 34.9 mm

WTB Volt

Acros Blocklock 135° AZX-582

Shimano BSA

SRAM UDH

WTB Wafel

Maxxis Assegai 3C MaxxGrip Exo+ 2.5 //
Maxxis Dissector 3C MaxxGrip Double Down 2.4

WTB ST Light i30 //
WTB ST Light i30

DT Swiss 370 Classic 15x110 mm

DT Swiss 370 Classic 12x148 mm

| GRÖSSE | ARTIKELNUMMER | LAUFRADGRÖSSE |
|--------|---------------|---------------|
| S | 31R11000 | 29 |
| M | 31R11001 | 29 |
| L | 31R11002 | 29 |
| XL | 31R11003 | 29 |



dark grey / rusty orange - matt

SUPER FIT
by GHOST



RIOT TRAIL ESSENTIAL

| | | |
|---|--|--|
| RIOT AL | Shimano SLX FC-M7100 32T | SRAM UDH |
| Fox 34 Float Rhythm 140 mm | Shimano SLX CS-M7100 10-51 | WTB Wafel |
| Fox Float DPS Performance LV EVOL 140 mm | Shimano BR-MT520 180 mm Disc | Schwalbe Nobby Nic Super Ground Addix Speedgrip 2.4 (S 27,5"; M-XL 29") // Schwalbe Nobby Nic Super Ground Addix Speedgrip 2.4 (S 27,5"; M-XL 29") |
| Ground Fiftyone Dia. 31.8 mm | Ghost Alpha 1 34,9 mm 125 (S) 150 (M) 170 (L/XL) | WTB ST Light i30 // WTB ST Light i30 |
| Ground Fiftyone Dia. 31.8 mm 760/15 (S) 780/25 (M-XL) | WTB Volt | Shimano HB-MT400-B 15x110 mm |
| Shimano XT RD-M8100 12-S | Acros Blocklock 135° AZX-582 | Shimano FH-MT410-B 12x148 mm |
| Shimano SLX SL-M7100 | Shimano BB-MT800 | |

| GRÖSSE | ARTIKELNUMMER | LAUFRADGRÖSSE |
|--------|---------------|---------------|
| S | 31R11024 | 27,5 |
| M | 31R11025 | 29 |
| L | 31R11026 | 29 |
| XL | 31R11027 | 29 |





dirty blue metallic / black - glossy / matt



SUPER FIT
by GHOST



RIOT TRAIL

RIOT AL

Rock Shox Recon Silver RL 140 mm

SR Suntour Edge LOR8 140 mm

Ground Fiftyone Dia. 31.8 mm

Ground Fiftyone Dia. 31.8 mm
760/15 (S) 780/15 (M-L) 780/40 (XL)

Shimano XT RD-M8100 12-S

Shimano SLX SL-M7100

Shimano Deore FC-M6100 32T

Shimano SLX CS-M7100 10-51

Shimano BR-MT500 180 mm Disc

Limotec Alpha 1 34.9 mm
125 (S) 150 (M) 170 (L/XL)

WTB Volt

Acros BlockLock 135° AZX-582

Shimano BB-MT800

SRAM UDH

WTB Wafel

Maxxis Minion DHF 3C MaxxTerra Exo 2.3 //
Maxxis Aggressor Exo 2.3

WTB ST i25 //
WTB ST i25

Shimano HB-MT400-B 15x110 mm

Shimano FH-MT510-B 12x148 mm

| GRÖSSE | ARTIKELNUMMER | LAUFRADGRÖSSE |
|--------|---------------|---------------|
| S | 93R11007 | 27.5 |
| M | 93R11008 | 29 |
| L | 93R11009 | 29 |
| XL | 93R11010 | 29 |



BIKES

RIOT

LECTOR

NIRVANA

KATO

LANAO

KIDS

SQUARE

ASKET

carbon / met. red - glossy

SUPER FIT
by GHOST



LECTOR FS SF WORLD CUP

LECTOR FS LC

Rock Shox SID SL Ultimate 100 mm (XS-S) 120 mm (M-XL)

Rock Shox SIDLuxe Ultimate Remote 100 mm (XS-S) 120 mm (M-XL)

Syntace Megaforce2 Dia. 31.8 mm

Syntace Vector Carbon Rise 5 mm Dia. 31.8 mm 700 mm (XS) 720 mm (S) 740 mm (M-L) 760 mm (XL)

SRAM XX1 Eagle AXS 12-S

SRAM Eagle AXS Controller

SRAM XX1 Eagle 32T

SRAM XG 1299 10-52

SRAM Level Ultimate 180 mm Disc

Ghost Carbon Wheelset 26 mm 15x110 mm // Ghost Carbon Wheelset 26 mm 12x148 mm

Eightpins mechanical 34.9 mm

Selle Italia SLR Boost

Acros Blocklock AZX-220-R4

SRAM Pressfit DUB

SRAM UDH

SRAM Twist Lock

Maxxis Aspen Exo 29x2.25 // Maxxis Aspen Exo 29x2.25

| GRÖSSE | ARTIKELNUMMER | LAUFRADGRÖSSE |
|--------|---------------|---------------|
| XS | 31LE2029 | 29 |
| S | 31LE2030 | 29 |
| M | 31LE2031 | 29 |
| L | 31LE2032 | 29 |
| XL | 31LE2033 | 29 |



pearl dark blue / super light green - matt



SUPER FIT
by GHOST



LECTOR FS SF PRO

| | | |
|--|--|--|
| LECTOR FS LC | Shimano XTR SL-M9100 | Selle Italia SLR Boost |
| Fox 34 Float SC Factory FIT4 Remote 100 mm (XS-S) 120 mm (M-XL) | Race Face Next SL 32T | Acros Blocklock AZX-220-R4 |
| Fox Float DPS Factory Remote 100 mm (XS-S) 120 mm (M-XL) | Shimano XTR CS-M9100 10-51 | Race Face Pressfit |
| Ground Fiftyone Dia. 31.8 mm | Shimano XTR BR-M9100 180 mm Disc | SRAM UDH |
| Ground Fiftyone Dia. 31.8 mm 700 mm (XS) 720 mm (S) 740 mm (M-L) 760 mm (XL) | Ghost Carbon Wheelset 26 mm 15x110 mm // Ghost Carbon Wheelset 26 mm 12x148 mm | ESI Grip Racer's Edge |
| Shimano XTR RD-M9100 12-S | Eightpins mechanical 34.9 mm | Maxxis Recon Race Exo 2.35 // Maxxis Recon Race Exo 2.35 |

| GRÖSSE | ARTIKELNUMMER | LAUFRADGRÖSSE |
|--------|---------------|---------------|
| XS | 31LE2022 | 29 |
| S | 31LE2023 | 29 |
| M | 31LE2024 | 29 |
| L | 31LE2025 | 29 |
| XL | 31LE2026 | 29 |



carbon / met. petrol - glossy

SUPER FIT
by GHOST



LECTOR FS SF ADVANCED

| | | |
|--|--|--|
| LECTOR FS LC | SRAM X01 Eagle | Selle Italia SLR Boost |
| Rock Shox SID Select+ RL R 100 mm (XS-S) 120 mm (M-XL) | SRAM X01 Eagle 32T | Acros Blocklock AZX-220-R4 |
| Rock Shox SIDLuxe Select+ RL 100 mm (XS-S) 120 mm (M-XL) | SRAM XG 1275 10-52 | SRAM Pressfit DUB |
| Ground Fiftyone Dia. 31.8 mm | Formula Cura 2 180 mm Disc | GW UDH |
| Ground Fiftyone Dia. 31.8 mm 700 mm (XS) 720 mm (S) 740 mm (M-L) 760 mm (XL) | Syntace W28i 15x110 mm // Syntace W28i 12x148 mm | ESI Grip Racer's Edge |
| SRAM X01 Eagle 12-S | Eightpins mechanical 34.9 mm | Maxxis Ikon 3C MaxxSpeed Exo 2.35 // Maxxis Ikon 3C MaxxSpeed Exo 2.35 |

| GRÖSSE | ARTIKELNUMMER | LAUFRADGRÖSSE |
|--------|---------------|---------------|
| XS | 31LE2015 | 29 |
| S | 31LE2016 | 29 |
| M | 31LE2017 | 29 |
| L | 31LE2018 | 29 |
| XL | 31LE2019 | 29 |



carbon / riot red - glossy

SUPER FIT
by GHOST



LECTOR FS SF UNIVERSAL

LECTOR FS LC

Rock Shox SID Select+ RL R 100 mm (XS-S) 120 mm (M-XL)

Rock Shox SIDLuxe Select+ RL 100 mm (XS-S) 120 mm (M-XL)

Ground Fiftyone Dia. 31.8 mm

Ground Fiftyone Dia. 31.8 mm 700 mm (XS) 720 mm (S) 740 mm (M-L) 760 mm (XL)

SRAM X01 Eagle 12-S

SRAM GX Eagle

Truvativ Stylo 6K 32T

SRAM XG 1275 10-52

SRAM Level TLM 180 / 160 mm Disc

Syntace V30 15x110 mm //
Syntace V30 12x148 mm

Eightpins hydraulic 34.9 mm

Selle Italia SLR Boost

Acros Blocklock AZX-220-R4

SRAM Pressfit DUB

GW UDH

WTB Trail II

Maxxis Ikon 3C MaxxSpeed Exo 2.35 //
Maxxis Ikon 3C MaxxSpeed Exo 2.35

| GRÖSSE | ARTIKELNUMMER | LAUFRADGRÖSSE |
|--------|---------------|---------------|
| XS | 31LE2008 | 29 |
| S | 31LE2009 | 29 |
| M | 31LE2010 | 29 |
| L | 31LE2011 | 29 |
| XL | 31LE2012 | 29 |



carbon / dark grey - glossy



SUPER FIT
by GHOST



LECTOR FS SF ESSENTIAL

| | | |
|--|--|--|
| LECTOR FS LC | Shimano Deore SL-M6100 | Selle Italia X3 Boost |
| Fox 34 Float SC Performance Remote 100 mm (XS-M) 120 mm (L-XL) | Shimano FC-MT510 32T | Acros Blocklock AZX-220-R4 |
| Fox Float DPS Performance Elite Remote 100 mm (XS-S) 120 mm (M-XL) | Shimano Deore CS-M6100 10-51 | Shimano BB-MT800 |
| Ground Fiftyone Dia. 31.8 mm | Formula Cura 2 180 mm Disc | GW UDH |
| Ground Fiftyone Dia. 31.8 mm 700 mm (XS) 720 mm (S) 740 mm (M-L) 760 mm (XL) | Syntace V30 15x110 mm // Syntace V30 12x148 mm | WTB Trail II |
| Shimano XT RD-M8100 12-S | GND 51 Carbon 34.9 mm | Schwalbe Racing Ralph Performance 2.25 // Schwalbe Racing Ralph Performance 2.25 |

| GRÖSSE | ARTIKELNUMMER | LAUFRADGRÖSSE |
|--------|---------------|---------------|
| XS | 31LE2001 | 29 |
| S | 31LE2002 | 29 |
| M | 31LE2003 | 29 |
| L | 31LE2004 | 29 |
| XL | 31LE2005 | 29 |





LECTOR SF WORLD CUP REPLICA

- LECTOR UC

- Rock Shox SID SL Select
100 mm (XS-M) 120 mm (L-XL)

- Ground Fiftyone Dia. 31.8 mm

- Ground Fiftyone Dia. 31.8 mm
700 mm (XS) 720 mm (S) 740 mm (M-L) 760 mm (XL)

- SRAM X01 Eagle 12-S

- SRAM X01 Eagle

- Truvativ Stylo 6K 32T

- SRAM XG 1295 10-52

- SRAM Level TL 180 / 160 mm Disc

- Syntace V25 15x110 mm //
Syntace V25 12x148 mm

- Eightpins mechanical 34.9 mm

- Selle Italia SLR Boost

- Acros Blocklock AZX-220-R4

- Sram Pressfit DUB

- FRHG0025

- ESI Grip Racer's Edge

- Maxxis Aspen Exo 29x2.25 //
Maxxis Aspen Exo 29x2.25

| GRÖSSE | ARTIKELNUMMER | LAUFRADGRÖSSE |
|--------|---------------|---------------|
| XS | 93LE1301 | 29 |
| S | 93LE1302 | 29 |
| M | 93LE1303 | 29 |
| L | 93LE1304 | 29 |
| XL | 93LE1305 | 29 |



light mint pearl / bright blue - matt / glossy



SUPER FIT
by GHOST



LECTOR SF ADVANCED

LECTOR UC

Fox 34 Float SC Performance Elite FIT4 Remote
100 mm (XS-M) 120 mm (L-XL)

Ground Fiftyone Dia. 31.8 mm

Ground Fiftyone Dia. 31.8 mm
700 mm (XS) 720 mm (S) 740 mm (M-L) 760 mm (XL)

Shimano XT RD-M8100 12-S

Shimano SLX SL-M7100

Shimano SLX FC-M7100 32T

Shimano SLX CS-M7100 10-51

Shimano SLX BR-M7100 180/160 mm Disc

Syntace V25 15x110 mm //
Syntace V25 12x148 mm

Eightpins hydraulic 34.9 mm

Selle Italia SLS

Acros Blocklock AZX-220-R4

SRAM Pressfit DUB

FRHG0025

ESI Grip Racer's Edge

Schwalbe Racing Ralph Performance 29x2.25 //
Schwalbe Racing Ralph Performance 29x2.25

| GRÖSSE | ARTIKELNUMMER | LAUFRADGRÖSSE |
|--------|---------------|---------------|
| XS | 93LE1027 | 29 |
| S | 93LE1028 | 29 |
| M | 93LE1029 | 29 |
| L | 93LE1030 | 29 |
| XL | 93LE1031 | 29 |





raw carbon / riot red - glossy / matt



SUPER FIT
by GHOST



LECTOR SF UNIVERSAL

LECTOR LC

Rock Shox SID SL Select RL
100 mm (XS-M) 120 mm (L-XL)

Ground Fiftyone Dia. 31.8 mm

Ground Fiftyone Dia. 31.8 mm
700 mm (XS) 720 mm (S) 740 mm (M-L) 760 mm (XL)

SRAM X01 Eagle 12-S

SRAM GX Eagle

Truvativ Stylo 6K 32T

SRAM XG 1275 10-52

SRAM Level TL 180 / 160 mm Disc

Syntace V25 15x110 mm //
Syntace V25 12x148 mm

GND 51 Carbon 34.9 mm

Selle Italia SLS

Acros Blocklock AZX-220-R4

SRAM Pressfit DUB

FRHG0025

WTB Trail II

Maxxis Ikon 3C MaxxSpeed Exo 29x2.35 //
Maxxis Ikon 3C MaxxSpeed Exo 29x2.35

| GRÖSSE | ARTIKELNUMMER | LAUFRADGRÖSSE |
|--------|---------------|---------------|
| XS | 93LE1021 | 29 |
| S | 93LE1022 | 29 |
| M | 93LE1023 | 29 |
| L | 93LE1024 | 29 |
| XL | 93LE1025 | 29 |





raw carbon / blue - matt / glossy



SUPER FIT
by GHOST



LECTOR SF ESSENTIAL

LECTOR LC

Fox 34 Float SC Performance Remote
100 mm (XS-M) 120 mm (L-XL)

Ground Fiftyone Dia. 31.8 mm

Ground Fiftyone Dia. 31.8 mm
700 mm (XS) 720 mm (S) 740 mm (M-L) 760 mm (XL)

Shimano SLX RD-M7100 12-S

Shimano Deore SL-M6100

Shimano FC-MT511 32T

Shimano Deore CS-M6100 10-51

Shimano SLX BR-M7000 / BR-M7110 180/160 mm Disc

GND 51 Carbon 34.9 mm

Selle Italia SLS

Acros Blocklock AZX-220-R4

Shimano BB-MT800

FRHG0025

WTB Trail II

Schwalbe Racing Ralph Performance 29x2.25 //
Schwalbe Racing Ralph Performance 29x2.25

WTB ST Light i25 //
WTB ST Light i25

Shimano HB-MT410-B 15x110 mm

Shimano FH-MT410-B 12x148 mm

| GRÖSSE | ARTIKELNUMMER | LAUFRADGRÖSSE |
|--------|---------------|---------------|
| XS | 93LE1015 | 29 |
| S | 93LE1016 | 29 |
| M | 93LE1017 | 29 |
| L | 93LE1018 | 29 |
| XL | 93LE1019 | 29 |





light grey / black - glossy / matt



SUPER FIT
by GHOST



LECTOR SF

LECTOR LC

Rock Shox Recon Gold RL Remote
100 mm (XS-M) 120 mm (L-XL)

Ground Fiftyone Dia. 31.8 mm

Ground Fiftyone Dia. 31.8 mm
700 mm (XS) 720 mm (S) 740 mm (M-L) 760 mm (XL)

SRAM SX Eagle 12-S

SRAM SX Eagle

Truvativ Stylo 6K 32T

SRAM PG-1210 11-50

Formula Cura 2 180/160 mm Disc

GND 51 Carbon 34.9 mm

Selle Italia SLS

Acros Blocklock AZX-220-R4

SRAM Pressfit

FRHG0025

WTB Trail II

Schwalbe Racing Ralph Performance 29x2.25 //
Schwalbe Racing Ralph Performance 29x2.25

WTB ST Light i25 //
WTB ST Light i25

Shimano HB-MT410-B 15x110 mm

Shimano FH-MT400-B 12x148 mm

| GRÖSSE | ARTIKELNUMMER | LAUFRADGRÖSSE |
|--------|---------------|---------------|
| XS | 93LE1008 | 29 |
| S | 93LE1009 | 29 |
| M | 93LE1010 | 29 |
| L | 93LE1011 | 29 |
| XL | 93LE1012 | 29 |



BIKES



RIOT

LECTOR

NIRVANA

KATO

LANAO

KIDS

SQUARE

ASKET

green / riot red - glossy

SUPER FIT
by GHOST



NIRVANA TRAIL UNIVERSAL

| | | |
|--|------------------------------|---|
| NIRVANA AL | SRAM PG-1210 11-50 | WTB Wafel |
| Rock Shox Recon Silver RL 140mm | Shimano BR-MT410 180 mm Disc | Schwalbe Nobby Nic Super Trail Addix Soft 2.4 // Schwalbe Nobby Nic Super Ground Addix Speed Grip 2.4 |
| Ground Fiftyone Dia. 31.8 mm | Eightpins hydraulic 34.9 mm | WTB ST i25 // WTB ST i25 |
| Ground Fiftyone Race Dia. 31.8 mm 0/700 mm (XS/S) 20/720 mm (M) 27/740 mm (L) 40/760 mm (XL) | WTB Volt | Shimano HB-MT400-B 15x110 mm |
| SRAM GX Eagle 12-S | Strummer Semi-integrated | Shimano FH-MT410-B 12x148 mm |
| SRAM SX Eagle | SRAM Powerspline 118/73 | |
| Truvativ Stylo 6K 32T | FRHG0025 | |

| GRÖSSE | ARTIKELNUMMER | LAUFRADGRÖSSE |
|--------|---------------|---------------|
| S | 93NI1030 | 27.5 |
| M | 93NI1031 | 29 |
| L | 93NI1032 | 29 |
| XL | 93NI1033 | 29 |







dark blue pearl / bright blue - glossy



SUPER FIT
by GHOST



NIRVANA TOUR UNIVERSAL

NIRVANA AL

Rock Shox Recon Silver RL
100 mm (XS) 120 mm (S-XL)

Ground Fiftyone Dia. 31.8 mm

Ground Fiftyone Race Dia. 31.8 mm
0/700 mm (XS/S) 20/720 mm (M) 27/740 mm (L) 40/760 mm (XL)

SRAM X01 Eagle 12-S

SRAM SX Eagle

Truvativ Stylo 6K 32T

SRAM PG-1210 11-50

Shimano BR-MT410 180 mm Disc

GND 51 34.9 mm

Selle Italia Adjustable

Strummer Semi-integrated

SRAM Powerspline 118/73

FRHG0025

Production Privee CR35

Schwalbe Nobby Nic Performance 2.35 //
Schwalbe Nobby Nic Performance 2.35

WTB ST i25 //
WTB ST i25

Shimano HB-MT400-B 15x110 mm

Shimano FH-MT410-B 12x148 mm

| GRÖSSE | ARTIKELNUMMER | LAUFRADGRÖSSE |
|--------|---------------|---------------|
| XS | 93NI1022 | 27.5 |
| S | 93NI1023 | 27.5 |
| M | 93NI1024 | 29 |
| L | 93NI1025 | 29 |
| XL | 93NI1026 | 29 |



metallic kaki / warm grey pearl - matt



NIRVANA TOUR ESSENTIAL

| | |
|--|---|
| | NIRVANA AL |
| | SR Suntour Raidon 32 LOR DS 100 mm (XS) 120 mm (S-XL) |
| | Ground Fiftyone Dia. 31.8 mm |
| | Ground Fiftyone Race Dia. 31.8 mm 0/700 mm (XS/S) 20/720 mm (M) 27/740 mm (L) 40/760 mm (XL) |
| | Shimano XT RD-M8100 12-S |
| | Shimano Deore SL-M6100 |
| | Shimano FC-MT511 32T |

| | |
|--|------------------------------|
| | Shimano Deore CS-M6100 10-51 |
| | Tektro HD-M275 180 mm |
| | GND 51 34.9 mm |
| | Selle Italia Adjustable |
| | Strummer Semi-integrated |
| | BSA |
| | FRHG0025 |

| | |
|--|---|
| | Production Privee CR35 |
| | WTB Ranger 2.3 Comp // WTB Ranger 2.3 Comp |
| | Schürmann Yak Disc 25 // Schürmann Yak Disc 25 |
| | Shimano HB-MT400-B 15x110 mm |
| | Shimano FH-MT410-B 12x148 mm |

| GRÖSSE | ARTIKELNUMMER | LAUFRADGRÖSSE |
|--------|---------------|---------------|
| XS | 93NI1015 | 27.5 |
| S | 93NI1016 | 27.5 |
| M | 93NI1017 | 29 |
| L | 93NI1018 | 29 |
| XL | 93NI1019 | 29 |



light grey pearl / dark grey - glossy

SUPER FIT
by GHOST



NIRVANA TOUR

| | |
|--|---|
| | NIRVANA AL |
| | SR Suntour XCR32 100 mm (XS) 120 mm (S-XL) |
| | Ground Fiftyone Dia. 31.8 mm |
| | Ground Fiftyone Race Dia. 31.8 mm 0/700 mm (XS/S) 20/720 mm (M) 27/740 mm (L) 40/760 mm (XL) |
| | SRAM SX Eagle 12-S |
| | SRAM SX Eagle |
| | SRAM SX Eagle 32T |

| | |
|--|--------------------------|
| | SRAM PG-1210 11-50 |
| | Tektro HD-M275 180 mm |
| | GND 51 34.9 mm |
| | Selle Italia Adjustable |
| | Strummer Semi-integrated |
| | Sram Power Spline 118/73 |
| | FRHG0025 |

| | |
|--|---|
| | Production Privee CR35 |
| | WTB Ranger 2.3 Comp // WTB Ranger 2.3 Comp |
| | Schürmann Yak Disc 25 // Schürmann Yak Disc 25 |
| | Shimano HB-MT400-B 15x110 mm |
| | Shimano FH-MT400-B 12x148 mm |

| GRÖSSE | ARTIKELNUMMER | LAUFRADGRÖSSE |
|--------|---------------|---------------|
| XS | 93NI1001 | 27.5 |
| S | 93NI1002 | 27.5 |
| M | 93NI1003 | 29 |
| L | 93NI1004 | 29 |
| XL | 93NI1005 | 29 |



raw alu / chrome - glossy



NIRVANA 4X

NIRVANA 4x

X-Fusion Slant 34 RC 100 mm

Ground Fiftyone Dia. 35 mm

Ground Fiftyone Race Dia. 35 mm 20/780 mm

Shimano Deore FC-M5100 30T

Formula 13T

Shimano BR-MT410 160 mm Disc

JD-SP20T 34.9

Selle Italia X-Base

Acros ZS44/56

BSA

FRHG0025

WTB Wafel

Maxxis DTH 26x2.30 //
Maxxis DTH 26x2.30

WTB ST Light i29 //
WTB ST Light i29

Shimano HB-MT400-B 15x110 mm

Shimano FH-MT400-B 12x148 mm

GRÖSSE ARTIKELNUMMER LAUFRADGRÖSSE

M

93NI1100

26



BIKES



RIOT

LECTOR

NIRVANA

KATO

LANAO

KIDS

SQUARE

ASKET



blue green / monarch orange - matt



SUPER FIT
by GHOST



KATO FS UNIVERSAL

KATO FS AL

Rock Shox Recon Silver RL 130 mm

Rock Shox Deluxe Select R 130 mm

Ground Fiftyone Dia. 31.8 mm

Ground Fiftyone Dia. 31.8 mm
720mm (S) 740mm (M-L) 780mm (XL)

Shimano XT RD-M8100 12-S

Shimano Deore SL-M6100

Shimano FC-MT510 32T

Shimano Deore CS-M6100 10-51

Shimano BR-MT501 180 mm Disc

Limotec Alpha 1 31.6 mm
125 (XS/S) M-XL 150 (M-XL)

Selle Italia X-Base

Strummer Semi-integrated

Shimano BB52 BSA

FRHG0061

MTB Grip

WTB Ranger 2.3 Comp //
WTB Ranger 2.3 Comp

WTB ST i30 //
WTB ST i30

Shimano HB-MT400-B 15x110 mm

Shimano FH-MT410-B 12x148 mm

GRÖSSE ARTIKELNUMMER LAUFRADGRÖSSE

XS 93KA2031

27.5

S 93KA2019

27.5

M 93KA2020

29

L 93KA2021

29

XL 93KA2022

29





black / green bay metallic - matt



SUPER FIT
by GHOST



KATO FS ESSENTIAL

KATO FS AL

SR Suntour XCR34 Air 130 mm

SR Suntour Raidon R 130 mm

Ground Fiftyone Dia. 31.8 mm

Ground Fiftyone Dia. 31.8 mm
720mm (S) 740mm (M-L) 780mm (XL)

SRAM GX Eagle 12-S

SRAM SX Eagle

Truvativ Stylo 6K 32T

SRAM PG-1230 11-50

Shimano BR-MT410 180 mm Disc

Limotec Alpha 1 31.6 mm
125 (XS/S) M-XL 150 (M-XL)

Selle Italia X-Base

Strummer Semi-integrated

SRAM Power Spline 118/73

FRHG0061

MTB Grip

WTB Ranger 2.3 Comp //
WTB Ranger 2.3 Comp

Schürmann Yak Disc 25 //
Schürmann Yak Disc 25

Shimano HB-MT400-B 15x110 mm

Shimano FH-MT410-B 12x148 mm

GRÖSSE ARTIKELNUMMER LAUFRADGRÖSSE

| | | |
|----|----------|------|
| XS | 93KA2029 | 27.5 |
| S | 93KA2013 | 27.5 |
| M | 93KA2014 | 29 |
| L | 93KA2015 | 29 |
| XL | 93KA2016 | 29 |



light grey pearl / riot red - matt

SUPER FIT
by GHOST



KATO FS

KATO FS AL

SR Suntour XCR34 Coil 130 mm

SR Suntour Raidon R 130 mm

Ground Fiftyone Dia. 31.8 mm

Ground Fiftyone Dia. 31.8 mm
720mm (S) 740mm (M-L) 780mm (XL)

SRAM SX Eagle 12-S

SRAM SX Eagle

SRAM SX Eagle 32T

SRAM PG-1210 11-50

Shimano BR-MT200 180 mm Disc

GND 51 31.6 mm

Selle Italia X-Base

Strummer semi-integrated

SRAM Power Spline 118/73

FRHG0061

MTB Grip

WTB Ranger 2.3 Comp //
WTB Ranger 2.3 Comp

Schürmann Yak Disc 25 //
Schürmann Yak Disc 25

Shimano HB-MT400-B 15x110 mm

Shimano FH-MT410-B 12x148 mm

| GRÖSSE | ARTIKELNUMMER | LAUFRADGRÖSSE |
|--------|---------------|---------------|
| XS | 93KA2027 | 27.5 |
| S | 93KA2007 | 27.5 |
| M | 93KA2008 | 29 |
| L | 93KA2009 | 29 |
| XL | 93KA2010 | 29 |





green / black - matt



KATO PRO

KATO AL

Rock Shox Judy TK R 100 mm

Ground Fiftyone Dia. 31.8 mm

Ground Fiftyone Dia. 31.8 mm
Ø/700 mm (XS) Ø/720 mm (S) Ø/740 mm (M-L) Ø/760 (XL)

Shimano Deore RD-M6100 12-S

Shimano Deore SL-M6100

Shimano FC-MT510 32T

Shimano Deore CS-M6100 10-51

Shimano BR-MT200 180 mm Disc

GHOST SP DC1 31.6 mm

Selle Italia X-Base

14106

Shimano BB52 BSA

FRHG0004

MTB Grip

Schwalbe Smart Sam 29x2.25 //
Schwalbe Smart Sam 29x2.25

Rodi Excalibur XC 19 //
Rodi Excalibur XC 19

Shimano HB-TX505 QR 100 mm

Shimano FH-MT401 QR 135 mm

| GRÖSSE | ARTIKELNUMMER | LAUFRADGRÖSSE |
|--------|---------------|---------------|
| S | 93KA1113 | 29 |
| M | 93KA1114 | 29 |
| L | 93KA1115 | 29 |
| XL | 93KA1116 | 29 |



| GRÖSSE | ARTIKELNUMMER | LAUFRADGRÖSSE |
|--------|---------------|---------------|
| XS | 93KA1044 | 27.5 |
| S | 93KA1045 | 27.5 |
| M | 93KA1046 | 27.5 |



light grey pearl / black - matt



KATO PRO

KATO AL

Rock Shox Judy TK R 100 mm

Ground Fiftyone Dia. 31.8 mm

Ground Fiftyone Dia. 31.8 mm
0/700 mm (XS) 0/720 mm (S) 0/740 mm (M-L) 0/760 (XL)

Shimano Deore RD-M6100 12-S

Shimano Deore SL-M6100

Shimano FC-MT510 32T

Shimano Deore CS-M6100 10-51

Shimano BR-MT200 180 mm Disc

GHOSH SP DC1 31.6 mm

Selle Italia X-Base

14106

Shimano BB52 BSA

FRHG0004

MTB Grip

Schwalbe Smart Sam 29x2.25 //
Schwalbe Smart Sam 29x2.25

Rodi Excalibur XC 19 //
Rodi Excalibur XC 19

Shimano HB-TX505 QR 100 mm

Shimano FH-MT401 QR 135 mm

| GRÖSSE | ARTIKELNUMMER | LAUFRADGRÖSSE |
|--------|---------------|---------------|
| S | 93KA1108 | 29 |
| M | 93KA1109 | 29 |
| L | 93KA1110 | 29 |
| XL | 93KA1111 | 29 |



| GRÖSSE | ARTIKELNUMMER | LAUFRADGRÖSSE |
|--------|---------------|---------------|
| XS | 93KA1040 | 27.5 |
| S | 93KA1041 | 27.5 |
| M | 93KA1042 | 27.5 |



light grey / dark orange - matt / glossy



KATO ADVANCED

KATO AL

SR Suntour XCR RL-R AIR 100 mm

Ground Fiftyone Dia. 31.8 mm

Ground Fiftyone Dia. 31.8 mm
0/700 mm (XS) 0/720 mm (S) 0/740 mm (M-L) 0/760 (XL)

Shimano Deore RD-M4120 10-S

Shimano Deore FD-M4100-M

Shimano Deore SL-M4100

Shimano Deore FC-M4100 36-26

Shimano Deore CS-M4100 11-42

Shimano BR-MT200 180 mm Disc

GHOST SP DC1 31.6 mm

Selle Italia X-Base

14106

Shimano BB52 BSA

FRHG0004

MTB Grip

Schwalbe Smart Sam 29x2.25 //
Schwalbe Smart Sam 29x2.25

Rodi Excalibur XC 19 //
Rodi Excalibur XC 19

Shimano HB-TX505 QR 100 mm

Shimano FH-TX505 QR 135 mm

| GRÖSSE | ARTIKELNUMMER | LAUFRADGRÖSSE |
|--------|---------------|---------------|
| S | 93KA1101 | 29 |
| M | 93KA1102 | 29 |
| L | 93KA1103 | 29 |
| XL | 93KA1104 | 29 |



| GRÖSSE | ARTIKELNUMMER | LAUFRADGRÖSSE |
|--------|---------------|---------------|
| XS | 93KA1034 | 27.5 |
| S | 93KA1035 | 27.5 |
| M | 93KA1036 | 27.5 |





KATO ADVANCED

KATO AL

SR Suntour XCR RL-R AIR 100 mm

Ground Fiftyone Dia. 31.8 mm

Ground Fiftyone Dia. 31.8 mm
0/700 mm (XS) 0/720 mm (S) 0/740 mm (M-L) 0/760 (XL)

Shimano Deore RD-M4120 10-S

Shimano Deore FD-M4100-M

Shimano Deore SL-M4100

Shimano Deore FC-M4100 36-26

Shimano Deore CS-M4100 11-42

Shimano BR-MT200 180 mm Disc

GHOST SP DC1 31.6 mm

Selle Italia X-Base

14106

Shimano BB52 BSA

FRHG0004

MTB Grip

Schwalbe Smart Sam 29x2.25 //
Schwalbe Smart Sam 29x2.25

Rodi Excalibur XC 19 //
Rodi Excalibur XC 19

Shimano HB-TX505 QR 100 mm

Shimano FH-TX505 QR 135 mm

| GRÖSSE | ARTIKELNUMMER | LAUFRADGRÖSSE |
|--------|---------------|---------------|
| S | 93KA1096 | 29 |
| M | 93KA1097 | 29 |
| L | 93KA1098 | 29 |
| XL | 93KA1099 | 29 |



| GRÖSSE | ARTIKELNUMMER | LAUFRADGRÖSSE |
|--------|---------------|---------------|
| XS | 93KA1030 | 27.5 |
| S | 93KA1031 | 27.5 |
| M | 93KA1032 | 27.5 |



bluegreen pearl / azur blue metallic - glossy



KATO UNIVERSAL

| | | |
|--|---------------------------|---|
| KATO AL | Shimano FC-MT101 44-32-22 | FRHG0004 |
| Rock Shox Judy TK R 100 mm | Shimano CS-HG-200-9 11-36 | MTB Grip |
| Ground Fiftyone Dia. 31.8 mm | Tektro HD-M275 180 mm | Mitas Ocelot 29x2.35 // Mitas Ocelot 29x2.35 |
| Ground Fiftyone Dia. 31.8 mm Ø/700 mm (XS) Ø/720 mm (S) Ø/740 mm (M-L) Ø/760 (XL) | GHOST SP DC1 31.6 mm | Rodi Excalibur XC 19 // Rodi Excalibur XC 19 |
| Shimano Alivio RD-M3100 9-S | Selle Italia X-Base | Shimano HB-TX505 QR 100 mm |
| Shimano Altus FD-M370 | 14106 | Shimano FH-TX505 QR 135 mm |
| Shimano Alivio SL-M3100 | BB-Thun | |

| GRÖSSE | ARTIKELNUMMER | LAUFRADGRÖSSE |
|--------|---------------|---------------|
| S | 93KA1089 | 29 |
| M | 93KA1090 | 29 |
| L | 93KA1091 | 29 |
| XL | 93KA1092 | 29 |



| GRÖSSE | ARTIKELNUMMER | LAUFRADGRÖSSE |
|--------|---------------|---------------|
| XS | 93KA1024 | 27.5 |
| S | 93KA1025 | 27.5 |
| M | 93KA1026 | 27.5 |



black / bright blue - glossy



KATO UNIVERSAL

KATO AL

Rock Shox Judy TK R 100 mm

Ground Fiftyone Dia. 31.8 mm

Ground Fiftyone Dia. 31.8 mm
0/700 mm (XS) 0/720 mm (S) 0/740 mm (M-L) 0/760 (XL)

Shimano Alivio RD-M3100 9-S

Shimano Altus FD-M370

Shimano Alivio SL-M3100

Shimano FC-MT101 44-32-22

Shimano CS-HG-200-9 11-36

Tektro HD-M275 180 mm

GHOST SP DC1 31.6 mm

Selle Italia X-Base

14106

BB-Thun

FRHG0004

MTB Grip

Mitas Ocelot 29x2.35 //
Mitas Ocelot 29x2.35

Rodi Excalibur XC 19 //
Rodi Excalibur XC 19

Shimano HB-TX505 QR 100 mm

Shimano FH-TX505 QR 135 mm

| GRÖSSE | ARTIKELNUMMER | LAUFRADGRÖSSE |
|--------|---------------|---------------|
| S | 93KA1084 | 29 |
| M | 93KA1085 | 29 |
| L | 93KA1086 | 29 |
| XL | 93KA1087 | 29 |



| GRÖSSE | ARTIKELNUMMER | LAUFRADGRÖSSE |
|--------|---------------|---------------|
| XS | 93KA1020 | 27.5 |
| S | 93KA1021 | 27.5 |
| M | 93KA1022 | 27.5 |



light grey / black - matt



KATO ESSENTIAL

- KATO AL
- RST Blaze 100 mm
- Ground Fiftyone Dia. 31.8 mm
- Ground Fiftyone Dia. 31.8 mm
Ø/700 mm (XS) Ø/720 mm (S) Ø/740 mm (M-L) Ø/760 (XL)
- Shimano Acera RD-M360 8-S
- Shimano Tourney FD-TY700-TS6
- Shimano Altus SL-M315

- Shimano FC-TY301 42-34-24
- Shimano CS-HG-200-8 12-32
- Tektro HD-M275 180 mm
- GHOST SP DC1 31.6 mm
- Selle Italia X-Base
- 14106
- BB-Thun

- FRHG0004
- MTB Grip
- Mitas Ocelot 29x2.35 //
Mitas Ocelot 29x2.35
- Rodi Excalibur XC 19 //
Rodi Excalibur XC 19
- Shimano HB-TX505 QR 100 mm
- Shimano FH-TX505 QR 135 mm

| GRÖSSE | ARTIKELNUMMER | LAUFRADGRÖSSE |
|--------|---------------|---------------|
| S | 93KA1072 | 29 |
| M | 93KA1073 | 29 |
| L | 93KA1074 | 29 |
| XL | 93KA1075 | 29 |



| GRÖSSE | ARTIKELNUMMER | LAUFRADGRÖSSE |
|--------|---------------|---------------|
| XS | 93KA1010 | 27.5 |
| S | 93KA1011 | 27.5 |
| M | 93KA1012 | 27.5 |



baby blue pearl / dark orange - glossy



KATO ESSENTIAL

KATO AL

RST Blaze 100 mm

Ground Fiftyone Dia. 31.8 mm

Ground Fiftyone Dia. 31.8 mm
Ø/700 mm (XS) Ø/720 mm (S) Ø/740 mm (M-L) Ø/760 (XL)

Shimano Acera RD-M360 8-S

Shimano Tourney FD-TY700-TS6

Shimano Altus SL-M315

Shimano FC-TY301 42-34-24

Shimano CS-HG-200-8 12-32

Tektro HD-M275 180 mm

GHOST SP DC1 31.6 mm

Selle Italia X-Base

14106

BB-Thun

FRHG0004

MTB Grip

Mitas Ocelot 29x2.35 //
Mitas Ocelot 29x2.35

Rodi Excalibur XC 19 //
Rodi Excalibur XC 19

Shimano HB-TX505 QR 100 mm

Shimano FH-TX505 QR 135 mm

| GRÖSSE | ARTIKELNUMMER | LAUFRADGRÖSSE |
|--------|---------------|---------------|
| S | 93KA1077 | 29 |
| M | 93KA1078 | 29 |
| L | 93KA1079 | 29 |
| XL | 93KA1080 | 29 |



| GRÖSSE | ARTIKELNUMMER | LAUFRADGRÖSSE |
|--------|---------------|---------------|
| XS | 93KA1014 | 27.5 |
| S | 93KA1015 | 27.5 |
| M | 93KA1016 | 27.5 |



black / riot red - glossy



KATO

- KATO AL
- SR Suntour XCE28 DS 100 mm
- Ground Fiftyone Dia. 31.8 mm
- Ground Fiftyone Dia. 31.8 mm
Ø/700 mm (XS) Ø/720 mm (S) Ø/740 mm (M-L) Ø/760 (XL)
- Shimano Tourney RD-TY300 7-S
- Shimano Tourney FD-TY300
- Shimano ST-EF505

- Shimano FC-TY301 42-34-24
- Shimano CS-HG-200-7 12-32
- Shimano BR-MT200 160 mm Disc
- GHOST SP DC1 31.6 mm
- Selle Italia X-Base
- 14106
- BB-Thun

- FRHG0004
- MTB Grip
- Mitas Ocelot 29x2.10 //
Mitas Ocelot 29x2.10
- Schürmann Yak Disc 25 //
Schürmann Yak Disc 25
- Shimano HB-TX505 QR 100 mm
- Shimano FH-TX505 QR 135 mm

| GRÖSSE | ARTIKELNUMMER | LAUFRADGRÖSSE |
|--------|---------------|---------------|
| S | 93KA1060 | 29 |
| M | 93KA1061 | 29 |
| L | 93KA1062 | 29 |
| XL | 93KA1063 | 29 |



| GRÖSSE | ARTIKELNUMMER | LAUFRADGRÖSSE |
|--------|---------------|---------------|
| XS | 93KA1000 | 27.5 |
| S | 93KA1001 | 27.5 |
| M | 93KA1002 | 27.5 |



light mint pearl / black - matt



KATO

- KATO AL
- SR Suntour XCE28 DS 100 mm
- Ground Fiftyone Dia. 31.8 mm
- Ground Fiftyone Dia. 31.8 mm
Ø/700 mm (XS) Ø/720 mm (S) Ø/740 mm (M-L) Ø/760 (XL)
- Shimano Tourney RD-TY300 7-S
- Shimano Tourney FD-TY300
- Shimano ST-EF505

- Shimano FC-TY301 42-34-24
- Shimano CS-HG-200-7 12-32
- Shimano BR-MT200 160 mm Disc
- GHOST SP DC1 31.6 mm
- Selle Italia X-Base
- 14106
- BB-Thun

- FRHG0004
- MTB Grip
- Mitas Ocelot 29x2.10 //
Mitas Ocelot 29x2.10
- Schürmann Yak Disc 25 //
Schürmann Yak Disc 25
- Shimano HB-TX505 QR 100 mm
- Shimano FH-TX505 QR 135 mm

| GRÖSSE | ARTIKELNUMMER | LAUFRADGRÖSSE |
|--------|---------------|---------------|
| S | 93KA1065 | 29 |
| M | 93KA1066 | 29 |
| L | 93KA1067 | 29 |
| XL | 93KA1068 | 29 |



| GRÖSSE | ARTIKELNUMMER | LAUFRADGRÖSSE |
|--------|---------------|---------------|
| XS | 93KA1004 | 27.5 |
| S | 93KA1005 | 27.5 |
| M | 93KA1006 | 27.5 |



black / bright blue - matt



KATO EQ

| |
|--|
| 🔗 KATO AL |
| 🏠 RST Blaze 100 mm |
| 🔗 Ground Fiftyone Dia. 31.8 mm |
| 📏 Ground Fiftyone Dia. 31.8 mm 0/700 mm (XS) 0/720 mm (S) 0/740 mm (M-L) 0/760 (XL) |
| 🔗 Shimano Acera RD-M360 8-S |
| 🔗 Shimano Tourney FD-TY700-TS6 |
| ⚙️ Shimano Altus SL-M315 |
| 🔗 Shimano FC-TY301 42-34-24 |

| |
|-----------------------------|
| 🌀 Shimano CS-HG-200-8 12-32 |
| 🌀 Tektro HD-M275 180 mm |
| 🔗 GHOST SP DC1 31.6 mm |
| 🔗 Selle Italia X-Base |
| 🌀 14106 |
| 🔗 BB-Thun |
| 🔗 FRHG0004 |
| 🔗 MTB Grip |

| |
|---|
| 🌀 Mitas Ocelot 29x2.35 // Mitas Ocelot 29x2.35 |
| 🔗 Schürmann Yak Disc 25 // Schürmann Yak Disc 25 |
| 🔗 Shimano HB-TX505 QR 100 mm |
| 🔗 Shimano FH-TX505 QR 135 mm |
| 🔗 SKS Velotexx 65 |
| 🔗 Büchel Akku Sport |
| 🔗 Büchel Tivoli |

| GRÖSSE | ARTIKELNUMMER | LAUFRADGRÖSSE |
|--------|---------------|---------------|
| S | 93KA1120 | 29 |
| M | 93KA1121 | 29 |
| L | 93KA1122 | 29 |
| XL | 93KA1123 | 29 |



| GRÖSSE | ARTIKELNUMMER | LAUFRADGRÖSSE |
|--------|---------------|---------------|
| XS | 93KA1050 | 27.5 |
| S | 93KA1051 | 27.5 |
| M | 93KA1052 | 27.5 |



metallic kaki / black - matt



KATO EQ

KATO AL

RST Blaze 100 mm

Ground Fiftyone Dia. 31.8 mm

Ground Fiftyone Dia. 31.8 mm
Ø/700 mm (XS) Ø/720 mm (S) Ø/740 mm (M-L) Ø/760 (XL)

Shimano Acera RD-M360 8-S

Shimano Tourney FD-TY700-TS6

Shimano Altus SL-M315

Shimano FC-TY301 42-34-24

Shimano CS-HG-200-8 12-32

Tektro HD-M275 180 mm

GHOST SP DC1 31.6 mm

Selle Italia X-Base

14106

BB-Thun

FRHG0004

MTB Grip

Mitas Ocelot 29x2.35 //
Mitas Ocelot 29x2.35

Schürmann Yak Disc 25 //
Schürmann Yak Disc 25

Shimano HB-TX505 QR 100 mm

Shimano FH-TX505 QR 135 mm

SKS Velotexx 65

Büchel Akku Sport

Büchel Tivoli

| GRÖSSE | ARTIKELNUMMER | LAUFRADGRÖSSE |
|--------|---------------|---------------|
| S | 93KA1125 | 29 |
| M | 93KA1126 | 29 |
| L | 93KA1127 | 29 |
| XL | 93KA1128 | 29 |



| GRÖSSE | ARTIKELNUMMER | LAUFRADGRÖSSE |
|--------|---------------|---------------|
| XS | 93KA1054 | 27.5 |
| S | 93KA1055 | 27.5 |
| M | 93KA1056 | 27.5 |



BIKES



RIOT

LECTOR

NIRVANA

KATO

LANAO

KIDS

SQUARE

ASKET

beige metallic / dark blue pearl - matt



LANA0 PRO

LANA0 AL

Rock Shox Judy TK R 100 mm

Ground Fiftyone Dia. 31.8 mm

Ground Fiftyone Dia. 31.8 mm
0/700 mm (XS) 0/720 mm (S) 0/740 mm (M)

Shimano Deore RD-M6100 12-S

Shimano Deore SL-M6100

Shimano FC-MT510 32T

Shimano Deore CS-M6100 10-51

Shimano BR-MT200 180 mm Disc

GHOST SP DC1 31.6 mm

Selle Italia X-Base

14106

Shimano BB52 BSA

FRHG0004

MTB Grip

Schwalbe Smart Sam 27.5x2.25 //
Schwalbe Smart Sam 27.5x2.25

Rodi Excalibur XC 19 //
Rodi Excalibur XC 19

Shimano HB-TX505 QR 100 mm

Shimano FH-MT401 QR 135 mm

| GRÖSSE | ARTIKELNUMMER | LAUFRADGRÖSSE |
|--------|---------------|---------------|
| XS | 93LA1024 | 27.5 |
| S | 93LA1025 | 27.5 |
| M | 93LA1026 | 27.5 |



black / pearl purple - matt



LANAO ADVANCED

| | | |
|---|------------------------------|--|
| LANAO AL | Shimano Deore FC-M4100 36-26 | FRHG0004 |
| SR Suntour XCR RL-R AIR 100 mm | Shimano Deore CS-M4100 11-42 | MTB Grip |
| Ground Fiftyone Dia. 31.8 mm | Shimano BR-MT200 180 mm Disc | Schwalbe Smart Sam 27.5x2.25 // Schwalbe Smart Sam 27.5x2.25 |
| Ground Fiftyone Dia. 31.8 mm 0/700 mm (XS) 0/720 mm (S) 0/740 mm (M) | GHOST SP DC1 31.6 mm | Rodi Excalibur XC 19 // Rodi Excalibur XC 19 |
| Shimano Deore RD-M4120 10-S | Selle Italia X-Base | Shimano HB-TX505 QR 100 mm |
| Shimano Deore FD-M4100-M | 14106 | Shimano FH-TX505 QR 135 mm |
| Shimano Deore SL-M6000 | Shimano BB52 BSA | |

| GRÖSSE | ARTIKELNUMMER | LAUFRADGRÖSSE |
|--------|---------------|---------------|
| XS | 93LA1018 | |
| S | 93LA1019 | |
| M | 93LA1020 | |



light mint pearl / azur blue metallic - matt



LANAO UNIVERSAL

| | | |
|---|---------------------------|--|
| LANAo AL | Shimano FC-MT101 44-32-22 | FRHG0004 |
| Rock Shox Judy TK R 100 mm | Shimano CS-HG-200-9 11-36 | MTB Grip |
| Ground Fiftyone Dia. 31.8 mm | Tektro HD-M275 180 mm | Mitas Ocelot 27x2.35 // Mitas Ocelot 27x2.35 |
| Ground Fiftyone Dia. 31.8 mm 0/700 mm (XS) 0/720 mm (S) 0/740 mm (M) | GHOST SP DC1 31.6 mm | Rodi Excalibur XC 19 // Rodi Excalibur XC 19 |
| Shimano Alivio RD-M3100 9-S | Selle Italia X-Base | Shimano HB-TX505 QR 100 mm |
| Shimano Altus FD-M370 | 14106 | Shimano FH-TX505 QR 135 mm |
| Shimano Alivio SL-M3100 | BB-Thun | |

| GRÖSSE | ARTIKELNUMMER | LAUFRADGRÖSSE |
|--------|---------------|---------------|
| XS | 93LA1012 | 27.5 |
| S | 93LA1013 | 27.5 |
| M | 93LA1014 | 27.5 |





pearl white / green bay metallic - glossy / matt



LANAO ESSENTIAL

LANAO AL

RST Blaze 100 mm

Ground Fiftyone Dia. 31.8 mm

Ground Fiftyone Dia. 31.8 mm
0/700 mm (XS) 0/720 mm (S) 0/740 mm (M)

Shimano Acera RD-M360 8-S

Shimano Tourney FD-TY700-TS6

Shimano Altus SL-M315

Shimano FC-TY301 42-34-24

Shimano CS-HG-200-8 12-32

Tektro HD-M275 180 mm

GHOST SP DC1 31.6 mm

Selle Italia X-Base

14106

BB-Thun

FRHG0004

MTB Grip

Mitas Ocelot 27x2.35 //
Mitas Ocelot 27x2.35

Rodi Excalibur XC 19 //
Rodi Excalibur XC 19

Shimano HB-TX505 QR 100 mm

Shimano FH-TX505 QR 135 mm

| GRÖSSE | ARTIKELNUMMER | LAUFRADGRÖSSE |
|--------|---------------|---------------|
| XS | 93LA1006 | |
| S | 93LA1007 | |
| M | 93LA1008 | |



light mint pearl / purple pearl - glossy



LANAO

| | | |
|---|------------------------------|---|
| LANAO AL | Shimano FC-TY301 42-34-24 | FRHG0004 |
| SR Suntour XCE28 DS 100 mm | Shimano CS-HG-200-7 12-32 | MTB Grip |
| Ground Fiftyone Dia. 31.8 mm | Shimano BR-MT200 160 mm Disc | Mitas Ocelot 27x2.10 // Mitas Ocelot 27x2.10 |
| Ground Fiftyone Dia. 31.8 mm 0/700 mm (XS) 0/720 mm (S) 0/740 mm (M) | GHOST SP DC1 31.6 mm | Schürmann Yak Disc 25 // Schürmann Yak Disc 25 |
| Shimano Tourney RD-TY300 7-S | Selle Italia X-Base | Shimano HB-TX505 QR 100 mm |
| Shimano Tourney FD-TY300 | 14106 | Shimano FH-TX505 QR 135 mm |
| Shimano ST-EF505 | BB-Thun | |

| GRÖSSE | ARTIKELNUMMER | LAUFRADGRÖSSE |
|--------|---------------|---------------|
| XS | 93LA1000 | |
| S | 93LA1001 | |
| M | 93LA1002 | |







deep red pearl / purple pearl - glossy



LANAQ EQ

LANAQ AL

RST Blaze 100 mm

Ground Fiftyone Dia. 31.8 mm

Ground Fiftyone Dia. 31.8 mm
0/700 mm (XS) 0/720 mm (S) 0/740 mm (M)

Shimano Acera RD-M360 8-S

Shimano Altus SL-M315

Shimano FC-TY301 42-34-24

Shimano CS-HG-200-8 12-32

Tektro HD-M275 180 mm

GHOST SP DC1 31.6 mm

Selle Italia X-Base

14106

BB-Thun

FRHG0004

MTB Grip

Mitas Ocelot 27x2.35 //
Mitas Ocelot 27x2.35

Schürmann Yak Disc 25 //
Schürmann Yak Disc 25

Shimano HB-TX505 QR 100 mm

Shimano FH-MT401 QR 135 mm

SKS Veloflexx 65

Büchel Akku Sport

Büchel Tivoli

| GRÖSSE | ARTIKELNUMMER | LAUFRADGRÖSSE |
|--------|---------------|---------------|
| XS | 93LA1030 | 27.5 |
| S | 93LA1031 | 27.5 |
| M | 93LA1032 | 27.5 |





poseidon blue pearl / green - matt



LANAQ EQ

LANAQ AL

RST Blaze 100 mm

Ground Fiftyone Dia. 31.8 mm

Ground Fiftyone Dia. 31.8 mm
0/700 mm (XS) 0/720 mm (S) 0/740 mm (M)

Shimano Acera RD-M360 8-S

Shimano Altus SL-M315

Shimano FC-TY301 42-34-24

Shimano CS-HG-200-8 12-32

Tektro HD-M275 180 mm

GHOST SP DC1 31.6 mm

Selle Italia X-Base

14106

BB-Thun

FRHG0004

MTB Grip

Mitas Ocelot 27x2.35 //
Mitas Ocelot 27x2.35

Schürmann Yak Disc 25 //
Schürmann Yak Disc 25

Shimano HB-TX505 QR 100 mm

Shimano FH-MT401 QR 135 mm

SKS Veloflexx 65

Büchel Akku Sport

Büchel Tivoli

| GRÖSSE | ARTIKELNUMMER | LAUFRADGRÖSSE |
|--------|---------------|---------------|
| XS | 93LA1034 | 27.5 |
| S | 93LA1035 | 27.5 |
| M | 93LA1036 | 27.5 |



BIKES



RIOT

LECTOR

NIRVANA

KATO

LANAO

KIDS

ROAD RAGE

SQUARE

grey purple / black matt

SUPER FIT
by GHOST



RIOT YOUTH PRO

RIOT Youth Pro

SR Suntour XCR34 Air 130mm

SR Suntour Raidon R 130 mm

Ground Fiftyone Dia. 31.8 mm

Ground Fiftyone Dia. 31.8 mm Ø/700 mm

SRAM GX Eagle 12-S

SRAM SX Eagle

Truvativ Stylo 6K 32T

SRAM PG-1230 11-50

Shimano BR-MT410 180 mm Disc

Limotec Alpha 31.6 mm Travel 125mm

Selle Italia X-Base

Strummer semi-integrated

SRAM Power Spline 118/73

FRHG0061

MTB Grip

WTB Ranger 2.3 Comp //
WTB Ranger 2.3 Comp

WTB ST i30 //
WTB ST i30

Shimano HB-MT400-B 15x110 mm

Shimano FH-MT410-B 12x148 mm

GRÖSSE ARTIKELNUMMER LAUFRADGRÖSSE

XS

93KA2025

27.5





bright blue / black - glossy



KATO YOUTH

KATO YOUTH AL

SR Suntour XCE28 DS 100 mm

Ground Fiftyone Dia. 31.8 mm

Ground Fiftyone Dia. 31.8 mm 700/0

Shimano Tourney RD-TY300 7-S

Shimano Tourney FD-TY300

Shimano ST-EF505

Shimano FC-TY301 42-34-24

Shimano CS-HG-200-7 12-32

Shimano BR-MT200 160 mm Disc

Ghost 31.6 mm

Selle Italia X-Base

Strummer semi-integrated

Shimano BB-UN101

FRHG0004

MTB Grip

Mitas Ocelot 2.10
Mitas Ocelot 2.10

Schürmann Yak Disc 25
Schürmann Yak Disc 25

Shimano HB-TX505 QR 100 mm

Shimano FH-TX505 QR 135 mm

GRÖSSE ARTIKELNUMMER LAUFRADGRÖSSE

XXS

31KA1200

27.5



bright blue / black - glossy



KATO YOUTH EQ

| |
|--------------------------------------|
| 🔗 KATO YOUTH AL |
| 🏠 SR Suntour XCE28 DS 100 mm |
| 🔗 Ground Fiftyone Dia. 31.8 mm |
| 🔗 Ground Fiftyone Dia. 31.8 mm 700/0 |
| 🔗 Shimano Acera RD-M3020 8-S |
| 🔗 Shimano Tourney FD-TY700-TS6 |
| 🔗 Shimano SL-M315 |
| 🔗 Shimano FC-TY301 42-34-24 |

| |
|------------------------------|
| 🔗 Shimano CS-HG-200-8 12-32 |
| 🔗 Tektro HD-M275 180 mm Disc |
| 🔗 Ghost 31.6 mm |
| 🔗 Selle Italia X-Base |
| 🔗 Strummer semi-integrated |
| 🔗 Shimano BB-UN101 |
| 🔗 FRHG0004 |
| 🔗 MTB Grip |

| |
|--|
| 🔗 Mitas Ocelot 2.10 Mitas Ocelot 2.10 |
| 🔗 Schürmann Yak Disc 25 Schürmann Yak Disc 25 |
| 🔗 XLC Carrier |
| 🔗 XLC Fender |
| 🔗 Büchel Akku Sport |
| 🔗 Büchel Tivolo |

GRÖSSE ARTIKELNUMMER LAUFRADGRÖSSE

XXS

31KA1203

27.5





pearl white crystal / blue green - glossy



LANAO YOUTH

LANAo YOUTH AL

SR Suntour XCE28 DS 100 mm

Ground Fiftyone Dia. 31.8 mm

Ground Fiftyone Dia. 31.8 mm 700/0

Shimano Tourney RD-TY300 7-S

Shimano Tourney FD-TY300

Shimano ST-EF505

Shimano FC-TY301 42-34-24

Shimano CS-HG-200-7 12-32

Shimano BR-MT200 160 mm Disc

Ghost 31.6 mm

Selle Italia X-Base

Strummer semi-integrated

Shimano BB-UN101

FRHG0004

MTB Grip

Mitas Ocelot 2.10
Mitas Ocelot 2.10

Schürmann Yak Disc 25
Schürmann Yak Disc 25

Shimano HB-TX505 QR 100 mm

Shimano FH-TX505 QR 135 mm

GRÖSSE ARTIKELNUMMER LAUFRADGRÖSSE

XXS

31LA1035



pearl white crystal / blue green - glossy



LANAO YOUTH EQ

| |
|------------------------------------|
| LANAO YOUTH AL |
| SR Suntour XCE28 DS 100 mm |
| Ground Fiftyone Dia. 31.8 mm |
| Ground Fiftyone Dia. 31.8 mm 700/0 |
| Shimano Acera RD-M3020 8-S |
| Shimano Tourney FD-TY700-TS6 |
| Shimano SL-M315 |
| Shimano FC-TY301 42-34-24 |

| |
|----------------------------|
| Shimano CS-HG-200-8 12-32 |
| Tektro HD-M275 180 mm Disc |
| Ghost 31.6 mm |
| Selle Italia X-Base |
| Strummer semi-integrated |
| Shimano BB-UN101 |
| FRHG0004 |
| MTB Grip |

| |
|--|
| Mitas Ocelot 2.10 Mitas Ocelot 2.10 |
| Schürmann Yak Disc 25 Schürmann Yak Disc 25 |
| XLC Carrier |
| XLC Fender |
| Büchel Akku Sport |
| Büchel Tivolo |

GRÖSSE ARTIKELNUMMER LAUFRADGRÖSSE

XXS

31LA1038





pearl white / bright blue - glossy



SUPER FIT
by GHOST



KATO 24 FULL PARTY

KATO Kid AL

SR Suntour XCR Air LO 80 mm

GHOST 28.6 mm

GHOST Junior 560 mm 25 mm Rise

Shimano Deore RD-M5100 11-S

Shimano Deore SL-M5100

Samox 30T

Shimano Deore CS-M5100 11-42

Tektro HD-M276 Hydraulic Disc

GHOST SP DC1 27.2 mm

DDK 922

FSA

Velo VLG 1979-D

Schwalbe Smart Sam 2.35 //
Schwalbe Smart Sam 2.35

Shining DB-X30 //
Shining DB-X30

KT-TC7F QR

KT-TC7R QR

FRHG0064

GRÖSSE ARTIKELNUMMER LAUFRADGRÖSSE

24

93KA1306

24



silver chrom / dark silver chrom - glossy



KATO 24 FULL PARTY

| | | |
|--------------------------------|-------------------------------|--|
| KATO Kid AL | Samox 30T | Velo VL6 1979-D |
| SR Suntour XCR Air LO 80 mm | Shimano Deore CS-M5100 11-42 | Schwalbe Smart Sam 2.35 // Schwalbe Smart Sam 2.35 |
| GHOST 28.6 mm | Tektro HD-M276 Hydraulic Disc | Shining DB-X30 // Shining DB-X30 |
| GHOST Junior 560 mm 25 mm Rise | GHOST SP DC1 27.2 mm | KT-TC7F QR |
| Shimano Deore RD-M5100 11-S | DDK 922 | KT-TC7R QR |
| Shimano Deore SL-M5100 | FSA | FRHG0064 |

GRÖSSE ARTIKELNUMMER LAUFRADGRÖSSE

24

93KA1305

24



rainbow silver / riot red - glossy



SUPER FIT
by GHOST



KATO 24 PRO

KATO Kid AL

RST Capa T 50 mm

GHOST AS-GH2 31.8 mm

GHOST Junior 560 mm 25 mm Rise

Shimano Deore RD-M6000 10-S

Shimano Deore SL-M4100

Samox 28T

Shimano Deore CS-M4100 11-42

Tektro HD-M276 Hydraulic Disc

GHOST SP DC1 27.2 mm

DDK 922

FSA

Velo VLG 1979-D

Schwalbe Smart Sam 2.35 //
Schwalbe Smart Sam 2.35

Shining DB-X30 //
Shining DB-X30

KT-T04F OR

KT-MR5R OR

FRHG0064

GRÖSSE ARTIKELNUMMER LAUFRADGRÖSSE

24

93KA1300

24





candy lime green / black - glossy



SUPER FIT
by GHOST



KATO 24 PRO

KATO Kid AL

RST Capa T 50 mm

GHOST AS-GH2 31.8 mm

GHOST Junior 560 mm 25 mm Rise

Shimano Deore RD-M6000 10-S

Shimano Deore SL-M4100

Samox 28T

Shimano Deore CS-M4100 11-42

Tektro HD-M276 Hydraulic Disc

GHOST SP DC1 27.2 mm

DDK 922

FSA

Velo VLG 1979-D

Schwalbe Smart Sam 2.35 //
Schwalbe Smart Sam 2.35

Shining DB-X30 //
Shining DB-X30

KT-T04F QR

KT-MR5R QR

FRHG0064

GRÖSSE ARTIKELNUMMER LAUFRADGRÖSSE

24

93KA1301

24



rainbow silver / riot red - glossy



SUPER FIT
by GHOST



KATO 24 PRO EQ

KATO Kid AL

Ghost Rigid

GHOST TDS-C614N

GHOST Junior 560 mm 25 mm Rise

Shimano Deore RD-M6000 10-S

Shimano Deore SL-M4100

Samox 28T

Shimano Deore CS-M4100 11-42

Tektro HD-M276 Hydraulic Disc

GHOST SP DC1 27.2 mm

DDK 922

FSA

Velo VLG 1979-D

Schwalbe Smart Sam 2.35 //
Schwalbe Smart Sam 2.35

Shining DB-X30 //
Shining DB-X30

KT-T04F QR

KT-MR5R QR

Unikey 24" Carrier

Sunnywheel SW-B25FR

Nuvo Adjustable 20-28"

Spanninga X&O 25

Spanninga Solo XB

FRHG0064

GRÖSSE ARTIKELNUMMER LAUFRADGRÖSSE

24

93KA1303

24





Dirty blue / metallic lime - glossy



SUPER FIT
by GHOST



KATO 20 FULL PARTY

| |
|--------------------------------|
| KATO Kid AL |
| GHOST Suspension |
| GHOST 28.6 mm |
| GHOST Junior 540 mm 25 mm Rise |
| Shimano Deore RD-M6000 10-S |
| Shimano Deore SL-M4100 |

| |
|-------------------------------|
| Samox 28T |
| Shimano Deore CS-M4100 11-42 |
| Tektro HD-M276 Hydraulic Disc |
| GHOST SP DC1 27.2 mm |
| GHOST VL 5062 |
| FSA |

| |
|--|
| Velo VLG 1979-D |
| Schwalbe Smart Sam 2.35 // Schwalbe Smart Sam 2.35 |
| Shining DB-X30 // Shining DB-X30 |
| KT-T04F QR |
| KT-MR5R QR |
| FRHG0064 |

GRÖSSE ARTIKELNUMMER LAUFRADGRÖSSE

20

93KA1203

20





pearl white / bright blue - glossy



SUPER FIT
by GHOST



KATO 20 FULL PARTY

KATO Kid AL

GHOST Suspension

GHOST 28.6 mm

GHOST Junior 540 mm 25 mm Rise

Shimano Deore RD-M6000 10-S

Shimano Deore SL-M4100

Samox 28T

Shimano Deore CS-M4100 11-42

Tektro HD-M276 Hydraulic Disc

GHOST SP DC1 27.2 mm

GHOST VL 5062

FSA

Velo VLG 1979-D

Schwalbe Smart Sam 2.35 //
Schwalbe Smart Sam 2.35

Shining DB-X30 //
Shining DB-X30

KT-T04F OR

KT-MR5R OR

FRHG0064

GRÖSSE ARTIKELNUMMER LAUFRADGRÖSSE

20

93KA1204

20



Black / Ocean candy - glossy

SUPER FIT
by *GHOST*



KATO 20 PRO

KATO Kid AL

GHOST Rigid

GHOST AS-601 25.4 mm

GHOST Junior 540 mm 25 mm Rise

Shimano Acera RD-M360 8-S

Shimano Altus SL-M315

Samox 28T

Shimano CS-HG31 11-34

Tektro 837 AL V-Brake

GHOST SP DC1 27.2 mm

GHOST VL 5062

FSA

Velo VL6 1979-D

Schwalbe Smart Sam 2.35 //
Schwalbe Smart Sam 2.35

Shining MT-46 //
Shining MT-46

KT-A15F OR

KT-AZER OR

FRHG0064

GRÖSSE ARTIKELNUMMER LAUFRADGRÖSSE

20

93KA1200

20





green / monarch orange - glossy



SUPER FIT
by GHOST



KATO 20 PRO

KATO Kid AL

GHOST Rigid

GHOST AS-601 25.4 mm

GHOST Junior 540 mm 25 mm Rise

Shimano Acera RD-M360 8-S

Shimano Altus SL-M315

Samox 28T

Shimano CS-HG31 11-34

Tektro 837 AL V-Brake

GHOST SP DC1 27.2 mm

GHOST VL 5062

FSA

Velo VLG 1979-D

Schwalbe Smart Sam 2.35 //
Schwalbe Smart Sam 2.35

Shining MT-46 //
Shining MT-46

KT-A15F OR

KT-AZER OR

FRHG0064

GRÖSSE ARTIKELNUMMER LAUFRADGRÖSSE

20

93KA1201

20



black / fogbow purple - glossy

SUPER FIT
by **GHOST**



LANAo 24 FULL PARTY

| |
|--------------------------------|
| LANAo Kid AL |
| SR Suntour XCR Air LO 80 mm |
| GHOST 28.6 mm |
| GHOST Junior 560 mm 25 mm Rise |
| Shimano Deore RD-M5100 11-S |
| Shimano Deore SL-M5100 |

| |
|-------------------------------|
| Samox 30T |
| Shimano Deore CS-M5100 11-42 |
| Tektro HD-M276 Hydraulic Disc |
| GHOST SP DC1 27.2 mm |
| DDK 922 |
| FSA |

| |
|---|
| Velo VL6 1979-D |
| Schwalbe Smart Sam 2.35 // Schwalbe Smart Sam 2.35 |
| Shining DB-X30 // Shining DB-X30 |
| KT-TC7F QR |
| KT-TC7R QR |
| FRHG0064 |

GRÖSSE ARTIKELNUMMER LAUFRADGRÖSSE

24

93LA1305

24





sid chrom / candy magenta - glossy



SUPER FIT
by GHOST



LANAO 24 FULL PARTY

LANAO Kid AL

SR Suntour XCR Air LO 80 mm

GHOST 28.6 mm

GHOST Junior 560 mm 25 mm Rise

Shimano Deore RD-M5100 11-S

Shimano Deore SL-M5100

Samox 30T

Shimano Deore CS-M5100 11-42

Tektro HD-M276 Hydraulic Disc

GHOST SP DC1 27.2 mm

DDK 922

FSA

Velo VLG 1979-D

Schwalbe Smart Sam 2.35 //
Schwalbe Smart Sam 2.35

Shining DB-X30 //
Shining DB-X30

KT-TC7F QR

KT-TC7R QR

FRHG0064

GRÖSSE ARTIKELNUMMER LAUFRADGRÖSSE

24

93LA1306

24



baby blue / magenta - glossy

SUPER FIT
by GHOST



LANAO 24 PRO

LANAO Kid AL

RST Capa T 50 mm

GHOST AS-GH2 31.8 mm

GHOST Junior 560 mm 25 mm Rise

Shimano Deore RD-M6000 10-S

Shimano Deore SL-M4100

Samox 28T

Shimano Deore CS-M4100 11-42

Tektro HD-M276 Hydraulic Disc

GHOST SP DC1 27.2 mm

DDK 922

FSA

Velo VLG 1979-D

Schwalbe Smart Sam 2.35 //
Schwalbe Smart Sam 2.35

Shining DB-X30 //
Shining DB-X30

KT-T04F QR

KT-MR5R QR

FRHG0064

GRÖSSE ARTIKELNUMMER LAUFRADGRÖSSE

24

93LA1300

24





dazzling green / pearl white - glossy



SUPER FIT
by GHOST



LANA 24 PRO

LANA Kid AL

RST Capa T 50 mm

GHOST AS-GH2 31.8 mm

GHOST Junior 560 mm 25 mm Rise

Shimano Deore RD-M6000 10-S

Shimano Deore SL-M4100

Samox 28T

Shimano Deore CS-M4100 11-42

Tektro HD-M276 Hydraulic Disc

GHOST SP DC1 27.2 mm

DDK 922

FSA

Velo VLG 1979-D

Schwalbe Smart Sam 2.35 //
Schwalbe Smart Sam 2.35

Shining DB-X30 //
Shining DB-X30

KT-T04F OR

KT-MR5R OR

FRHG0064

GRÖSSE ARTIKELNUMMER LAUFRADGRÖSSE

24

93LA1301

24



dazzling green / pearl white - glossy



SUPER FIT
by GHOST



LANAO 24 PRO EQ

| |
|--------------------------------|
| LANAO Kid AL |
| Ghost Rigid |
| GHOST TDS-C614N |
| GHOST Junior 560 mm 25 mm Rise |
| Shimano Deore RD-M6000 10-S |
| Shimano Deore SL-M4100 |
| Samox 28T |
| Shimano Deore CS-M4100 11-42 |

| |
|--|
| Tektro HD-M276 Hydraulic Disc |
| GHOST SP DC1 27.2 mm |
| DDK 922 |
| FSA |
| Velo VLG 1979-D |
| Schwalbe Smart Sam 2.35 // Schwalbe Smart Sam 2.35 |
| Shining DB-X30 // Shining DB-X30 |
| KT-T04F QR |

| |
|------------------------|
| KT-MR5R QR |
| Unikey 24" Carrier |
| Sunnywheel SW-B25FR |
| Nuvo Adjustable 20-28" |
| Spanninga X&O 25 |
| Spanninga Solo XB |
| FRHG0064 |

GRÖSSE ARTIKELNUMMER LAUFRADGRÖSSE

24

93LA1303

24





metallic black / pink shimmer - glossy



SUPER FIT
by GHOST



LANAo 20 FULL PARTY

LANAo Kid AL

GHOST Suspension

GHOST 28.6 mm

GHOST Junior 540 mm 25 mm Rise

Shimano Deore RD-M6000 10-S

Shimano Deore SL-M4100

Samox 28T

Shimano Deore CS-M4100 11-42

Tektro HD-M276 Hydraulic Disc

GHOST SP DC1 27.2 mm

GHOST VL 5062

FSA

Velo VL6 1979-D

Schwalbe Smart Sam 2.35 //
Schwalbe Smart Sam 2.35

Shining DB-X30 //
Shining DB-X30

KT-T04F QR

KT-MR5R QR

FRHG0064

GRÖSSE ARTIKELNUMMER LAUFRADGRÖSSE

20

93LA1203

20



light mint pearl / fogbow purple - glossy

SUPER FIT
by GHOST



LANAO 20 FULL PARTY

| | | |
|--------------------------------|-------------------------------|--|
| LANAo Kid AL | Samox 28T | Velo VL6 1979-D |
| GHOST Suspension | Shimano Deore CS-M4100 11-42 | Schwalbe Smart Sam 2.35 // Schwalbe Smart Sam 2.35 |
| GHOST 28.6 mm | Tektro HD-M276 Hydraulic Disc | Shining DB-X30 // Shining DB-X30 |
| GHOST Junior 540 mm 25 mm Rise | GHOST SP DC1 27.2 mm | KT-T04F OR |
| Shimano Deore RD-M6000 10-S | GHOST VL 5062 | KT-MR5R QR |
| Shimano Deore SL-M4100 | FSA | FRHG0064 |

GRÖSSE ARTIKELNUMMER LAUFRADGRÖSSE

20

93LA1204

20



green goldlit / light mint - glossy



SUPER FIT
by GHOST



LANAO 20 PRO

LANAO Kid AL

GHOST Rigid

GHOST AS-601 25.4 mm

GHOST Junior 540 mm 25 mm Rise

Shimano Acera RD-M360 8-S

Shimano Altus SL-M315

Samox 28T

Shimano CS-HG31 11-34

Tektro 837 AL V-Brake

GHOST SP DC1 27.2 mm

GHOST VL 5062

FSA

Velo VLG 1979-D

Schwalbe Smart Sam 2.35 //
Schwalbe Smart Sam 2.35

Shining MT-46 //
Shining MT-46

KT-A15F QR

KT-AZER QR

FRHG0064

GRÖSSE ARTIKELNUMMER LAUFRADGRÖSSE

20

93LA1200

20



light mint / pink shimmer - glossy

SUPER FIT
by *GHOST*



LANAO 20 PRO

LANAO Kid AL

GHOST Rigid

GHOST AS-601 25.4 mm

GHOST Junior 540 mm 25 mm Rise

Shimano Acera RD-M360 8-S

Shimano Altus SL-M315

Samox 28T

Shimano CS-HG31 11-34

Tektro 837 AL V-Brake

GHOST SP DC1 27.2 mm

GHOST VL 5062

FSA

Velo VLG 1979-D

Schwalbe Smart Sam 2.35 //
Schwalbe Smart Sam 2.35

Shining MT-46 //
Shining MT-46

KT-A15F OR

KT-AZER OR

FRHG0064

GRÖSSE ARTIKELNUMMER LAUFRADGRÖSSE

20

93LA1201

20





candy blue / pearl white - glossy



POWERKID 16

POWERKID AL

GHOST AL 16 Rigid

GHOST POWERKID 25.4 mm

GHOST POWERKID 460 mm

GHOST POWERKID 114 mm

Front: V-Brake, Rear: back pedal brake

GHOST Powerkid 27.2 mm

GHOST Powerkid

GHOST Powerkid

Vee Speedster 16 //
Vee Speedster 16

AL 16 //
AL 16

Joytech/KT

Joytech/KT

Kickstand

GRÖSSE ARTIKELNUMMER LAUFRADGRÖSSE

16

93PK1007





POWERKID 16

POWERKID AL

GHOST AL 16 Rigid

GHOST POWERKID 25.4 mm

GHOST POWERKID 460 mm

GHOST POWERKID 114 mm

Front: V-Brake, Rear: back pedal brake

GHOST Powerkid 27.2 mm

GHOST Powerkid

GHOST Powerkid

Vee Speedster 16 //
Vee Speedster 16

AL 16 //
AL 16

Joytech/KT

Joytech/KT

Kickstand

GRÖSSE ARTIKELNUMMER LAUFRADGRÖSSE

16

93PK1008

16





POWERKID 12

POWERKID AL

GHOST AL 12 Rigid

GHOST POWERKID 25.4 mm

GHOST POWERKID 460 mm

GHOST POWERKID 89 mm

Front: V-Brake, Rear: back pedal brake

GHOST Powerkid 27.2 mm

GHOST Powerkid

GHOST Powerkid

Vee Speedster 12 //
Vee Speedster 12

AL 12 //
AL 12

Joytech/KT

Joytech/KT

GRÖSSE ARTIKELNUMMER LAUFRADGRÖSSE

12

93PK1005

12





POWERKID 12

POWERKID AL

GHOST AL 12 Rigid

GHOST POWERKID 25.4 mm

GHOST POWERKID 460 mm

GHOST POWERKID 89 mm

Front: V-Brake, Rear: back pedal brake

GHOST Powerkid 27.2 mm

GHOST Powerkid

GHOST Powerkid

Vee Speedster 12 //
Vee Speedster 12

AL 12 //
AL 12

Joytech/KT

Joytech/KT

GRÖSSE ARTIKELNUMMER LAUFRADGRÖSSE

12

93PK1006

12





Dirty blue / metallic lime - glossy



POWERKIDDY 12

 POWERKIDDY AL

 GHOST AL 12 Rigid

 GHOST POWERKIDDY

 GHOST POWERKIDDY

 GHOST Powerkiddy 27.2 mm

 GHOST Powerkiddy

 GHOST Powerkiddy

 Vee Speedster 12 //
Vee Speedster 12

 AL 12 //
AL 12

 Joytech/KT

 Joytech/KT

GRÖSSE ARTIKELNUMMER LAUFRADGRÖSSE

12

93PK1001

12





POWERKIDDY 12

 POWERKIDDY AL

 GHOST AL 12 Rigid

 GHOST POWERKIDDY

 GHOST POWERKIDDY

 GHOST Powerkiddy 27.2 mm

 GHOST Powerkiddy

 GHOST Powerkiddy

 Vee Speedster 12 //
Vee Speedster 12

 AL 12 //
AL 12

 Joytech/KT

 Joytech/KT

GRÖSSE ARTIKELNUMMER LAUFRADGRÖSSE

12

93PK1003

12



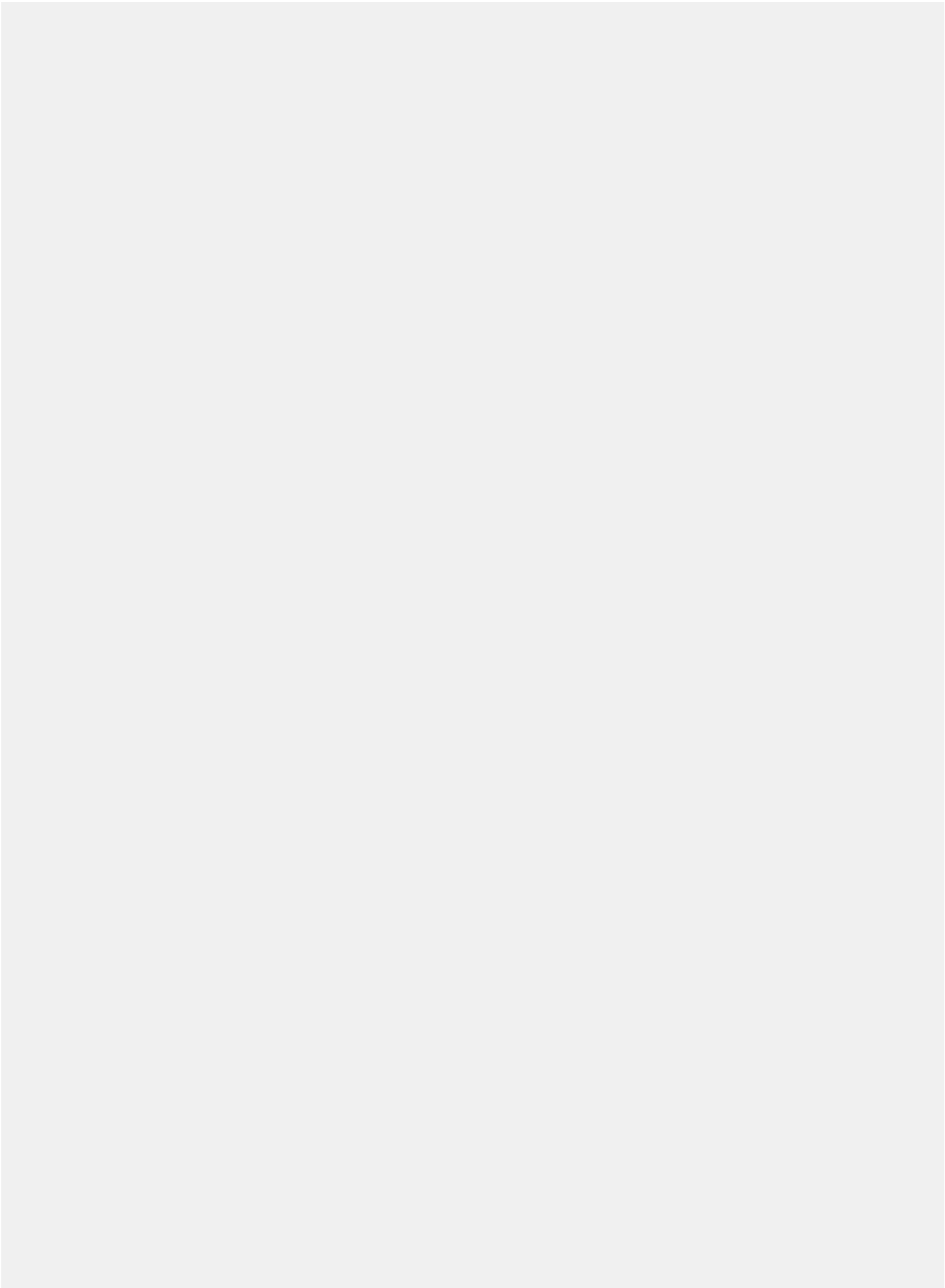

BIKES



RIOT

LECTOR

NIRVANA

KATO

LANAO

KIDS

SQUARE

ASKET



met. black / urban grey - matt



SQUARE TREKKING ESSENTIAL

SQUARE TREKKING AL

SR Suntour NEX HLO DS 63 mm

Ghost Dia. 31.8 mm

GHOST Dia. 31.8 mm 680 mm

Shimano Alivio RD-T4000 9-S

Shimano Altus SL-M2010

Shimano FC-T4010 48-36-26

Shimano CS-HG400-9 11-34

Shimano BR-MT200 160 mm Disc

GHOST SP DC1 31.6 mm

Justek 3050 HRN

Strummer semi-integrated

Shimano BB-ES300

Velo VLG-1752D2

Schwalbe Energizer Activ Plus 37-622 //
Schwalbe Energizer Activ Plus 37-622

Rodi Excalibur XC19 //
Rodi Excalibur XC19

Shimano DH-3D37-QR Hyb Dynamo

Shimano FH-TX505 QR 135 mm

Carrier

Pletscher RG40

Ursus Easy Center

Herrmans MR GO

Herrmans H-Trace

FRHG0004

GRÖSSE ARTIKELNUMMER LAUFRADGRÖSSE

S 31ST1013

M 31ST1014

L 31ST1015

XL 31ST1016





met. black / urban grey - matt



SQUARE TREKKING ESSENTIAL MID

SQUARE TREKKING AL

SR Suntour NEX HLO DS 63 mm

Ghost Dia. 31.8 mm

GHOST Dia. 31.8 mm 680 mm

Shimano Alivio RD-T4000 9-S

Shimano Altus SL-M2010

Shimano FC-T4010 48-36-26

Shimano CS-HG400-9 11-34

Shimano BR-MT200 160 mm Disc

GHOST SP DC1 31.6 mm

Justek 3050 HRN

Strummer semi-integrated

Shimano BB-ES300

Velo VLG-1752D2

Schwalbe Energizer Activ Plus 37-622 //
Schwalbe Energizer Activ Plus 37-622

Rodi Excalibur XC19 //
Rodi Excalibur XC19

Shimano DH-3D37-QR Hyb Dynamo

Shimano FH-TX505 QR 135 mm

Carrier

Pletscher RG40

Ursus Easy Center

Herrmans MR GO

Herrmans H-Trace

FRHG0004

| GRÖSSE | ARTIKELNUMMER | LAUFRADGRÖSSE |
|--------|---------------|---------------|
| XS | 31ST1019 | 28 |
| S | 31ST1020 | 28 |
| M | 31ST1021 | 28 |
| L | 31ST1022 | 28 |



light grey / warm grey - matt



SQUARE TREKKING

SQUARE TREKKING AL

SR Suntour NEX DS 63 mm

Ghost Dia. 31.8 mm

GHOST Dia. 31.8 mm 680 mm

Shimano Acera RD-M3020 8-S

Shimano SL-M315

Shimano FC-TY301 48-38-28

Shimano CS-HG31 11-34

Shimano BR-MT200 160 mm Disc

GHOST SP DC1 31.6 mm

Justek 3050 HRN

Strummer semi-integrated

Thun Jive 3.0 FS

Velo VLG-1752D2

Schwalbe Energizer Activ Plus 37-622 //
Schwalbe Energizer Activ Plus 37-622

Rodi Excalibur XC19 //
Rodi Excalibur XC19

Shimano DH-3D37-QR Hyb Dynamo

Shimano FH-TX505 QR 135 mm

Carrier

Pletscher RG40

Ursus Easy Center

Herrmans MR GO

Herrmans H-Trace

FRHG0004

| GRÖSSE | ARTIKELNUMMER | LAUFRADGRÖSSE |
|--------|---------------|---------------|
| S | 31ST1001 | 28 |
| M | 31ST1002 | 28 |
| L | 31ST1003 | 28 |
| XL | 31ST1004 | 28 |



light grey / warm grey - matt



SQUARE TREKKING MID

SQUARE TREKKING AL

SR Suntour NEX.DS 63 mm

Ghost Dia. 31.8 mm

GHOST Dia. 31.8 mm 680 mm

Shimano Acera RD-M3020 8-S

Shimano SL-M315

Shimano FC-TY301 48-38-28

Shimano CS-HG31 11-34

Shimano BR-MT200 160 mm Disc

GHOST SP DC1 31.6 mm

Justek 3050 HRN

Strummer semi-integrated

Thun Jive 3.0 FS

Velo VLG-1752D2

Schwalbe Energizer Activ Plus 37-622 //
Schwalbe Energizer Activ Plus 37-622

Rodi Excalibur XC19 //
Rodi Excalibur XC19

Shimano DH-3D37-QR Hyb Dynamo

Shimano FH-TX505 QR 135 mm

Carrier

Pletscher RG40

Ursus Easy Center

Herrmans MR GO

Herrmans H-Trace

FRHG0004

| GRÖSSE | ARTIKELNUMMER | LAUFRADGRÖSSE |
|--------|---------------|---------------|
| XS | 31ST1007 | 28 |
| S | 31ST1008 | 28 |
| M | 31ST1009 | 28 |
| L | 31ST1010 | 28 |





SQUARE CROSS ESSENTIAL

SQUARE CROSS AL

Rock Shox Paragon Gold RL 65 mm

Ghost Dia. 31.8 mm

GHOST Dia. 31.8 mm 680 mm

SRAM SX Eagle 12-S

SRAM SX Eagle

SRAM FC S650 38T

SRAM PG-1210 11-50

Shimano BR-MT200 160 mm Disc

GHOST SP DC1 31.6 mm

Justek 3050 HRN

Strummer semi-integrated

SRAM Powerspline

Velo VLG-1751D2

Schwalbe Smart Sam Performance 47-622 //
Schwalbe Smart Sam Performance 47-622

Rodi Excalibur XC19 //
Rodi Excalibur XC19

Shimano HB-TX505 QR 100 mm

Shimano FH-TX505 QR 135 mm

FRHG0004

| GRÖSSE | ARTIKELNUMMER | LAUFRADGRÖSSE |
|--------|---------------|---------------|
| S | 31SC1013 | 28 |
| M | 31SC1014 | 28 |
| L | 31SC1015 | 28 |
| XL | 31SC1016 | 28 |



blue grey / dirty blue - matt



SQUARE CROSS ESSENTIAL MID

SQUARE CROSS AL

Rock Shox Paragon Gold RL 65 mm

Ghost Dia. 31.8 mm

GHOST Dia. 31.8 mm 680 mm

SRAM SX Eagle 12-S

SRAM SX Eagle

SRAM FC S650 38T

SRAM PG-1210 11-50

Shimano BR-MT200 160 mm Disc

GHOST SP DC1 31.6 mm

Justek 3050 HRN

Strummer semi-integrated

SRAM Powerspline

Velo VLG-1751D2

Schwalbe Smart Sam Performance 47-622 //
Schwalbe Smart Sam Performance 47-622

Rodi Excalibur XC19 //
Rodi Excalibur XC19

Shimano HB-TX505 QR 100 mm

Shimano FH-TX505 QR 135 mm

FRHG0004

| GRÖSSE | ARTIKELNUMMER | LAUFRADGRÖSSE |
|--------|---------------|---------------|
| XS | 31SC1019 | 28 |
| S | 31SC1020 | 28 |
| M | 31SC1021 | 28 |
| L | 31SC1022 | 28 |



light grey / dark grey - matt



SQUARE CROSS

SQUARE CROSS AL

SR Suntour NEX DS 63 mm

Ghost Dia. 31.8 mm

GHOST Dia. 31.8 mm 680 mm

Shimano Alivio RD-M3100 9-S

Shimano Altus SL-M2010

Shimano FC-T3010 44-32-22

Shimano CS-HG400-9 11-34

Shimano BR-MT200 160 mm Disc

GHOST SP DC1 31.6 mm

Justek 3050 HRN

Strummer semi-integrated

Prestine PT-6621

Velo VLG-1751D2

Schwabe Smart Sam Performance 47-622 //
Schwabe Smart Sam Performance 47-622

Rodi Excalibur XC19 //
Rodi Excalibur XC19

Shimano HB-TX505 QR 100 mm

Shimano FH-TX505 QR 135 mm

FRHG0004

| GRÖSSE | ARTIKELNUMMER | LAUFRADGRÖSSE |
|--------|---------------|---------------|
| S | 31SC1001 | 28 |
| M | 31SC1002 | 28 |
| L | 31SC1003 | 28 |
| XL | 31SC1004 | 28 |



light grey / dark grey - matt



SQUARE CROSS MID

| | | |
|-----------------------------|------------------------------|--|
| SQUARE CROSS AL | Shimano CS-HG400-9 11-34 | Schwalbe Smart Sam Performance 47-622 // Schwalbe Smart Sam Performance 47-622 |
| SR Suntour NEX DS 63 mm | Shimano BR-MT200 160 mm Disc | Rodi Excalibur XC19 // Rodi Excalibur XC19 |
| Ghost Dia. 31.8 mm | GHOST SP DC1 31.6 mm | Shimano HB-TX505 QR 100 mm |
| GHOST Dia. 31.8 mm 680 mm | Justek 3050 HRN | Shimano FH-TX505 QR 135 mm |
| Shimano Alivio RD-M3100 9-S | Strummer semi-integrated | FRHG0004 |
| Shimano Altus SL-M2010 | Prestine PT-6621 | |
| Shimano FC-T3010 44-32-22 | Velo VLG-1751D2 | |

| GRÖSSE | ARTIKELNUMMER | LAUFRADGRÖSSE |
|--------|---------------|---------------|
| XS | 31SC1007 | 28 |
| S | 31SC1008 | 28 |
| M | 31SC1009 | 28 |
| L | 31SC1010 | 28 |



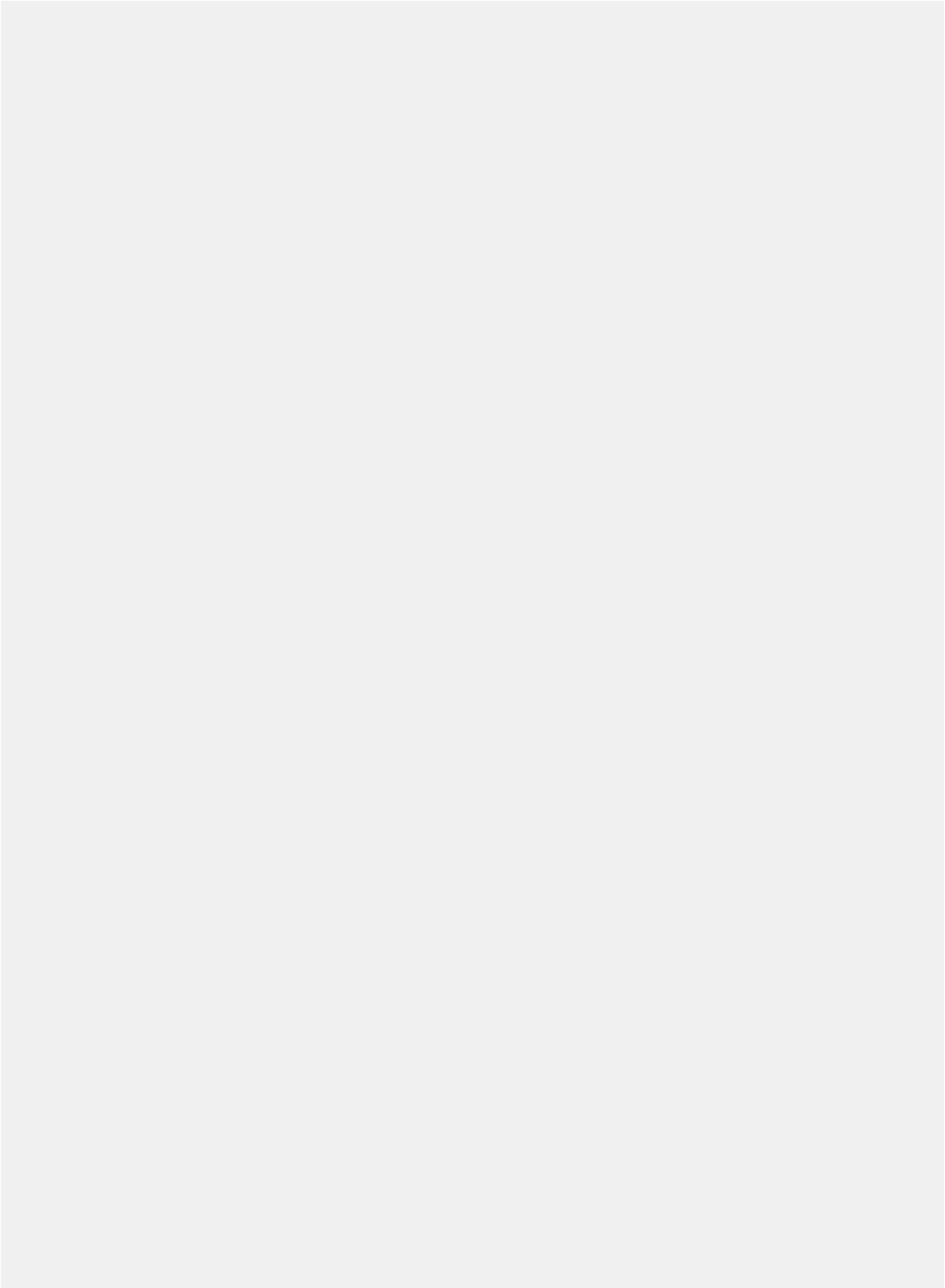

BIKES



RIOT

LECTOR

NIRVANA

KATO

LANAO

KIDS

SQUARE

ASKET

met. rusted dark red / black - matt



SUPER FIT
by GHOST



ASKET ADVANCED

ASKET AL

GHOST Carbon

Ghost Dia. 31.8 mm

Gravel Bar RA120A 420 mm (XS) 440 mm (S) 460 mm (M) 480 mm (L) 500 mm (XL)

Shimano GRX RD-RX812 11-S

Shimano GRX ST-RX600

Shimano GRX FC-RX810 40T

Shimano XT CS-M8000 11-42

Shimano GRX BR-RX400 160 mm Disc

GND 51 27.2 mm

Selle Royal SRX

Acros

Shimano SM-BBR60

FRHG0065

Fizik Tempo Bondcrush

Maxxis Ravager Exo TR 40-622 //
Maxxis Ravager Exo TR 40-622

WTB ST i25 //
WTB ST i25

Shimano HB-R7070 12x100 mm

Shimano FH-R7070 12x142 mm

| GRÖSSE | ARTIKELNUMMER | LAUFRADGRÖSSE |
|--------|---------------|---------------|
| XS | 31AK1041 | 28 |
| S | 31AK1042 | 28 |
| M | 31AK1043 | 28 |
| L | 31AK1044 | 28 |
| XL | 31AK1045 | 28 |



met. rusted dark red / black - matt



SUPER FIT
by GHOST



ASKET ADVANCED EQ

| | | |
|--|--|---|
| ASKET AL | Shimano GRX BR-RX400 160 mm Disc | WTB ST i25 // WTB ST i25 |
| GHOST Carbon | GND 51 27.2 mm | Shimano HB-RS470 12x100 mm |
| Ghost Dia. 31.8 mm | Selle Royal SRX | Shimano FH-MT400 12x142 mm |
| Gravel Bar RA120A 420 mm (XS) 440 mm (S) 460 mm (M) 480 mm (L) 500 mm (XL) | Acros | Acepac, bar harness Black |
| Shimano GRX RD-RX812 11-S | Shimano SM-BBR60 | Acepac, bar drybag 8L Black |
| Shimano GRX ST-RX600 | FRHG0065 | Acepac, saddle harness Black |
| Shimano GRX FC-RX810 40T | Fizik Tempo Bondcrush | Acepac, saddle drybag 16L Black |
| Shimano XT CS-M8000 11-42 | Maxxis Ravager Exo TR 40-622 // Maxxis Ravager Exo TR 40-622 | Acepac, zip frame bag L Black (for frame size: M, L, XL) Acepac Fuel Bag L (for frame size: XS, S) |

| GRÖSSE | ARTIKELNUMMER | LAUFRADGRÖSSE |
|--------|---------------|---------------|
| XS | 31AK1048 | 28 |
| S | 31AK1049 | 28 |
| M | 31AK1050 | 28 |
| L | 31AK1051 | 28 |
| XL | 31AK1052 | 28 |





met. dark blue / pearl blue green - matt



SUPER FIT
by GHOST



ASKET ESSENTIAL

ASKET AL

GHOST Carbon

Ghost Dia. 31.8 mm

Gravel Bar RA120A 420 mm (XS) 440 mm (S) 460 mm (M) 480 mm (L) 500 mm (XL)

Shimano GRX RD-RX400 10-S

Shimano GRX FD-RX400

Shimano GRX ST-RX400

Shimano GRX FC-RX600 46-30T

Shimano CS-HG50-10 11-36

Shimano GRX BR-RX400 160 mm Disc

GND 51 27.2 mm

Selle Royal SRX

Acros

Shimano BSA

FRHG0065

Fizik Tempo Bondcrush

Maxxis Ravager Exo TR 40-622 //
Maxxis Ravager Exo TR 40-622

WTB ST i25 //
WTB ST i25

Shimano HB-RS470 12x100 mm

Shimano FH-MT400 12x142 mm

GRÖSSE ARTIKELNUMMER LAUFRADGRÖSSE

| | | |
|----|----------|----|
| XS | 31AK1028 | 28 |
| S | 31AK1029 | 28 |
| M | 31AK1030 | 28 |
| L | 31AK1031 | 28 |
| XL | 31AK1032 | 28 |



black / light kaki - matt

SUPER FIT
by GHOST



ASKET ESSENTIAL

ASKET AL

GHOST Carbon

Ghost Dia. 31.8 mm

Gravel Bar RA120A 420 mm (XS) 440 mm (S) 460 mm (M) 480 mm (L) 500 mm (XL)

Shimano GRX RD-RX400 10-S

Shimano GRX FD-RX400

Shimano GRX ST-RX400

Shimano GRX FC-RX600 46-30T

Shimano CS-HG50-10 11-36

Shimano GRX BR-RX400 160 mm Disc

GND 51 27.2 mm

Selle Royal SRX

Acros

Shimano BSA

FRHG0065

Fizik Tempo Bondcrush

Maxxis Ravager Exo TR 40-622 //
Maxxis Ravager Exo TR 40-622

WTB ST i25 //
WTB ST i25

Shimano HB-RS470 12x100 mm

Shimano FH-MT400 12x142 mm

GRÖSSE ARTIKELNUMMER LAUFRADGRÖSSE

| | | |
|----|----------|----|
| XS | 31AK1021 | 28 |
| S | 31AK1022 | 28 |
| M | 31AK1023 | 28 |
| L | 31AK1024 | 28 |
| XL | 31AK1025 | 28 |





black / light kaki - matt



SUPER FIT
by GHOST



ASKET ESSENTIAL EQ

ASKET AL

GHOST Carbon

Ghost Dia. 31.8 mm

Gravel Bar RA120A 420 mm (XS) 440 mm (S) 460 mm (M) 480 mm (L) 500 mm (XL)

Shimano GRX RD-RX400 10-S

Shimano GRX FD-RX400

Shimano GRX ST-RX400

Shimano GRX FC-RX600 46-30T

Shimano CS-HG50-10 11-36

Shimano GRX BR-RX400 160 mm Disc

GND 51 27.2 mm

Selle Royal SRX

Acros

Shimano BSA

FRHG0065

Fizik Tempo Bondcrush

Maxxis Ravager Exo TR 40-622 //
Maxxis Ravager Exo TR 40-622

WTB ST i25 //
WTB ST i25

Shimano HB-RS470 12x100 mm

Shimano FH-MT400 12x142 mm

Racktime Light IT 2.0

Curana Apollo 55

Lezyne Hecto Pro 65

Lezyne Hecto Pro 65

GRÖSSE ARTIKELNUMMER LAUFRADGRÖSSE

| | | |
|----|----------|----|
| XS | 31AK1034 | 28 |
| S | 31AK1035 | 28 |
| M | 31AK1036 | 28 |
| L | 31AK1037 | 28 |
| XL | 31AK1038 | 28 |



dark grey / shark blue - matt

SUPER FIT
by GHOST



ASKET

ASKET AL

GHOST Carbon

Ghost Dia. 31.8 mm

Gravel Bar RA120A 420 mm (XS) 440 mm (S) 460 mm (M) 480 mm (L) 500 mm (XL)

Shimano Sora RD-R3000 9-S

Shimano Sora FD-R3030

Shimano Sora ST-R3000

FSA CK-C201ST 46-30T

Shimano CS-HG400-9 11-34

Shimano BR-RS305 160 mm Disc

GND 51 27.2 mm

Selle Royal SRX

Acros

Feimin FP-B908N

FRHG0065

Fizik Tempo Bondcrush

Maxxis Ravager Exo TR 40-622 //
Maxxis Ravager Exo TR 40-622

WTB ST i25 //
WTB ST i25

Shimano HB-RS470 12x100 mm

Shimano FH-MT400 12x142 mm

| GRÖSSE | ARTIKELNUMMER | LAUFRADGRÖSSE |
|--------|---------------|---------------|
| XS | 31AK1001 | 28 |
| S | 31AK1002 | 28 |
| M | 31AK1003 | 28 |
| L | 31AK1004 | 28 |
| XL | 31AK1005 | 28 |



dark grey / shark blue - matt



ASKET EQ

| |
|--|
| ASKET AL |
| GHOST Carbon |
| Ghost Dia. 31.8 mm |
| Gravel Bar RA120A 420 mm (XS) 440 mm (S) 460 mm (M) 480 mm (L) 500 mm (XL) |
| Shimano Sora RD-R3000 9-S |
| Shimano Sora FD-R3030 |
| Shimano Sora ST-R3000 |
| FSA CK-C201ST 46-30T |

| |
|------------------------------|
| Shimano CS-HG400-9 11-34 |
| Shimano BR-RS305 160 mm Disc |
| GND 51 27.2 mm |
| Selle Royal SRX |
| Acros |
| Feimin FP-B908N |
| FRHG0065 |
| Fizik Tempo Bondcrush |

| |
|--|
| Maxxis Ravager Exo TR 40-622 // Maxxis Ravager Exo TR 40-622 |
| WTB ST i25 // WTB ST i25 |
| Shimano HB-RS470 12x100 mm |
| Shimano FH-MT400 12x142 mm |
| Racktime Light IT 2.0 |
| Curana Apollo 55 |
| Lezyne Hecto Pro 65 |
| Lezyne Hecto Pro 65 |

| GRÖSSE | ARTIKELNUMMER | LAUFRADGRÖSSE |
|--------|---------------|---------------|
| XS | 31AK1008 | 28 |
| S | 31AK1009 | 28 |
| M | 31AK1010 | 28 |
| L | 31AK1011 | 28 |
| XL | 31AK1012 | 28 |



very dark purple / light grey - matt

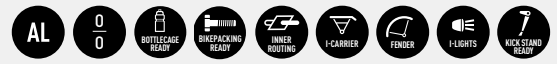

ASKET EQ

| |
|--|
| ASKET AL |
| GHOST Carbon |
| Ghost Dia. 31.8 mm |
| Gravel Bar RA120A 420 mm (XS) 440 mm (S) 460 mm (M) 480 mm (L) 500 mm (XL) |
| Shimano Sora RD-R3000 9-S |
| Shimano Sora FD-R3030 |
| Shimano Sora ST-R3000 |
| FSA CK-C201ST 46-30T |

| |
|------------------------------|
| Shimano CS-HG400-9 11-34 |
| Shimano BR-RS305 160 mm Disc |
| GND 51 27.2 mm |
| Selle Royal SRX |
| Acros |
| Feimin FP-B908N |
| FRHG0065 |
| Fizik Tempo Bondcrush |

| |
|--|
| Maxxis Ravager Exo TR 40-622 // Maxxis Ravager Exo TR 40-622 |
| WTB ST i25 // WTB ST i25 |
| Shimano HB-RS470 12x100 mm |
| Shimano FH-MT400 12x142 mm |
| Racktime Light IT 2.0 |
| Curana Apollo 55 |
| Lezyne Hecto Pro 65 |
| Lezyne Hecto Pro 65 |

| GRÖSSE | ARTIKELNUMMER | LAUFRADGRÖSSE |
|--------|---------------|---------------|
| XS | 31AK1015 | 28 |
| S | 31AK1016 | 28 |
| M | 31AK1017 | 28 |
| L | 31AK1018 | 28 |
| XL | 31AK1019 | 28 |



met. light grey / shark blue - matt / glossy



URBAN ASKET

| | | |
|-------------------------------------|------------------------------|--|
| ASKET AL | FSA CK-C201ST 46-30T | FRHG0065 |
| GHOST Carbon | Shimano CS-HG400-9 11-34 | Velo VLG-1751D2 |
| Ghost Dia. 31.8 mm | Shimano BR-RS305 160 mm Disc | Maxxis Roamer 44-622 // Maxxis Roamer 44-622 |
| Ground Fiftyone Dia. 31.8 mm 660 mm | GND 51 27.2 mm | WTB ST i25 // WTB ST i25 |
| Shimano Sora RD-R3000 9-S | Selle Royal SRX | Shimano HB-RS470 12x100 mm |
| Shimano Sora FD-R3030 | Acros | Shimano FH-MT400 12x142 mm |
| Shimano Sora SL-R3000 | Feimin FP-B908N | |

| GRÖSSE | ARTIKELNUMMER | LAUFRADGRÖSSE |
|--------|---------------|---------------|
| XS | 31AK1055 | 28 |
| S | 31AK1056 | 28 |
| M | 31AK1057 | 28 |
| L | 31AK1058 | 28 |
| XL | 31AK1059 | 28 |





E-BIKES

PATH RIOT

E-TERU

E-RIOT

PATH ASKET

E-ASX

carbon / dark grey - glossy

- FAZUA
- 430 Wh
- +210 mm READY
- LC
- 150/140
- TUBE LES
- USB
- ONE-PIECE
- TRACTION LINK
- EIGHT PINS

SUPER FIT
by GHOST



PATH RIOT LTD

PATH RIOT CF

Fox 36 Float Factory FIT4 150 mm

Fox Float DPS Factory 140 mm

Syntace Megaforce3 Dia. 31.8 mm

Syntace Vector Carbon High 35 Dia. 31.8 780/35

Shimano XTR RD-M9100 12-S

Shimano XTR SL-M9100

Rotor 34T

Shimano XTR CS-M9100 10-51

Formula Cura 4 203 mm Disc

DT Swiss XMC 1200 Spline 30 mm 15x110 mm //
DT Swiss XMC 1200 Spline 30 mm 12x148 mm

Eightpins hydraulic 34.9 mm

Fizik Antares Versus Evo 00 Adaptive

Acros Blocklock 135° AZX-582

SRAM UDH

WTB Wafel

Maxxis Assegai 3C MaxxTerra Exo 2.5 //
Maxxis Dissector 3C MaxxTerra Exo+ 2.4

Fazua LED Hub

Fazua Ride 60

Fazua Energy 430 Wh

Fazua Charger 3A

GRÖSSE ARTIKELNUMMER LAUFRADGRÖSSE

| | | |
|----|----------|----|
| S | 31PR1013 | 29 |
| M | 31PR1014 | 29 |
| L | 31PR1015 | 29 |
| XL | 31PR1016 | 29 |



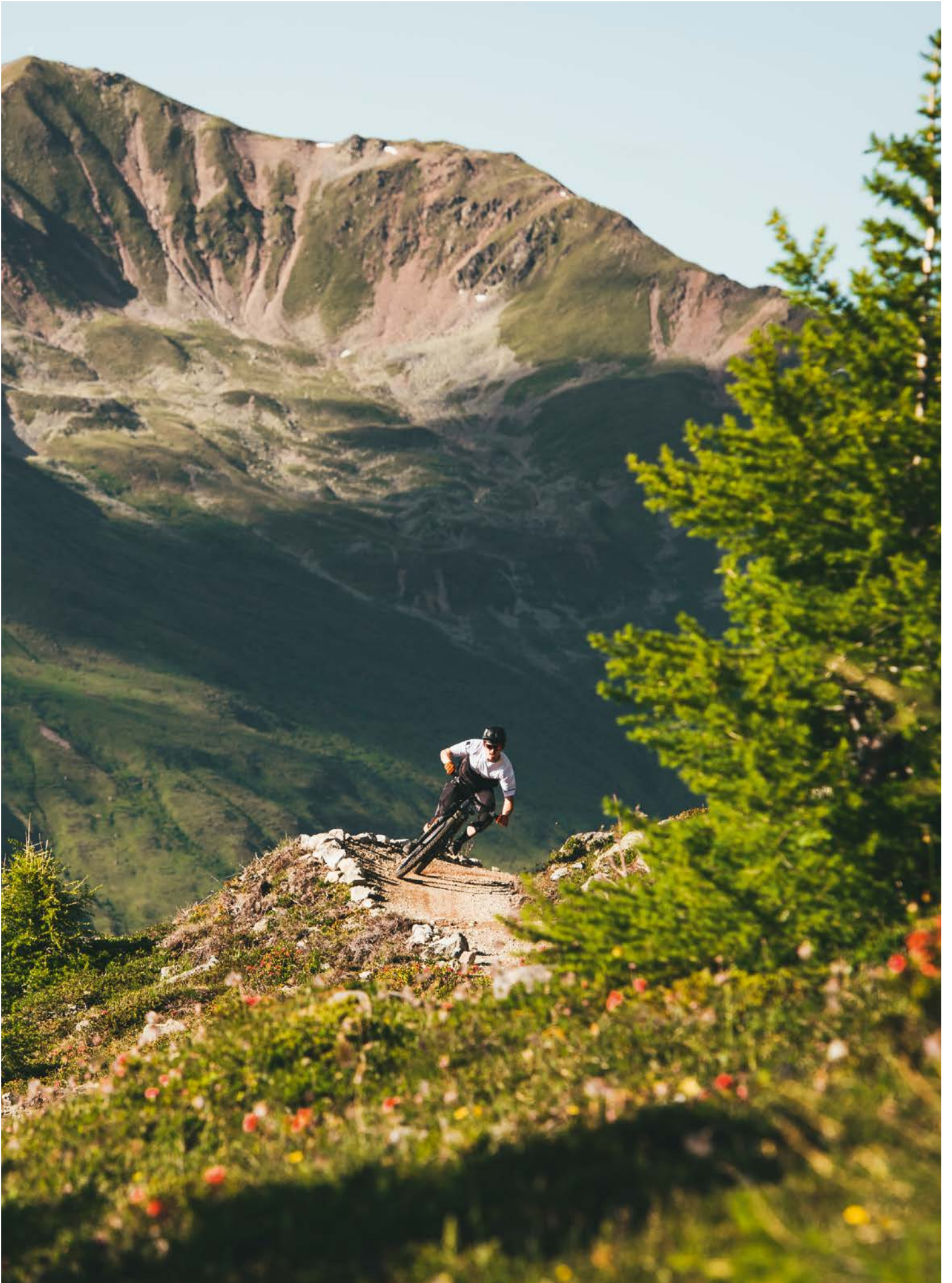



warm grey / dark chocolate - glossy



SUPER FIT
by GHOST



PATH RIOT FULL PARTY

PATH RIOT CF

Fox 38 Float Factory GRIP2 eMTB+ 160 mm

Fox Float X2 Factory 140 mm

Ground Fiftyone Dia. 31.8 mm

Ground Fiftyone Dia. 31.8 mm 760/15 (S) 800/27 (M-XL)

Shimano XTR RD-M9100 12-S

Shimano XTR SL-M9100

Rotor 34T

Shimano XT CS-M8100 10-51

Formula Cura 4 203 mm Disc

Syntace W33i 15x110 mm //
Syntace W33i 12x148 mm

Eightpins hydraulic 34.9 mm

WTB Volt

Acros Blocklock 135° AZX-582

SRAM UDH

WTB Wafel

Maxxis Assegai 3C MaxxTerra Exo+ 2.6 //
Maxxis Dissector 3C MaxxGrip Double Down 2.4

Fazua LED Hub

Fazua Ride 60

Fazua Energy 430 Wh

Fazua Charger 3A

GRÖSSE ARTIKELNUMMER LAUFRADGRÖSSE

| | | |
|----|----------|----|
| S | 31PR1007 | 29 |
| M | 31PR1008 | 29 |
| L | 31PR1009 | 29 |
| XL | 31PR1010 | 29 |



grey 1 / pearl light grey - glossy



PATH RIOT ADVANCED

| | | |
|---|--|--------------------------------------|
| PATH RIOT CF | Shimano Deore CS-M6100 10-51 | WTB ST Light i30 // WTB ST Light i30 |
| Fox 38 Float Performance eMTB+ 160 mm | Formula Cura 4 203 mm Disc | DT Swiss 370 Classic 15x110 mm |
| Fox Float X2 Performance 140 mm | Eightpins hydraulic 34.9 mm | DT Swiss 370 Classic 12x148 mm |
| Ground Fiftyone Dia. 31.8 mm | WTB Volt | Fazua LED Hub |
| Ground Fiftyone Dia. 31.8 mm 760/15 (S) 800/27 (M-XL) | Acros Blocklock 135° AZX-582 | Fazua Ride 60 |
| Shimano XT RD-M8100 12-S | SRAM UDH | Fazua Energy 430 Wh |
| Shimano SLX SL-M7100 | WTB Wafel | Fazua Charger 3A |
| Rotor 34T | Maxxis Assegai 3C MaxxTerra Exo+ 2.6 // Maxxis Dissector 3C MaxxGrip Double Down 2.4 | |

| GRÖSSE | ARTIKELNUMMER | LAUFRADGRÖSSE |
|--------|---------------|---------------|
| S | 31PR1001 | 29 |
| M | 31PR1002 | 29 |
| L | 31PR1003 | 29 |
| XL | 31PR1004 | 29 |



E-BIKES

PATH RIOT

E-TERU

E-RIOT

PATH ASKET

E-ASX

grey / black - matt / glossy

SUPER FIT
by GHOST



E-RIOT EN FULL PARTY

E-RIOT AL

Fox 38 Float Factory GRIP2 eMTB+ 170 mm

Fox DHX2 Factory 160 mm

Race Face Aeffect R Dia. 35 mm

Race Face Aeffect R Dia. 35 mm 780/20

Shimano XT RD-M8100 12-S

Shimano XT SL-M8100

e*thirteen e*spec Plus 34T

Shimano XT CS-M8100 10-51

Formula Cura 4 203 mm Disc

DT Swiss H1900 Spline 30 mm 15x110 mm //
DT Swiss H1900 Spline 30 mm 12x148 mm

Ghost Alpha 1 34.9 mm 125 (S) 150 (M) 170 (L/XL)

Fizik Terra Aidon

Acros Blocklock 135° AZX-582

SRAM UDH

Race Face Half Nelson

Maxxis Assegai 3C MaxxGrip Exo+ 2.5 (S 27,5"; M-XL 29") //
Maxxis Minion DHR II 3C MaxxTerra Exo+ 2.6 (S 27,5"; M-XL 29")

Bosch Kiox 300

Bosch CX-R

Bosch Power Tube 750 Wh

Bosch Charger 4 Ah

| GRÖSSE | ARTIKELNUMMER | LAUFRADGRÖSSE |
|--------|---------------|---------------|
| S | 31ER1039 | |
| M | 31ER1040 | |
| L | 31ER1041 | |
| XL | 31ER1042 | |





met. azur blue / dark blue - glossy



SUPER FIT
by GHOST



E-RIOT EN PRO

E-RIOT AL

Fox 38 Float Performance eMTB+ 170 mm

Fox DHX Performance 160 mm

Ground Fiftyone Dia. 31.8 mm

Ground Fiftyone Dia. 31.8 mm 760/15 (S) 780/25 (M-XL)

Shimano XT RD-M8100 12-S

Shimano XT SL-M8100

e*thirteen e*spec Plus 34T

Shimano SLX CS-M7100 10-51

Shimano Deore BR-M6120 203 mm Disc

Ghost Alpha 1 34.9 mm 125 (S) 150 (M) 170 (L/XL)

Fizik Terra Aidon

Acros Blocklock 135° AZX-582

SRAM UDH

WTB Wafel

Maxxis Assegai 3C MaxxGrip Exo+ 2.5 (S 27.5"; M-XL 29") //
Maxxis Minion DHR II 3C MaxxTerra Exo+ 2.6 (S 27.5"; M-XL 29")

WTB ST i30 //
WTB ST i30

DT Swiss 370 Classic 15x110 mm

DT Swiss 370 Classic 12x148 mm

Bosch Kiox 300

Bosch Performance Line CX

Bosch Power Tube 750 Wh

Bosch Charger 4 Ah

| GRÖSSE | ARTIKELNUMMER | LAUFRADGRÖSSE |
|--------|---------------|---------------|
| S | 31ER1033 | 27.5 |
| M | 31ER1034 | 29 |
| L | 31ER1035 | 29 |
| XL | 31ER1036 | 29 |





dark green / met. green - glossy



SUPER FIT
by GHOST



E-RIOT EN UNIVERSAL

E-RIOT AL

Rock Shox ZEB Base 170 mm

Rock Shox Super Deluxe Coil Select R 160 mm

Ground Fiftyone Dia. 31.8 mm

Ground Fiftyone Dia. 31.8 mm 760/15 (S) 780/25 (M-XL)

SRAM GX Eagle 12-S

SRAM GX Eagle Single Click

e*thirteen e*spec Plus 34T

SRAM PG-1230 11-50

SRAM DB8 200 mm Disc

Ghost Alpha 1 34.9 mm 125 (S) 150 (M) 170 (L/XL)

Fizik Terra Aidon

Acros Blocklock 135° AZX-582

SRAM UDH

WTB Wafel

Maxxis Assegai 3C MaxxGrip Exo+ 2.5 (S 27.5"; M-XL 29") //
Maxxis Minion DHR II 3C MaxxTerra Exo+ 2.6 (S 27.5"; M-XL 29")

WTB ST i30 //
WTB ST i30

Shimano HB-MT400-B 15x110 mm

Shimano FH-MT400-B 12x148 mm

Bosch Kiox 300

Bosch Performance Line CX

Bosch Power Tube 750 Wh

Bosch Charger 4 Ah

| GRÖSSE | ARTIKELNUMMER | LAUFRADGRÖSSE |
|--------|---------------|---------------|
| S | 31ER1027 | 27.5 |
| M | 31ER1028 | 29 |
| L | 31ER1029 | 29 |
| XL | 31ER1030 | 29 |



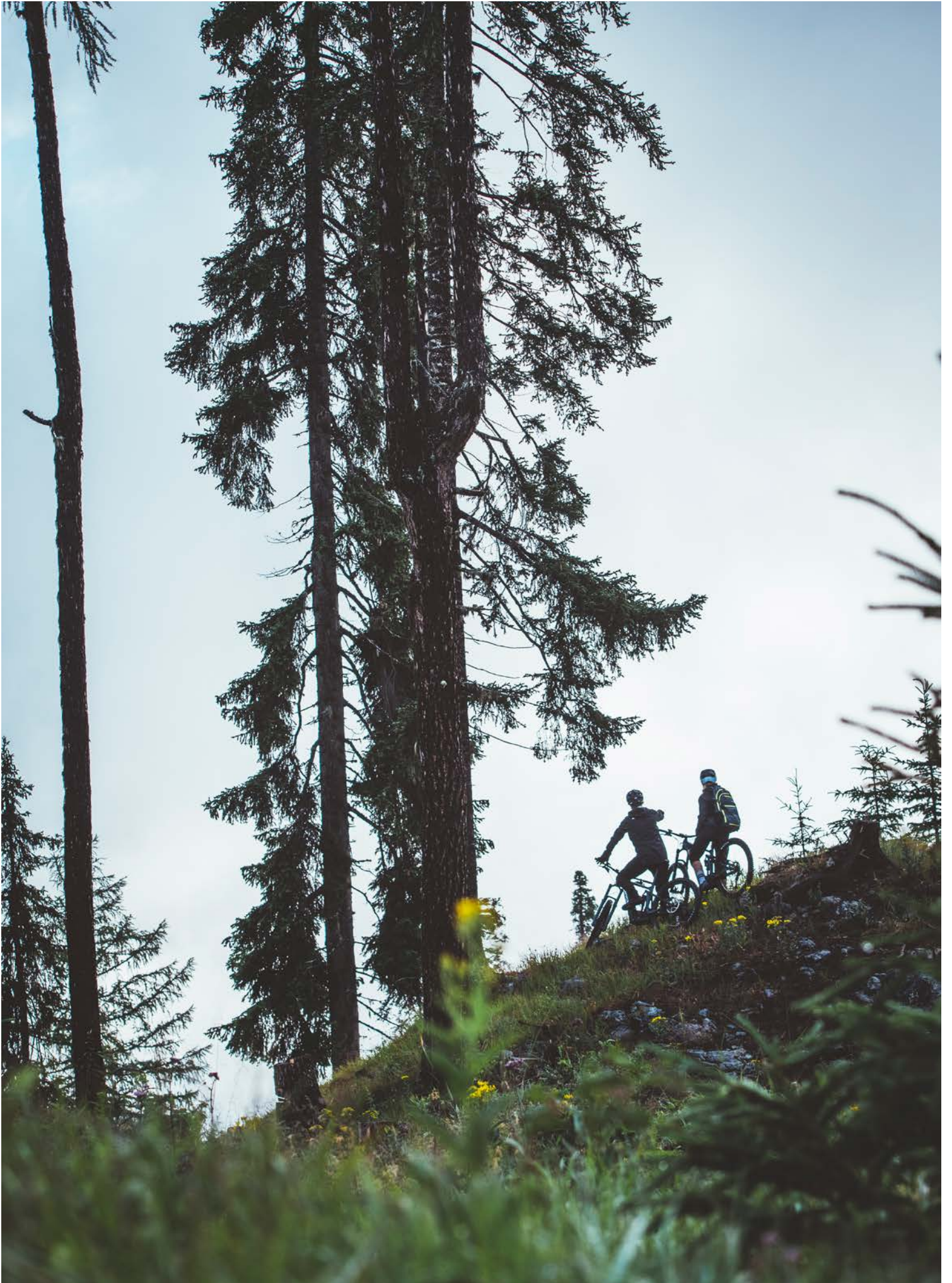



ZEB Ultimate grey / black - matt



SUPER FIT
by GHOST



E-RIOT AM FULL PARTY

E-RIOT CF

Rock Shox ZEB Ultimate 160 mm

Rock Shox Super Deluxe Ultimate RC2T 160 mm

Race Face Turbine R Dia. 35 mm

Race Face Turbine R Dia. 35 mm 780/20

SRAM X01 Eagle 12-S

SRAM GX Eagle Single Click

e*thirteen e*spec Plus 34T

SRAM XG 1275 10-52

SRAM Code RSC 200 mm Disc

DT Swiss H1900 Spline 30 mm 15x110 mm //
DT Swiss H1900 Spline 30 mm 12x148 mm

Eightpins hydraulic 34.9 mm

Fizik Terra Aidon

Acros Blocklock 135° AZX-582

SRAM UDH

Race Face Half Nelson

Maxxis Minion DHF 3C MaxxTerra Exo+ 2.5 (S 27.5"; M-XL 29") //
Maxxis Minion DHR II 3C MaxxTerra Exo+ 2.6 (S 27.5"; M-XL 29")

Bosch Kiox 300

Bosch Performance Line CX

Bosch Power Tube 750 Wh

Bosch Charger 4 Ah

GRÖSSE ARTIKELNUMMER LAUFRADGRÖSSE

| | | |
|----|----------|--|
| S | 31ER1051 | |
| M | 31ER1052 | |
| L | 31ER1053 | |
| XL | 31ER1054 | |



met. turquoise / black - matt

SUPER FIT
by GHOST



E-RIOT AM PRO

E-RIOT CF

Rock Shox ZEB Select 160 mm

Rock Shox Super Deluxe Select R 160 mm

Ground Fiftyone Dia. 31.8 mm

Ground Fiftyone Dia. 31.8 mm 760/15 (S) 780/25 (M-XL)

SRAM GX Eagle 12-S

SRAM NX Eagle Single Click

e*thirteen e*spec Plus 34T

SRAM PG-1230 11-50

Shimano BR-MT520 203 mm Disc

Ghost Alpha 1 34.9 mm 125 (S) 150 (M) 170 (L/XL)

Fizik Terra Aidon

Acros Blocklock 135° AZX-582

SRAM UDH

WTB Wafel

Maxxis Minion DHF 3C MaxxTerra Exo+ 2.5 (S 27.5"; M-XL 29") // Maxxis Minion DHR II 3C MaxxTerra Exo+ 2.6 (S 27.5"; M-XL 29")

WTB ST i30 // WTB ST i30

Shimano HB-MT400-B 15x110 mm

Shimano FH-MT400-B 12x148 mm

Bosch Kiox 300

Bosch Performance Line CX

Bosch Power Tube 750 Wh

Bosch Charger 4 Ah

| GRÖSSE | ARTIKELNUMMER | LAUFRADGRÖSSE |
|--------|---------------|---------------|
| S | 31ER1045 | 27.5 |
| M | 31ER1046 | 29 |
| L | 31ER1047 | 29 |
| XL | 31ER1048 | 29 |





black / dirty orange - glossy / matt



SUPER FIT
by GHOST



E-RIOT AM ADVANCED

E-RIOT CF

Rock Shox 35 Silver TK Solo Air 160 mm

Rock Shox Super Deluxe Select R 160 mm

Ground Fiftyone Dia. 31.8 mm

Ground Fiftyone Dia. 31.8 mm
760/15 (S) 780/15 (M-L) 780/40 (XL)

SRAM SX Eagle 12-S

SRAM SX Eagle Single Click

e*thirteen e*spec Plus 34T

SRAM PG-1210 11-50

Shimano BR-MT420 203 mm Disc

Limotec Alpha 1 34.9 mm
125 (S) 150 (M) 170 (L/XL)

Fizik Terra Aidon

Acros Blocklock 135° AZX-582

SRAM UDH

WTB Wafel

Maxxis Minion DHF 3C MaxxTerra Exo+ 2.5 //
Maxxis Minion DHR II 3C MaxxTerra Exo+ 2.6

WTB ST i30 //
WTB ST i30

Shimano HB-MT400-B 15x110 mm

Shimano FH-MT400-B 12x148 mm

Bosch Kiox 300

Bosch Performance Line CX

Bosch Power Tube 750 Wh

Bosch Charger 4 Ah

| GRÖSSE | ARTIKELNUMMER | LAUFRADGRÖSSE |
|--------|---------------|---------------|
| S | 93ER1031 | 27.5 |
| M | 93ER1032 | 29 |
| L | 93ER1033 | 29 |
| XL | 93ER1034 | 29 |





dirty blue / black - glossy / matt



SUPER FIT
by GHOST



E-RIOT AM ADVANCED

E-RIOT CF

Rock Shox 35 Silver TK Solo Air 160 mm

Rock Shox Super Deluxe Select R 160 mm

Ground Fiftyone Dia. 31.8 mm

Ground Fiftyone Dia. 31.8 mm
760/15 (S) 780/15 (M-L) 780/40 (XL)

SRAM SX Eagle 12-S

SRAM SX Eagle Single Click

e*thirteen e*spec Plus 34T

SRAM PG-1210 11-50

Shimano BR-MT420 203 mm Disc

Limotec Alpha 1 34.9 mm
125 (S) 150 (M) 170 (L/XL)

Fizik Terra Aidon

Acros Blocklock 135° AZX-582

SRAM UDH

WTB Wafel

Maxxis Minion DHF 3C MaxxTerra Exo+ 2.5 //
Maxxis Minion DHR II 3C MaxxTerra Exo+ 2.6

WTB ST i30 //
WTB ST i30

Shimano HB-MT400-B 15x110 mm

Shimano FH-MT400-B 12x148 mm

Bosch Kiox 300

Bosch Performance Line CX

Bosch Power Tube 750 Wh

Bosch Charger 4 Ah

| GRÖSSE | ARTIKELNUMMER | LAUFRADGRÖSSE |
|--------|---------------|---------------|
| S | 93ER1025 | 27.5 |
| M | 93ER1026 | 29 |
| L | 93ER1027 | 29 |
| XL | 93ER1028 | 29 |



dark grey / black - matt

SUPER FIT
by GHOST



E-RIOT AM UNIVERSAL

E-RIOT AL

Fox 38 Float Performance eMTB+ 160 mm

Fox Float X Performance 160 mm

Ground Fiftyone Dia. 31.8 mm

Ground Fiftyone Dia. 31.8 mm 760/15 (S) 780/25 (M-XL)

Shimano XT RD-M8100 12-S

Shimano SLX SL-M7100

e*thirteen e*spec Plus 34T

Shimano SLX CS-M7100 10-51

Shimano Deore BR-M6120 203 mm Disc

Ghost Alpha 1 34.9 mm 125 (S) 150 (M) 170 (L/XL)

Fizik Terra Aidon

Acros Blocklock 135° AZX-582

SRAM UDH

WTB Wafel

Maxxis Minion DHF 3C MaxxTerra Exo+ 2.5 (S 27.5"; M-XL 29") //
Maxxis Minion DHR II 3C MaxxTerra Exo+ 2.6 (S 27.5"; M-XL 29")

WTB ST i30 //
WTB ST i30

Shimano HB-MT400-B 15x110 mm

Shimano FH-MT410-B 12x148 mm

Bosch Kiox 300

Bosch Performance Line CX

Bosch Power Tube 750 Wh

Bosch Charger 4 Ah

| GRÖSSE | ARTIKELNUMMER | LAUFRADGRÖSSE |
|--------|---------------|---------------|
| S | 31ER1019 | 27.5 |
| M | 31ER1020 | 29 |
| L | 31ER1021 | 29 |
| XL | 31ER1022 | 29 |



black / pearl deep red - glossy

SUPER FIT
by GHOST



E-RIOT AM ESSENTIAL

| | | |
|---|---|------------------------------|
| E-RIOT AL | SRAM PG-1210 11-50 | WTB ST i30 // WTB ST i30 |
| Rock Shox 35 Gold RL 160 mm | Tektro HD-M750 203 mm Disc | Shimano HB-MT400-B 15x110 mm |
| Rock Shox Super Deluxe Select+ RT 160 mm | Ghost Alpha 1 34.9 mm 125 (S) 150 (M) 170 (L/XL) | Shimano FH-MT400-B 12x148 mm |
| Ground Fiftyone Dia. 31.8 mm | Fizik Terra Aidon | Bosch Kiox 300 |
| Ground Fiftyone Dia. 31.8 mm 760/15 (S) 780/25 (M-XL) | Acros Blocklock 135° AZX-582 | Bosch Performance Line CX |
| SRAM SX Eagle 12-S | SRAM UDH | Bosch Power Tube 625 Wh |
| SRAM SX Eagle Single Click | WTB Wafel | Bosch Charger 4 Ah |
| e*thirteen e*spec Plus 34T | Maxxis Minion DHF 3C MaxxTerra Exo+ 2.5 (S 27.5"; M-XL 29") // Maxxis Minion DHR II 3C MaxxTerra Exo+ 2.6 (S 27.5"; M-XL 29") | |

| GRÖSSE | ARTIKELNUMMER | LAUFRADGRÖSSE |
|--------|---------------|---------------|
| S | 31ER1013 | 27.5 |
| M | 31ER1014 | 29 |
| L | 31ER1015 | 29 |
| XL | 31ER1016 | 29 |



black / gold - glossy



SUPER FIT
by GHOST



E-RIOT TRAIL ADVANCED

| | | |
|---|--|------------------------------|
| E-RIOT AL | SRAM PG-1230 11-50 | WTB ST i30 // WTB ST i30 |
| Rock Shox Revelation 150 mm | Tektro HD-M750 203 mm Disc | Shimano HB-MT400-B 15x110 mm |
| Rock Shox Super Deluxe Select+ RT 140 mm | Ghost Alpha 1 34.9 mm 125 (S) 150 (M) 170 (L/XL) | Shimano FH-MT400-B 12x148 mm |
| Ground Fiftyone Dia. 31.8 mm | Fizik Terra Aidon | Bosch Kiox 300 |
| Ground Fiftyone Dia. 31.8 mm 760/15 (S) 780/25 (M-XL) | Acros Blocklock 135° AZX-582 | Bosch Performance Line CX |
| SRAM NX Eagle 12-S | SRAM UDH | Bosch Power Tube 750 Wh |
| SRAM NX Eagle Single Click | WTB Wafel | Bosch Charger 4 Ah |
| e*thirteen e*spec Plus 34T | Schwalbe Nobby Nic Performance 2.6 (S 27,5"; M-XL 29") // Schwalbe Nobby Nic Performance 2.6 (S 27,5"; M-XL 29") | |

| GRÖSSE | ARTIKELNUMMER | LAUFRADGRÖSSE |
|--------|---------------|---------------|
| S | 31ER1007 | 27.5 |
| M | 31ER1008 | 29 |
| L | 31ER1009 | 29 |
| XL | 31ER1010 | 29 |



black / pearl dark grey - matt

SUPER FIT
by GHOST



E-RIOT TRAIL ESSENTIAL

| | | |
|---|--|------------------------------|
| E-RIOT AL | SRAM PG-1210 11-50 | WTB ST i30 // WTb ST i30 |
| Rock Shox 35 Silver TK Solo Air 150 mm | Shimano BR-MT420 203 mm Disc | Shimano HB-MT400-B 15x110 mm |
| Rock Shox Super Deluxe Select R 140 mm | Ghost Alpha 1 34.9 mm 125 (S) 150 (M) 170 (L/XL) | Shimano FH-MT400-B 12x148 mm |
| Ground Fiftyone Dia. 31.8 mm | Fizik Terra Aidon | Bosch Kiox 300 |
| Ground Fiftyone Dia. 31.8 mm 760/15 (S) 780/25 (M-XL) | Acros Blocklock 135° AZX-582 | Bosch Performance Line CX |
| SRAM SX Eagle 12-S | SRAM UDH | Bosch Power Tube 750 Wh |
| SRAM SX Eagle Single Click | WTB Wafel | Bosch Charger 4 Ah |
| e*thirteen e*spec Plus 34T | Schwalbe Nobby Nic Performance 2.6 (S 27,5"; M-XL 29") // Schwalbe Nobby Nic Performance 2.6 (S 27,5"; M-XL 29") | |

| GRÖSSE | ARTIKELNUMMER | LAUFRADGRÖSSE |
|--------|---------------|---------------|
| S | 31ER1001 | 27,5 |
| M | 31ER1002 | 29 |
| L | 31ER1003 | 29 |
| XL | 31ER1004 | 29 |



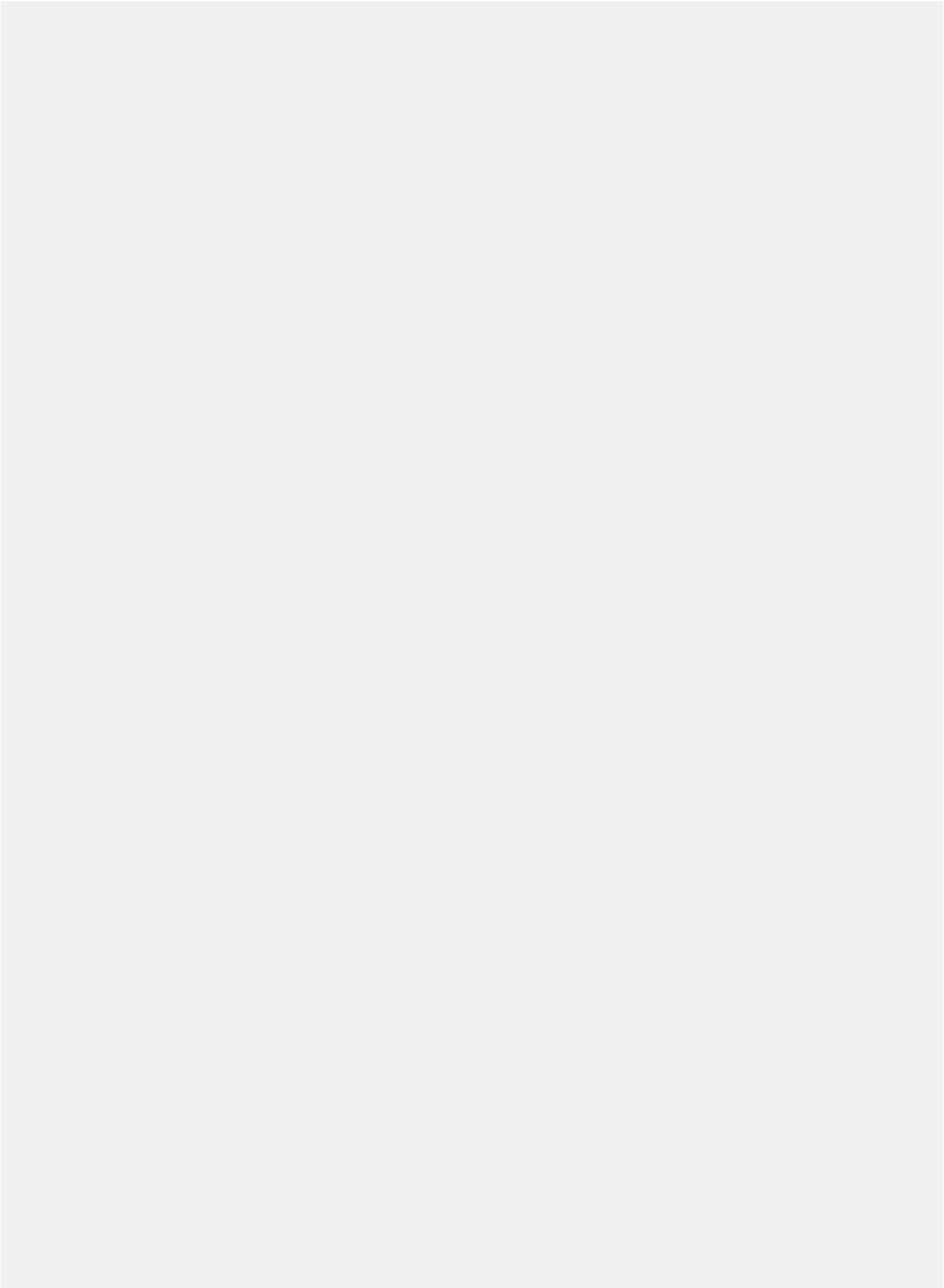

E-BIKES

PATH RIOT

E-TERU

E-RIOT

PATH ASKET

E-ASX

anthracite / black - glossy



E-ASX 160 UNIVERSAL

E-ASX AL

Rock Shox 35 Gold RL 160 mm

Rock Shox Deluxe Select R 160 mm

Ground Fiftyone Dia. 31.8 mm

Ground Fiftyone Dia. 31.8 mm 760/15 (S) 780/25 (M-XL)

SRAM NX Eagle 12-S

SRAM SX Eagle Single Click

e*thirteen e*spec Plus 34T

SRAM PG-1230 11-50

Shimano BR-MT520 203 mm Disc

Ghost Alpha 1 34.9 mm 125 (S) 150 (M) 170 (L/XL)

Selle Royal Vivo

Acros AZX-205

SRAM UDH

WTB Wafel

Maxxis Minion DHF 3C MaxxTerra Exo+ 2.5 29" //
Maxxis Minion DHR II 3C MaxxTerra Exo+ 2.6 27.5"

WTB ST i30 //
WTB ST i30

Shimano HB-MT400-B 15x110 mm

Shimano FH-MT400-B 12x148 mm

Bosch LED Remote

Bosch Performance Line CX

Bosch Power Tube 750 Wh

Bosch Charger 4 Ah

| GRÖSSE | ARTIKELNUMMER | LAUFRADGRÖSSE |
|--------|---------------|---------------|
| S | 31AS1013 | |
| M | 31AS1014 | |
| L | 31AS1015 | |
| XL | 31AS1016 | |



met. rusted red / black - glossy / matt



E-ASX 160 ESSENTIAL

E-ASX AL

Rock Shox 35 Silver TK Solo Air 160 mm

SR Suntour Raidon R 160 mm

Ground Fiftyone Dia. 31.8 mm

Ground Fiftyone Dia. 31.8 mm 760/15 (S) 780/25 (M-XL)

SRAM SX Eagle 12-S

SRAM SX Eagle Single Click

e*thirteen e*spec Plus 34T

SRAM PG-1210 11-50

Shimano BR-MT420 / 410 203 mm Disc

Ghost Alpha 1 34.9 mm 125 (S) 150 (M) 170 (L/XL)

Selle Royal Vivo

Acros AZX-205

SRAM UDH

WTB Wafel

Maxxis Minion DHF 3C MaxxTerra Exo+ 2.5 29" //
Maxxis Minion DHR II 3C MaxxTerra Exo+ 2.6 27.5"

WTB ST i30 //
WTB ST i30

Shimano HB-MT400-B 15x110 mm

Shimano FH-MT400-B 12x148 mm

Bosch LED Remote

Bosch Performance Line CX

Bosch Power Tube 625 Wh

Bosch Charger 4 Ah

| GRÖSSE | ARTIKELNUMMER | LAUFRADGRÖSSE |
|--------|---------------|---------------|
| S | 31AS1019 | |
| M | 31AS1020 | |
| L | 31AS1021 | |
| XL | 31AS1022 | |





met. anthrazit / light grey - glossy / matt



E-ASX 130 UNIVERSAL

E-ASX AL

SR Suntour XCR34 Air Boost LOR DS 130 mm

SR Suntour Raidon R 130 mm

Ground Fiftyone Dia. 31.8 mm

Ground Fiftyone Dia. 31.8 mm 760/15 (S) 780/25 (M-XL)

SRAM SX Eagle 12-S

SRAM SX Eagle Single Click

e*thirteen e*spec Plus 34T

SRAM PG-1210 11-50

Shimano BR-MT420 203 mm Disc

GHOST SP DC1 31.6 mm

Selle Royal Vivo

Acros AZX-205

SRAM UDH

WTB Wafel

Schwalbe Nobby Nic Performance 2.4 29" //
Schwalbe Nobby Nic Performance 2.6 27.5"

WTB ST i30 //
WTB ST i30

Shimano HB-MT400-B 15x110 mm

Shimano FH-MT400-B 12x148 mm

Bosch LED Remote

Bosch Performance Line CX

Bosch Power Tube 750 Wh

Bosch Charger 4 Ah

| GRÖSSE | ARTIKELNUMMER | LAUFRADGRÖSSE |
|--------|---------------|---------------|
| S | 31AS1007 | |
| M | 31AS1008 | |
| L | 31AS1009 | |
| XL | 31AS1010 | |



black / light kaki - matt



E-ASX 130 ESSENTIAL

| | | |
|---|---|------------------------------|
| E-ASX AL | Shimano Deore CS-M5100 11-51 | WTB ST i25 // WTB ST i30 |
| SR Suntour XCM34 Boost DS 130 mm | Shimano BR-MT420 / 410 203 mm Disc | Shimano HB-MT400-B 15x110 mm |
| SR Suntour Raidon R 130 mm | GHOST SP DC1 31.6 mm | Shimano FH-MT400-B 12x148 mm |
| Ground Fiftyone Dia. 31.8 mm | Selle Royal Vivo | Bosch LED Remote |
| Ground Fiftyone Dia. 31.8 mm 760/15 (S) 780/25 (M-XL) | Acros AZX-205 | Bosch Performance Line CX |
| Shimano Deore RD-M5100 11-S | SRAM UDH | Bosch Power Tube 625 Wh |
| Shimano Deore SL-M5100 | WTB Wafel | Bosch Charger 4 Ah |
| e*thirteen e*spec Plus 34T | Schwalbe Smart Sam 2.35 29" // Schwalbe Smart Sam 2.6 27.5" | |

| GRÖSSE | ARTIKELNUMMER | LAUFRADGRÖSSE |
|--------|---------------|---------------|
| S | 31AS1001 | |
| M | 31AS1002 | |
| L | 31AS1003 | |
| XL | 31AS1004 | |



E-BIKES

PATH RIOT

E-TERU

E-RIOT

PATH ASKET

E-ASX

light kaki / black - matt

SUPER FIT
by GHOST



E-TERU PRO

| | | |
|--|--|------------------------------|
| E-TERU AL | Shimano BR-MT420 203 mm Disc | Shimano HB-MT400-B 15x110 mm |
| Rock Shox 35 Silver TK Solo Air 120 mm | Ghost 34.9 mm | Shimano FH-MT510-B 12x148 mm |
| Ground Fiftyone Dia. 31.8 mm | Selle Royal Vivo | Bosch Kiox 300 |
| Ground Fiftyone Dia. 31.8 mm 720/20 (XS/S) 740/27 (M-XL) | Feimin H856 + Acros Blocklock | Bosch Performance Line CX |
| Shimano XT RD-M8100 12-S | SRAM UDH | Bosch Power Tube 750 Wh |
| Shimano SLX SL-M7100 | MTB Grip | Bosch Charger 4 Ah |
| Miranda Virage 38T | Schwalbe Smart Sam 2.35 (XS-S 27,5"; M-XL 29") // Schwalbe Smart Sam 2.35 (XS-S 27,5"; M-XL 29") | |
| Shimano SLX CS-M7100 10-51 | Schürmann Yak Disc 25 // Schürmann Yak Disc 25 | |

| GRÖSSE | ARTIKELNUMMER | LAUFRADGRÖSSE |
|--------|---------------|---------------|
| XS | 31ET1063 | 27,5 |
| S | 31ET1064 | 27,5 |
| M | 31ET1065 | 29 |
| L | 31ET1066 | 29 |
| XL | 31ET1067 | 29 |





black / pearl deep red - matt / glossy



SUPER FIT
by GHOST



E-TERU PRO

E-TERU AL

Rock Shox 35 Silver TK Solo Air 120 mm

Ground Fiftyone Dia. 31.8 mm

Ground Fiftyone Dia. 31.8 mm 720/20 (XS/S) 740/27 (M-XL)

Shimano XT RD-M8100 12-S

Shimano SLX SL-M7100

Miranda Virage 38T

Shimano SLX CS-M7100 10-51

Shimano BR-MT420 203 mm Disc

Ghost 34.9 mm

Selle Royal Vivo

Feimin H856 + Acros Blocklock

SRAM UDH

MTB Grip

Schwalbe Smart Sam 2.35 (XS-S 27,5"; M-XL 29") //
Schwalbe Smart Sam 2.35 (XS-S 27,5"; M-XL 29")

Schürmann Yak Disc 25 //
Schürmann Yak Disc 25

Shimano HB-MT400-B 15x110 mm

Shimano FH-MT510-B 12x148 mm

Bosch Kiox 300

Bosch Performance Line CX

Bosch Power Tube 750 Wh

Bosch Charger 4 Ah

GRÖSSE ARTIKELNUMMER LAUFRADGRÖSSE

| | | |
|----|----------|------|
| XS | 31ET1070 | 27.5 |
| S | 31ET1071 | 27.5 |
| M | 31ET1072 | 29 |
| L | 31ET1073 | 29 |
| XL | 31ET1074 | 29 |



black / pearl deep red - matt / glossy



SUPER FIT
by GHOST



E-TERU PRO EQ

- E-TERU AL
- Rock Shox 35 Silver TK Soto Air 100 mm
- Ground Fiftyone Adjustable Dia. 31.8 mm
- Ground Fiftyone Dia. 31.8 mm 720/20 (XS/S) 740/27 (M-XL)
- Shimano XT RD-M8100 12-S
- Shimano SLX SL-M7100
- Miranda Virage 38T
- Shimano SLX CS-M7100 10-51
- Shimano BR-MT420 203 mm Disc

- Ghost 34.9 mm
- Selle Royal Vivo
- Feimin FP-H858U + Acros Blocklock
- SRAM UDH
- MTB Grip
- Schwalbe Johnny Watts 2.35 // Schwalbe Johnny Watts 2.35
- Schürmann Yak Disc 25 // Schürmann Yak Disc 25
- Shimano HB-MT400-B 15x110 mm
- Shimano FH-MT510-B 12x148 mm

- Bosch Kiox 300
- Bosch Performance Line CX
- Bosch Power Tube 750 Wh
- Bosch Charger 4 Ah
- Carrier
- Fender
- Ursus Mooi
- Herrmans H-Black MR8
- Axa Juno E-Bike

| GRÖSSE | ARTIKELNUMMER | LAUFRADGRÖSSE |
|--------|---------------|---------------|
| XS | 31ET1077 | 27.5 |
| S | 31ET1078 | 27.5 |
| M | 31ET1079 | 27.5 |
| L | 31ET1080 | 27.5 |
| XL | 31ET1081 | 27.5 |



black / pearl deep red - matt / glossy

SUPER FIT
by GHOST



E-TERU PRO EQ LOW

| | | |
|--|--|---------------------------|
| E-TERU AL Low | Ghost 34.9 mm | Bosch Kiox 300 |
| Rock Shox 35 Silver TK Soto Air 100 mm | Selle Royal Vivo | Bosch Performance Line CX |
| Ground Fiftyone Adjustable Dia. 31.8 mm | Cane Creek Visco Set + Acros Blocklock | Bosch Power Tube 750 Wh |
| Ground Fiftyone Dia. 31.8 mm 720/20 (S) 740/27 (M-L) | SRAM UDH | Bosch Charger 4 Ah |
| Shimano XT RD-M8100 12-S | MTB Grip | Carrier |
| Shimano SLX SL-M7100 | Schwalbe Johnny Watts 2.35 // Schwalbe Johnny Watts 2.35 | Fender |
| Miranda Virage 38T | Schürmann Yak Disc 25 // Schürmann Yak Disc 25 | Ursus Mooi |
| Shimano SLX CS-M7100 10-51 | Shimano HB-MT400-B 15x110 mm | Herrmans H-Black MR8 |
| Shimano BR-MT420 203 mm Disc | Shimano FH-MT510-B 12x148 mm | Axa Juno E-Bike |

| GRÖSSE | ARTIKELNUMMER | LAUFRADGRÖSSE |
|--------|---------------|---------------|
| S | 31ET1084 | |
| M | 31ET1085 | |
| L | 31ET1086 | |



black / dark grey - matt / glossy



SUPER FIT
by GHOST



E-TERU ADVANCED

| | | |
|---|---|------------------------------|
| E-TERU AL | Shimano BR-MT420 203 mm Disc | Shimano HB-MT400-B 15x110 mm |
| SR Suntour XCR34 Air Boost LOR DS 120 mm | Ghost 34.9 mm | Shimano FH-MT400-B 12x148 mm |
| Ground Fiftyone Dia. 31.8 mm | Selle Royal Vivo | Bosch Kiox 300 |
| Ground Fiftyone Dia. 31.8 mm 720/20 (S) 740/27 (M-XL) | Feimin H856 + Acros Blocklock | Bosch Performance Line CX |
| Shimano XT Linkglide RD-M8130 11-S | SRAM UDH | Bosch Power Tube 750 Wh |
| Shimano XT Linkglide SL-M8130 | MTB Grip | Bosch Charger 4 Ah |
| Miranda Virage 38T | Schwalbe Smart Sam 2.35 (S 27,5"; M-XL 29") // Schwalbe Smart Sam 2.35 (S 27,5"; M-XL 29") | |
| Shimano XT Linkglide CS-LG600-11 11-50 | Schürmann Yak Disc 25 // Schürmann Yak Disc 25 | |

| GRÖSSE | ARTIKELNUMMER | LAUFRADGRÖSSE |
|--------|---------------|---------------|
| S | 31ET1037 | |
| M | 31ET1038 | |
| L | 31ET1039 | |
| XL | 31ET1040 | |





met. anthracite / met. gold yellow - glossy



SUPER FIT
by GHOST



E-TERU ADVANCED

E-TERU AL

SR Suntour XCR34 Air Boost LOR DS 120 mm

Ground Fiftyone Dia. 31.8 mm

Ground Fiftyone Dia. 31.8 mm 720/20 (S) 740/27 (M-XL)

Shimano XT Linkglide RD-M8130 11-S

Shimano XT Linkglide SL-M8130

Miranda Virage 38T

Shimano XT Linkglide CS-LG600-11 11-50

Shimano BR-MT420 203 mm Disc

Ghost 34.9 mm

Selle Royal Vivo

Feimin H856 + Acros Blocklock

SRAM UDH

MTB Grip

Schwalbe Smart Sam 2.35 (S 27,5"; M-XL 29") //
Schwalbe Smart Sam 2.35 (S 27,5"; M-XL 29")

Schürmann Yak Disc 25 //
Schürmann Yak Disc 25

Shimano HB-MT400-B 15x110 mm

Shimano FH-MT400-B 12x148 mm

Bosch Kiox 300

Bosch Performance Line CX

Bosch Power Tube 750 Wh

Bosch Charger 4 Ah

GRÖSSE ARTIKELNUMMER LAUFRADGRÖSSE

| | | |
|----|----------|------|
| S | 31ET1044 | 27.5 |
| M | 31ET1045 | 29 |
| L | 31ET1046 | 29 |
| XL | 31ET1047 | 29 |



black / dark grey - matt / glossy



SUPER FIT
by GHOST



E-TERU ADVANCED EQ

| |
|--|
| E-TERU AL |
| SR Suntour XCR34 Air Boost LOR DS 100 mm |
| Ground Fiftyone Adjustable Dia. 31.8 mm |
| Ground Fiftyone Dia. 31.8 mm 720/20 (S) 740/27 (M-XXL) |
| Shimano XT Linkglide RD-M8130 11-S |
| Shimano XT Linkglide SL-M8130 |
| Miranda Virage 38T |
| Shimano XT Linkglide CS-LG600-11 11-50 |
| Shimano BR-MT420 203 mm Disc |

| |
|--|
| Ghost 34.9 mm |
| Selle Royal Vivo |
| Feimin FP-H858U + Acros Blocklock |
| SRAM UDH |
| MTB Grip |
| Schwalbe Johnny Watts 2.35 // Schwalbe Johnny Watts 2.35 |
| Schürmann Yak Disc 25 // Schürmann Yak Disc 25 |
| Shimano HB-MT400-B 15x110 mm |
| Shimano FH-MT400-B 12x148 mm |

| |
|---------------------------|
| Bosch Kiox 300 |
| Bosch Performance Line CX |
| Bosch Power Tube 750 Wh |
| Bosch Charger 4 Ah |
| Carrier |
| Fender |
| Ursus Mooi |
| Herrmans H-Black MR4 |
| Axa Juno E-Bike |

| GRÖSSE | ARTIKELNUMMER | LAUFRADGRÖSSE |
|--------|---------------|---------------|
| S | 31ET1051 | 27.5 |
| M | 31ET1052 | 27.5 |
| L | 31ET1053 | 27.5 |
| XL | 31ET1054 | 27.5 |
| XXL | 31ET1055 | 27.5 |



black / dark grey - matt / glossy

SUPER FIT
by GHOST



E-TERU ADVANCED EQ LOW

| | | |
|--|--|---------------------------|
| E-TERU AL Low | Ghost 34,9 mm | Bosch Kiox 300 |
| SR Suntour XCR34 Air Boost LOR DS 100 mm | Selle Royal Vivo | Bosch Performance Line CX |
| Ground Fiftyone Adjustable Dia. 31.8 mm | Cane Creek Visco Set + Acros Blocklock | Bosch Power Tube 750 Wh |
| Ground Fiftyone Dia. 31.8 mm 720/20 (S) 740/27 (M-L) | SRAM UDH | Bosch Charger 4 Ah |
| Shimano XT Linkglide RD-M8130 11-S | MTB Grip | Carrier |
| Shimano XT Linkglide SL-M8130 | Schwalbe Johnny Watts 2.35 // Schwalbe Johnny Watts 2.35 | Fender |
| Miranda Virage 38T | Schürmann Yak Disc 25 // Schürmann Yak Disc 25 | Ursus Mooi |
| Shimano XT Linkglide CS-LG600-11 11-50 | Shimano HB-MT400-B 15x110 mm | Herrmans H-Black MR4 |
| Shimano BR-MT420 203 mm Disc | Shimano FH-MT400-B 12x148 mm | Axa Juno E-Bike |

| GRÖSSE | ARTIKELNUMMER | LAUFRADGRÖSSE |
|--------|---------------|---------------|
| S | 31ET1058 | 27.5 |
| M | 31ET1059 | 27.5 |
| L | 31ET1060 | 27.5 |



pearl warm grey / pearl dark blue - matt



SUPER FIT
by GHOST



E-TERU UNIVERSAL

| | | |
|--|--|------------------------------|
| E-TERU AL | Shimano BR-MT420 180 mm Disc | Shimano HB-MT400-B 15x110 mm |
| SR Suntour XCM34 Boost DS 120 mm | Ghost 34.9 mm | Shimano FH-MT400-B 12x148 mm |
| Ground Fiftyone Dia. 31.8 mm | Selle Royal Vivo | Bosch LED Remote |
| Ground Fiftyone Dia. 31.8 mm 720/20 (XS/S) 740/27 (M-XL) | Feimin H856 + Acros Blocklock | Bosch Performance Line CX |
| Shimano Deore RD-M4120-10-S | SRAM UDH | Bosch Power Tube 625 Wh |
| Shimano Deore SL-M4100 | MTB Grip | Bosch Charger 4 Ah |
| Miranda Virage 38T | Schwalbe Smart Sam 2.35 (XS-S 27,5"; M-XL 29") // Schwalbe Smart Sam 2.35 (XS-S 27,5"; M-XL 29") | |
| Shimano Deore CS-M4100 11-42 | Schürmann Yak Disc 25 // Schürmann Yak Disc 25 | |

| GRÖSSE | ARTIKELNUMMER | LAUFRADGRÖSSE |
|--------|---------------|---------------|
| XS | 31ET1018 | 27,5 |
| S | 31ET1019 | 27,5 |
| M | 31ET1020 | 29 |
| L | 31ET1021 | 29 |
| XL | 31ET1022 | 29 |



pearl warm grey / pearl dark blue - matt



E-TERU UNIVERSAL EQ

| | | |
|--|--|---------------------------|
| E-TERU AL | Ghost 34.9 mm | Bosch Kiox 300 |
| SR Suntour XCM34 Boost DS 100 mm | Selle Royal Vivo | Bosch Performance Line CX |
| Ground Fiftyone Adjustable Dia. 31.8 mm | Feimin FP-H858U + Acros Blocklock | Bosch Power Tube 625 Wh |
| Ground Fiftyone Dia. 31.8 mm 720/20 (XS/S) 740/27 (M-XL) | SRAM UDH | Bosch Charger 4 Ah |
| Shimano Deore RD-M4120-10-S | MTB Grip | Carrier |
| Shimano Deore SL-M4100 | Schwalbe Johnny Watts 2.35 // Schwalbe Johnny Watts 2.35 | Fender |
| Miranda Virage 38T | Schürmann Yak Disc 25 // Schürmann Yak Disc 25 | Ursus Mooi |
| Shimano Deore CS-M4100 11-42 | Shimano HB-MT400-B 15x110 mm | Herrmans H-Black MR4 |
| Shimano BR-MT420 180 mm Disc | Shimano FH-MT400-B 12x148 mm | Axa Juno E-Bike |

| GRÖSSE | ARTIKELNUMMER | LAUFRADGRÖSSE |
|--------|---------------|---------------|
| XS | 31ET1025 | 27.5 |
| S | 31ET1026 | 27.5 |
| M | 31ET1027 | 27.5 |
| L | 31ET1028 | 27.5 |
| XL | 31ET1029 | 27.5 |





pearl warm grey / pearl dark blue - matt



SUPER FIT
by GHOST



E-TERU UNIVERSAL EQ LOW

E-TERU AL Low

SR Suntour XCM34 Boost DS 100 mm

Ground Fiftyone Adjustable Dia. 31.8 mm

Ground Fiftyone Dia. 31.8 mm 720/20 (S) 740/27 (M-L)

Shimano Deore RD-M4120-10-S

Shimano Deore SL-M4100

Miranda Virage 38T

Shimano Deore CS-M4100 11-42

Shimano BR-MT420 180 mm Disc

Ghost 34.9 mm

Selle Royal Vivo

Cane Creek Visco Set + Acros Blocklock

SRAM UDH

MTB Grip

Schwalbe Johnny Watts 2.35 //
Schwalbe Johnny Watts 2.35

Schürmann Yak Disc 25 //
Schürmann Yak Disc 25

Shimano HB-MT400-B 15x110 mm

Shimano FH-MT400-B 12x148 mm

Bosch Kiox 300

Bosch Performance Line CX

Bosch Power Tube 625 Wh

Bosch Charger 4 Ah

Carrier

Fender

Ursus Mooi

Herrmans H-Black MR4

Axa Juno E-Bike

| GRÖSSE | ARTIKELNUMMER | LAUFRADGRÖSSE |
|--------|---------------|---------------|
| S | 31ET1032 | |
| M | 31ET1033 | |
| L | 31ET1034 | |



dark grey / met. light blue - matt

SUPER FIT
by GHOST



E-TERU ESSENTIAL

| | | |
|--|--|--|
| E-TERU AL | Shimano CS-HG-200-9 11-36 | Schürmann Yak Disc 25 // Schürmann Yak Disc 25 |
| SR Suntour XCM32 Boost DS 120 mm | Tektro HD-M275 180 mm Disc | Shimano HB-MT400-B 15x110 mm |
| Ground Fiftyone Dia. 31.8 mm | Ghost 31.6 mm | Shimano FH-MT400-B 12x148 mm |
| Ground Fiftyone Dia. 31.8 mm 700/0 (S) 720/20 (M) 740/27 (L) 760/40 (XL) | Selle Royal Vivo | Bosch LED Remote |
| Shimano Alivio RD-M3100 9-S | Feimin FP-868P | Bosch Performance Line |
| Shimano Alivio SL-M3100 | MTB Grip | Bosch Power Tube 500 Wh |
| Miranda Virage 38T | Schwalbe Smart Sam 2.35 (S 27,5"; M-XL 29") // Schwalbe Smart Sam 2.35 (S 27,5"; M-XL 29") | Bosch Charger 2 Ah |

| GRÖSSE | ARTIKELNUMMER | LAUFRADGRÖSSE |
|--------|---------------|---------------|
| S | 31ET1001 | |
| M | 31ET1002 | |
| L | 31ET1003 | |
| XL | 31ET1004 | |



dark grey / met. light blue - matt



E-TERU ESSENTIAL EQ

| | | |
|--|--|-------------------------|
| E-TERU AL | Ghost 31.6 mm | Bosch Performance Line |
| SR Suntour XCM32 Boost DS 80 mm | Selle Royal Vivo | Bosch Power Tube 500 Wh |
| Ground Fiftyone Dia. 31.8 mm | Feimin FP-868P | Bosch Charger 2 Ah |
| Ground Fiftyone Dia. 31.8 mm 700/0 (S) 720/20 (M) 740/27 (L) 760/40 (XL) | MTB Grip | Carrier |
| Shimano Alivio RD-M3100 9-S | Schwalbe Johnny Watts 2.35 // Schwalbe Johnny Watts 2.35 | Eurofender 65 mm |
| Shimano Alivio SL-M3100 | Schürmann Yak Disc 25 // Schürmann Yak Disc 25 | Ursus Mooi |
| Miranda Virage 38T | Shimano HB-MT400-B 15x110 mm | Trellock LS230 |
| Shimano CS-HG-200-9 11-36 | Shimano FH-MT400-B 12x148 mm | Axa Juno E-Bike |
| Tektro HD-M275 180 mm Disc | Bosch LED Remote | |

| GRÖSSE | ARTIKELNUMMER | LAUFRADGRÖSSE |
|--------|---------------|---------------|
| S | 31ET1007 | 27.5 |
| M | 31ET1008 | 27.5 |
| L | 31ET1009 | 27.5 |
| XL | 31ET1010 | 27.5 |



dark grey / met. light blue - matt



E-TERU ESSENTIAL EQ MID

| | | |
|--|--|-------------------------|
| E-TERU AL Mid | Ghost 31.6 mm | Bosch Performance Line |
| SR Suntour XCM32 Boost DS 80 mm | Selle Royal Vivo | Bosch Power Tube 500 Wh |
| Ground Fiftyone Dia. 31.8 mm | Feimin FP-868P | Bosch Charger 2 Ah |
| Ground Fiftyone Dia. 31.8 mm 700/0 (S) 720/20 (M) 740/27 (L) | MTB Grip | Carrier |
| Shimano Alivio RD-M3100 9-S | Schwalbe Johnny Watts 2.35 // Schwalbe Johnny Watts 2.35 | Eurofender 65 mm |
| Shimano Alivio SL-M3100 | Schürmann Yak Disc 25 // Schürmann Yak Disc 25 | Ursus Mooi |
| Miranda Virage 38T | Shimano HB-MT400-B 15x110 mm | Trellock LS230 |
| Shimano CS-HG-200-9 11-36 | Shimano FH-MT400-B 12x148 mm | Axa Juno E-Bike |
| Tektro HD-M275 180 mm Disc | Bosch LED Remote | |

| GRÖSSE | ARTIKELNUMMER | LAUFRADGRÖSSE |
|--------|---------------|---------------|
| S | 31ET1013 | |
| M | 31ET1014 | |
| L | 31ET1015 | |



dark grey / met. light blue - matt

SUPER FIT
by GHOST



E-TERU

| | | |
|------------------------------------|--|--|
| E-TERU AL Mid | Shimano CS-HG-200-9 11-36 | Schürmann Yak Disc 25 // Schürmann Yak Disc 25 |
| SR Suntour XCM32 Boost DS 120 mm | Tektro HD-M275 180 mm Disc | Shimano HB-MT400-B 15x110 mm |
| Ground Fiftyone Dia. 31.8 mm | Ghost 31.6 mm | Shimano FH-MT400-B 12x148 mm |
| Ground Fiftyone Dia. 31.8 mm 700/0 | Selle Royal Vivo | Bosch LED Remote |
| Shimano Alivio RD-M3100 9-S | Feimin FP-868P | Bosch Performance Line |
| Shimano Alivio SL-M3100 | MTB Grip | Bosch Power Tube 500 Wh |
| Miranda Virage 38T | Schwalbe Smart Sam 2.35 // Schwalbe Smart Sam 2.35 | Bosch Charger 2 Ah |

GRÖSSE ARTIKELNUMMER LAUFRADGRÖSSE

XS

31ET1089

27.5





E-BIKES

PATH RIOT

E-TERU

E-RIOT

PATH ASKET

E-ASX

met. rust red / black - glossy



SUPER FIT
by GHOST



PATH ASKET PRO

PATH ASKET LC

GHOST Carbon

Ground Fiftyone Dia. 31.8 mm

Gravel Bar RA120A 440 mm (S) 460 mm (M) 480 mm (L) 500 mm (XL)

SRAM GX Eagle AXS 12-S

SRAM Rival eTap AXS

Rotor 42T

SRAM XG 1295 10-52

SRAM Rival 160 mm Disc

Rock Shox Reverb AXS 31.6 mm 100 mm (S/M) 125 mm (L/XL)

Selle Royal SRX

Acros

GW UDH

Fizik Tempo Bondcrush

WTB Ranger 2.0 TCS Light/Fast // WTB Ranger 2.0 TCS Light/Fast

DT Swiss G540 24 mm // DT Swiss G540 24 mm

DT Swiss 350 Classic 12x100 mm

DT Swiss 350 Classic 12x148 mm

Fazua LED Hub

Fazua Ride 60

Fazua Energy 430 Wh

Fazua Charger 3A

GRÖSSE ARTIKELNUMMER LAUFRADGRÖSSE

| | | |
|----|----------|--|
| S | 31PA1007 | |
| M | 31PA1008 | |
| L | 31PA1009 | |
| XL | 31PA1010 | |



carbon / pearl warm grey - glossy



SUPER FIT
by GHOST



PATH ASKET ADVANCED

- PATH ASKET LC
- Rock Shox Rudy Base 40 mm
- Ground Fiftyone Dia. 31.8 mm
- Gravel Bar RA120A 440 mm (S) 460 mm (M) 480 mm (L) 500 mm (XL)
- Shimano GRX RD-RX812 11-S
- Shimano GRX ST-RX810
- Rotor 42T
- Shimano XT CS-M8000 11-42

- Shimano GRX BR-RX810 160 mm Disc
- JD YSP15DL 31.6 mm 100 mm (S/M) 125 mm (L/XL)
- Selle Royal SRX
- Acros AZX-203
- GW UDH
- Fizik Tempo Bondcrush
- Maxxis Ravenger Exo TR 40-622 // Maxxis Ravenger Exo TR 40-622
- WTB ST i25 // WTB ST i25

- Shimano HB-RS470 12x100 mm
- Shimano FH-MT400-B 12x148 mm
- Fazua LED Hub
- Fazua Ride 60
- Fazua Energy 430 Wh
- Fazua Charger 3A

| GRÖSSE | ARTIKELNUMMER | LAUFRADGRÖSSE |
|--------|---------------|---------------|
| S | 31PA1001 | 29 |
| M | 31PA1002 | 29 |
| L | 31PA1003 | 29 |
| XL | 31PA1004 | 29 |



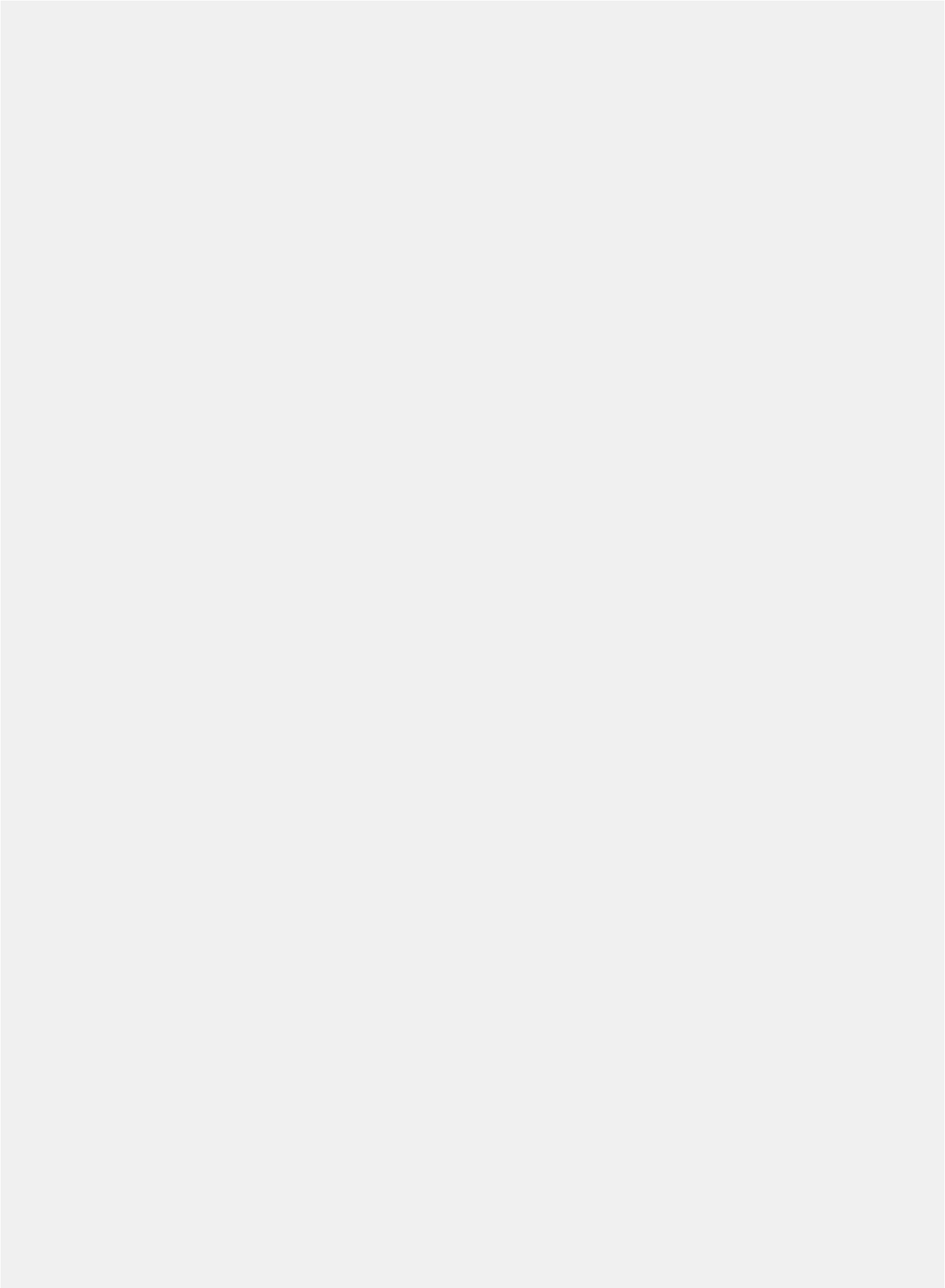

P&A

| BIKEPARTS

GND51 FREESTYLE PEDAL



DE DETAILS

- ▶ Einteiliger Aluminiumkörper
- ▶ CroMo-Achsversiegelt
- ▶ Kugellager
- ▶ 20 Pins pro Pedal
- ▶ Mit Reflektor

EN DETAILS

- ▶ One-Piece Alloy Body
- ▶ CroMo-Axel-Sealed
- ▶ Ball Bearing
- ▶ 20 Pins per Pedal
- ▶ With Reflector

| DESCRIPTION | COLOR | ART.-NR. |
|--------------------------------|-------------|----------|
| MTB/ATB FREESTYLE PEDAL PD-M26 | Black Shiny | AM0001 |

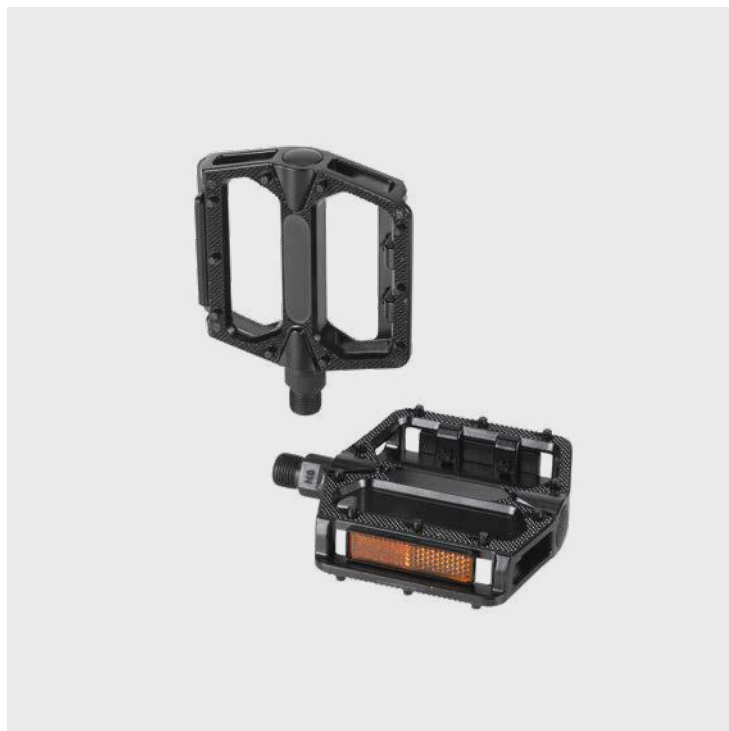

GND51 FLAT PEDAL POLY



DE DETAILS

- ▶ Einteiliger Polycarbonatkörper
- ▶ CroMo-Achse
- ▶ Gleitlager
- ▶ 20 Pins pro Pedal

EN DETAILS

- ▶ One-Pice-Polycarbonate Body
- ▶ CroMo-Axel
- ▶ Sleeve Bearing
- ▶ 20 Pins per Pedal

| DESCRIPTION | COLOR | ART.-NR. |
|---------------------------|------------|----------|
| MTB/ATB FLAT PEDAL PD-M23 | Black Flat | AM0002 |



GND51 FLAT PEDAL ALLOY



DE DETAILS

- ▶ CRO-MO-Achse
- ▶ Abgedichtete Lager
- ▶ Perfekter Grip
- ▶ Austauschbare Pins
- ▶ Sehr leicht, 300g

EN DETAILS

- ▶ CRO-MO Axle
- ▶ Sealed bearings
- ▶ Perfect grip
- ▶ Replaceable pins
- ▶ Lightweight, 300g

| DESCRIPTION | COLOR | ART.-NR. |
|---------------------------|-------------|----------|
| MTB/ATB FLAT PEDAL PD-M20 | Black Shiny | AM0003 |



GND51 BOTTLE CAGES



DE DETAILS

- ▶ Leicht
- ▶ Einfach zu benutzen
- ▶ Passt perfekt auf dein GHOST-Bike

EN DETAILS

- ▶ Lightweight
- ▶ Easy to use
- ▶ Fits your GHOST bike perfectly
- ▶ Standard Bottle Mount Size

| DESCRIPTION | COLOR | ART.-NR. |
|-----------------------------|-------------|----------|
| Bottle-Cage BC-A03 ① | Black Shiny | AM0004 |
| Bottle-Cage BC-K05 ② | Black Shiny | AM0005 |
| Bottle-Cage RACEBY BC-C04 ③ | Black Flat | AM0006 |

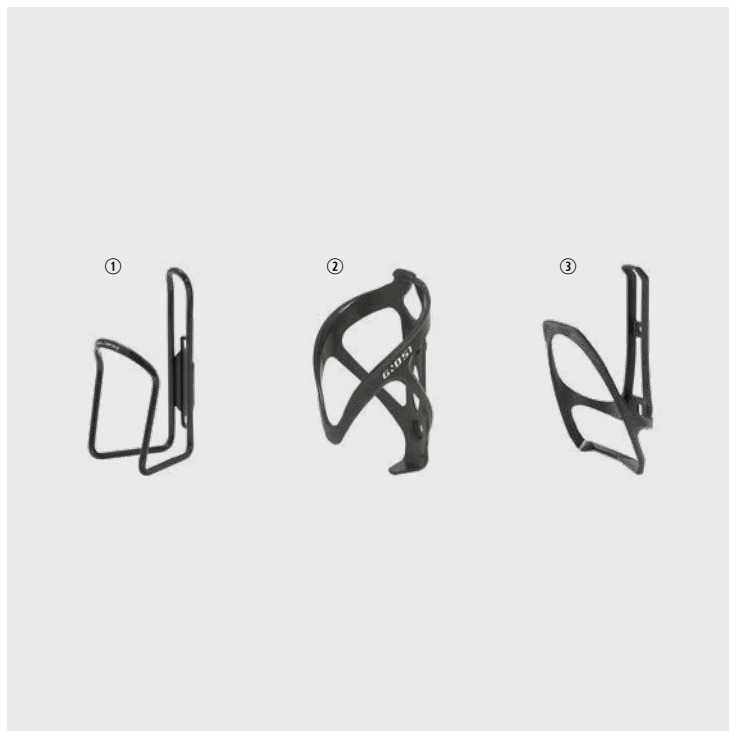

GND51 MULTITOOl SUPER B



Grey

DE DETAILS

- ▶ 9-teilig
- ▶ Torx- und Inbusschlüssel
- ▶ GND51-Branding

EN DETAILS

- ▶ 9 pieces
- ▶ Torx and Allen wrench
- ▶ GND51 branding

| DESCRIPTION | COLOR | ART.-NR. |
|-------------------------|-------|----------|
| GND51 Multitool Super B | Grey | AM0016 |



GND51 MULTITOOl WINRIDE



Black Flat

DE DETAILS

- ▶ 12-teilig
- ▶ Torx- und Inbusschlüssel
- ▶ GND51-Branding

EN DETAILS

- ▶ 12 pieces
- ▶ Torx and Allen wrench
- ▶ GND51 branding

| DESCRIPTION | COLOR | ART.-NR. |
|-------------------------|------------|----------|
| GND51 Multitool Winride | Black Flat | AM0017 |



KICKSTANDS



DE DETAILS

- ▶ Passt perfekt zu deinem GHOST-Bike
- ▶ Aluminium Befestigung
- ▶ Einstellbare Endkappe aus Kunststoff
- ▶ Leicht zu montieren

EN DETAILS

- ▶ Matches your GHOST bike perfectly
- ▶ Alloy Mounting Part
- ▶ Adjustable Plastic End Cap
- ▶ Easy to mount

| DESCRIPTION | COLOR | ART.-NR. |
|---|---------------|----------|
| Ursus M001 R90 Rear-18mm // 26-29" E-Teru, E-Square, E-RIOT, NIRVANA, RIOT | ① Black Shiny | AM0010 |
| Ursus M001 R90 Rear-40mm // 26-29" Square Urban | ② Black Shiny | AM0012 |
| Ursus M001 R90 Rear-40mm // 26-29" Kato, Lanao | ③ Black Shiny | AM0013 |
| Ursus Easy 92 Center-Mid // 26-29" Square Cross, Square Trekking | ④ Black Shiny | AM0015 |
| Nuvo-18mm // 20-28" Kato 20"-24", Lanao 20"-24" | ⑤ Black Shiny | AM0049 |

Ständer- und Adapterübersicht auf S.215
Kickstand and adapter overview on p.215



KICKSTAND ADAPTER



DE DETAILS

- ▶ KSA18 Montagemöglichkeit
- ▶ Aluminium
- ▶ Inklusive Schrauben

EN DETAILS

- ▶ KSA18 Mounting Option
- ▶ Alloy
- ▶ Including Screws

| DESCRIPTION | COLOR | ART.-NR. |
|--|--------------|----------|
| Kickstand Adapter (E-TERU, E-TERU LOW, KATO FS, RIOT YOUTH) | ① Black Flat | GA0128 |
| Kickstand Adapter (E-RIOT AL / CF, RIOT AL) | ② Black Flat | FROT0206 |
| Kickstand Adapter (NIRVANA TOUR, NIRVANA TRAIL) | ③ Black Flat | FROT0067 |

Ständer- und Adapterübersicht auf S.215
Kickstand and adapter overview on p.215



GND51 P.U.B. BOTTLE

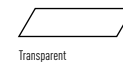

Transparent

DE DETAILS

- ▶ Fidlock-Magnetsystem für einfache Handhabung (P.U.B. = pick-up-bottle)
- ▶ Kein klassischer Flaschenhalter mehr nötig

EN DETAILS

- ▶ Fidlock magnet retaining system for easy handling (P.U.B. = pick-up-bottle)
- ▶ No need for normal bottle cage anymore

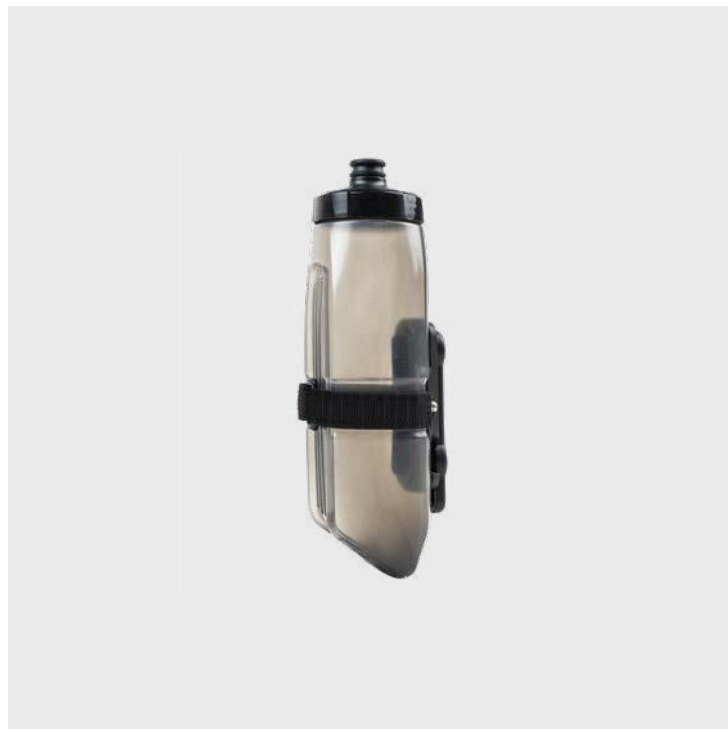

| DESCRIPTION | COLOR | ART.-NR. |
|-----------------------------------|-------------|----------|
| GND51 P.u.B Fid Lock Bottle 700ml | Transparent | AM0025 |

GND51 GRIPS SUPERFIT



Black Flat

DE DETAILS

- ▶ Aluminiumklemmung
- ▶ Länge 130mm / Durchmesser 32 mm
- ▶ Geschlossene Enden
- ▶ SuperFit Markierungen Pro

EN DETAILS

- ▶ Alloy Clamp
- ▶ 130mm / Dia. 30mm
- ▶ Closed End
- ▶ SuperFit Marking Pro



| DESCRIPTION | COLOR | ART.-NR. |
|--------------------------------------|------------|----------|
| Grip-Production Privee-GND51 OE CR35 | Black Flat | AM0009 |

GND51 ADJUSTABLE SADDLE



Black Flat

DE DETAILS

- ▶ GHOST-Design und -Branding
- ▶ Perfekt auf unsere Bikes abgestimmt
- ▶ Hochwertige Materialien und langlebige Qualität
- ▶ Unisex Sattel in Größe S und M

EN DETAILS

- ▶ GHOST-Design and -Branding
- ▶ Matches your GHOST bike perfectly
- ▶ High quality materials, durable quality
- ▶ Unisex saddle in adjustable Size S and M

| DESCRIPTION | COLOR | ART.-NR. |
|--|------------|----------|
| Selle Italia Adjustable Tour Base Material: Aluminium / Alloy | Black Flat | AM0018 |
| Selle Italia Adjustable XC Pro Material: Titan / titan | Black Flat | AM0020 |

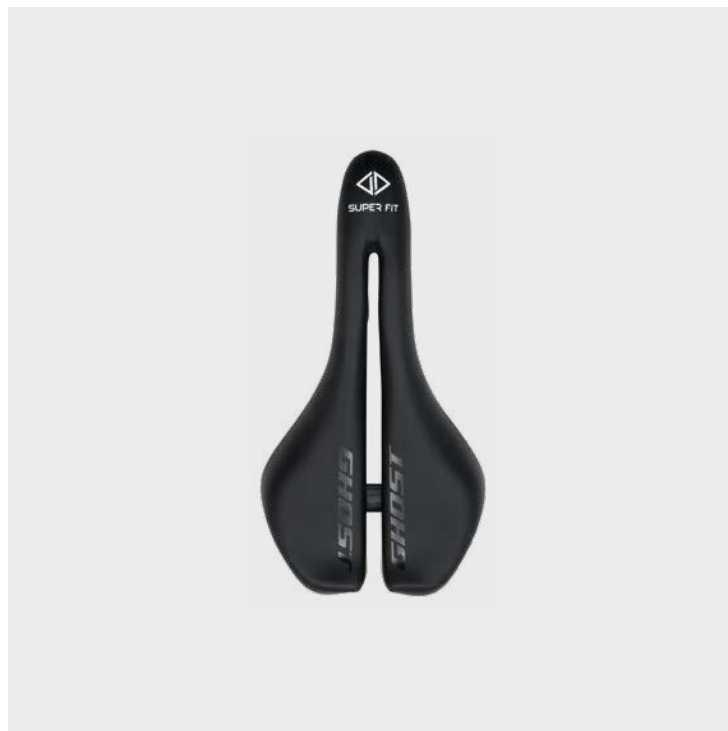

GND51 FRONT MUD FLAP



Black Flat

DE DETAILS

- ▶ Extra hergestellt für perfekte Steifig- und Dauerhaltbarkeit
- ▶ Hergestellt aus recyclefähigem Polypropylen (PP)
- ▶ Passende Laufradgrößen - 20", 24", 26", 26"+, 27.5", 27.5"+, 29", 29"+
- ▶ Mit 33g ist der Fender ein echtes Leichtgewicht und für alle Formen des Raceinsatzes empfehlenswert

EN DETAILS

- ▶ Extra strong for perfect stiffness and durability, made of recyclable polypropylene
- ▶ Wheelsize - 20", 24", 26", 26"+, 27.5", 27.5"+, 29", 29"+
- ▶ With 33g the fender is a real lightweight and recommended for all forms of racing use

| DESCRIPTION | COLOR | ART.-NR. |
|----------------------|------------|----------|
| GND51 Front Mud Flap | Black Flat | FEF0017 |



P&A

GND51 NIRVANA FENDER KIT



DE DETAILS

- ▶ Das Schutzblechset das zu deinem NIRVANA Bike passt
- ▶ Fünf Befestigungsstrips

EN DETAILS

- ▶ The fender kit that fits your NIRVANA Bike.
- ▶ Five fastening strips

| DESCRIPTION | COLOR | ART.-NR. |
|--------------------------|------------|----------|
| GND51 NIRVANA Fender Kit | Black Flat | AM0027 |

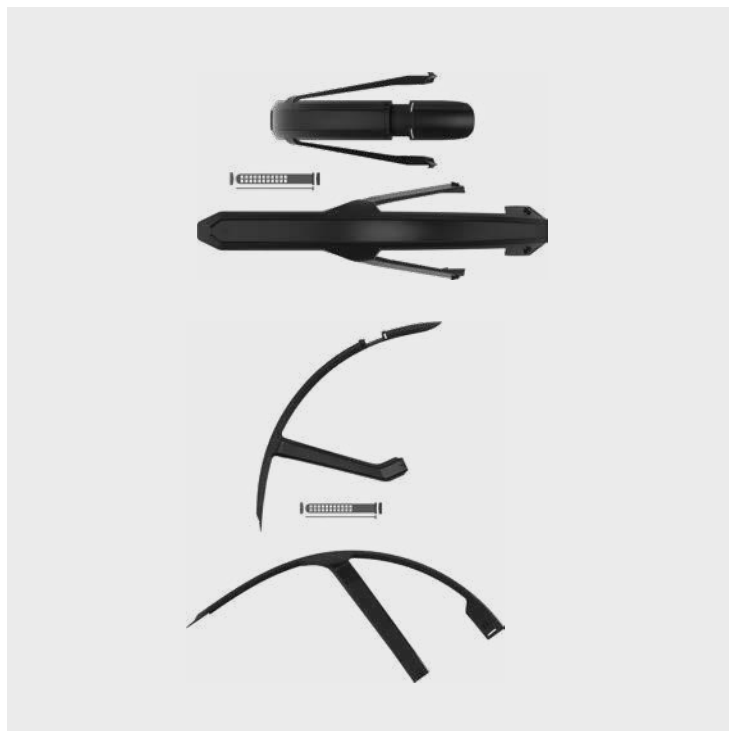

GND51 STARNUT SET



DE DETAILS

- ▶ Die Einschlagkralle für den Gabelschaft
- ▶ Hilft den Steuersatz zu zentrieren

EN DETAILS

- ▶ The starnut for the steerer tube
- ▶ Helps to center the headset

| DESCRIPTION | COLOR | ART.-NR. |
|-------------------|-------------|----------|
| GND51 Starnut Set | Black Shiny | AM0053 |



GND51 HEADSETS

DE DETAILS

- ▶ Kompletter Steuersatz
- ▶ In verschiedenen Größen erhältlich

DE DETAILS

- ▶ Kompletter Steuersatz
- ▶ In verschiedenen Größen erhältlich

| DESCRIPTION | COLOR | ART.-NR. |
|---|---------------|----------|
| GND51 Headset Kidbike Fork Steerer 1-1/8 / Straight Headtube 44/44 | ① Black Shiny | AM0050 |
| GND51 Reducer Headset Fork Steerer 1-1/8 / Tapered Headtube 44/56 | ② Black Shiny | AM0051 |
| GND51 Tapered Headset Fork Steerer 1-1/8 to 1.5 / Tapered Headtube 44/56 or 56/62 | ③ Black Shiny | AM0052 |



GND51 CONUS SPACER



DE DETAILS

- ▶ Material: Aluminium

EN DETAILS

- ▶ Material: aluminum

| DESCRIPTION | COLOR | ART.-NR. |
|--------------------|------------|----------|
| GND51 Conus Spacer | Black Flat | AM0054 |
| GND51 Spacer 10mm | Black Flat | AM0055 |
| GND51 Spacer 5mm | Black Flat | AM0056 |



ACROS HEADSET TOOL



DE DETAILS

- ▶ Für die meisten Steuersätze geeignet
- ▶ Geringes Gewicht und kompakte Abmessungen, perfekt für unterwegs
- ▶ Einpressadapter aus faserverstärktem Kunststoff schonen den Fahrradrahmen

EN DETAILS

- ▶ Suitable for most headset
- ▶ Light weight and compact dimensions, perfect for traveling
- ▶ Press-fit adapters made of fiber-reinforced plastic protect the bike frame



| DESCRIPTION | COLOR | ART.-NR. |
|--------------------|-------------|----------|
| Acros Headset Tool | Black Shiny | AM0075 |

ACROS UPPER BEARING SET



DE DETAILS

- ▶ Nur **oberer** Teil des Steuersatzes
- ▶ **Oberer** Lagerschale + Lager + Aheadkappe

EN DETAILS

- ▶ Only **upper** part of headset
- ▶ **Upper** bearing shell + bearing + ahead cap



| DESCRIPTION | COLOR | ART.-NR. |
|---|---------------|----------|
| Acros Upper Bearing Set | ① Black Shiny | AM0072 |
| Acros Upper Bearing Set Block Lock 135° | ② Black Shiny | AM0073 |

ACROS LOWER BEARING SET



DE DETAILS

- ▶ Nur **unterer** Teil des Steuersatzes
- ▶ **Untere** Lagerschale + Lager

EN DETAILS

- ▶ Only **lower** part of headset
- ▶ **Lower** bearing shell + bearing

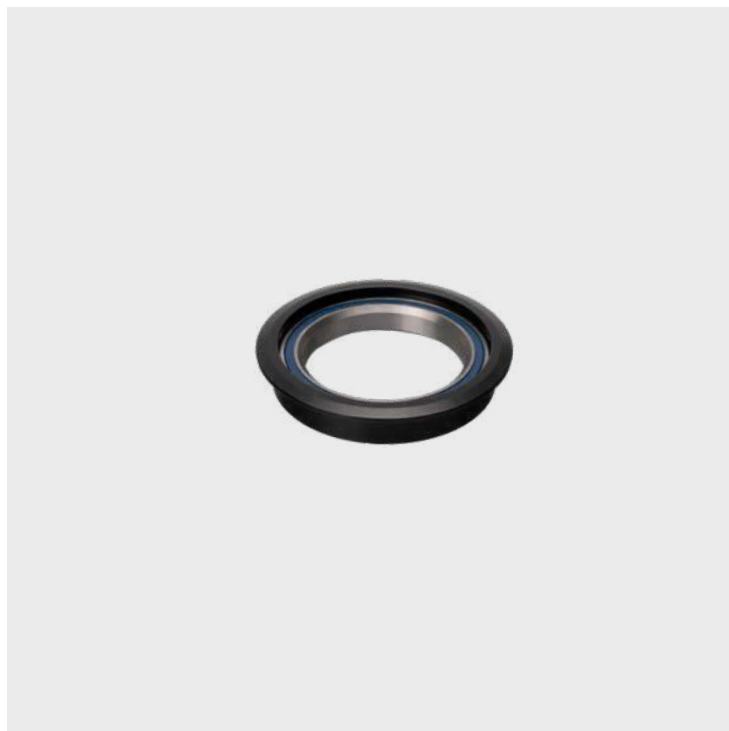

| DESCRIPTION | COLOR | ART.-NR. |
|-------------------------|-------------|----------|
| Acros Lower Bearing Set | Black Shiny | AM0074 |

GND51 VALVE ADAPTER



DE DETAILS

- ▶ Ventiladapter mit praktischem Schlüsselring
- ▶ Von AV (Pumpe) auf DV / SV (Ventil)

EN DETAILS

- ▶ Valve adapter with practical key ring
- ▶ From AV (pump) to DV / SV (valve)



| DESCRIPTION | COLOR | ART.-NR. |
|---------------|-----------------|----------|
| Valve Adapter | Black/Red Shiny | AM0029 |

GND51 CARTRIDGE PUMP

Silver / Black

DE DETAILS

- ▶ Kartuschenpumpe für DV / SV / AV
- ▶ Aluminium Pumpenkopf
- ▶ Inklusive 16 g Kartusche und zwei Ersatzkartuschen

EN DETAILS

- ▶ Cartridge mini pump for DV / SV / AV
- ▶ Aluminium pump head
- ▶ Incl. 16g cartridge and two spare cartridges



| DESCRIPTION | COLOR | ART.-NR. |
|----------------|----------------|----------|
| CARTRIDGE PUMP | Silver / Black | AM0031 |

GND51 SUSPENSION PUMP

Silver / Black

DE DETAILS

- ▶ Federgabelpumpe bis 28 bar/400 psi für AV
- ▶ Ventilknopf mit Bleed-Funktion
- ▶ Kein Druckverlust durch Sicherheitsventil

EN DETAILS

- ▶ Suspension fork pump up to 28 bar/400 psi for AV
- ▶ Valve head with bleed function
- ▶ Safety valve prevents drop in pressure

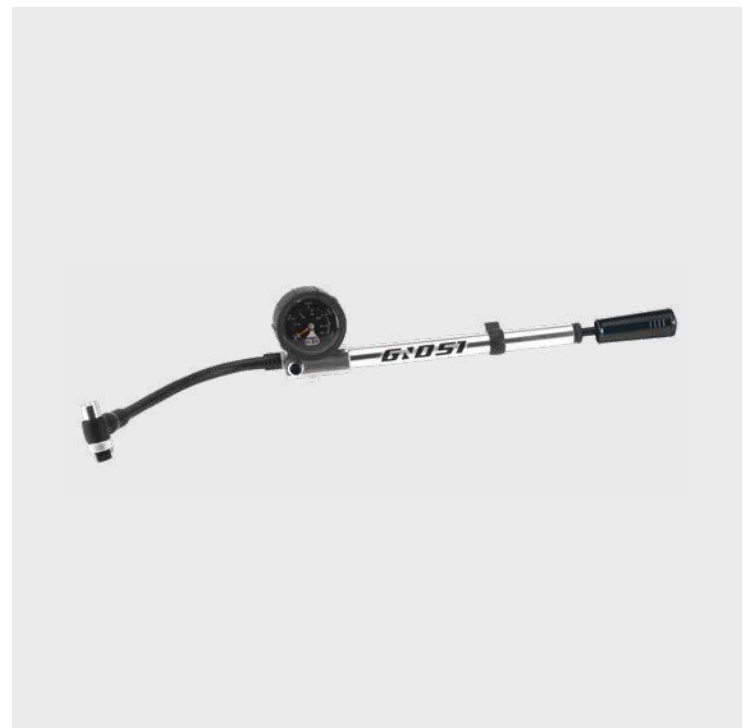

| DESCRIPTION | COLOR | ART.-NR. |
|-----------------|----------------|----------|
| SUSPENSION PUMP | Silver / Black | AM0032 |

GND51 SUPERFIT STEM



DE DETAILS

- ▶ GND 51 Vorbau 31,8 mm
- ▶ Rise 6 Grad

EN DETAILS

- ▶ GND 51 Stem 31.8 mm
- ▶ Rise 6 degrees



| DESCRIPTION | COLOR | ART.-NR. |
|---------------------|------------|----------|
| GND51 Superfit Stem | Black Flat | AM0071 |

GND51 SUPERFIT BAR



DE DETAILS

- ▶ Robuster Lenker aus Aluminium
- ▶ Klemmung 31,8 mm

EN DETAILS

- ▶ Aluminum handlebar
- ▶ Clamp: 31.8mm

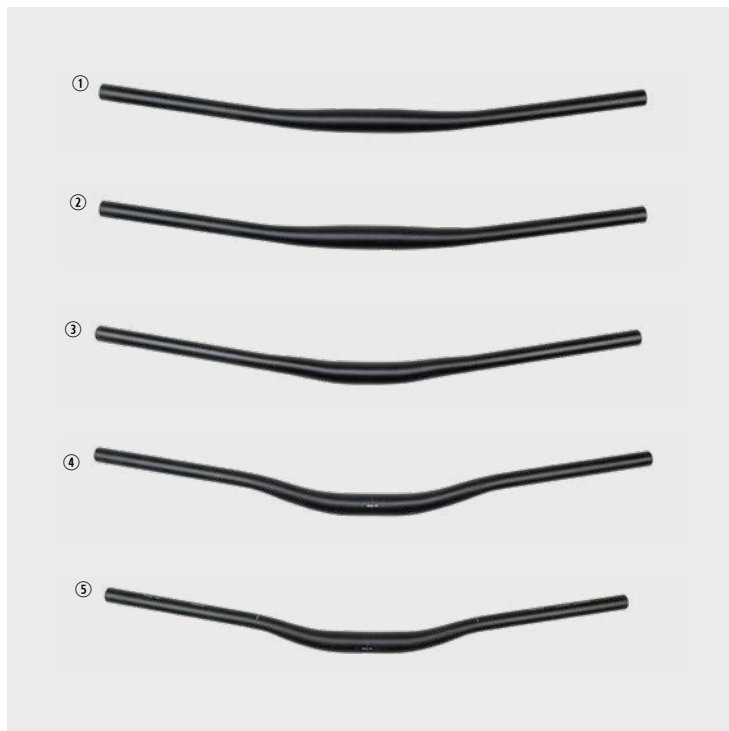

| DESCRIPTION | COLOR | ART.-NR. |
|---|--------------|----------|
| GND51 Superfit Bar 31,8mm / 760mm / 8° / Rise 0mm | ① Black Flat | AM0066 |
| GND51 Superfit Bar 31,8mm / 780mm / 8° / Rise 15mm | ② Black Flat | AM0067 |
| GND51 Superfit Bar 31,8mm / 720mm / 8° / Rise 20mm | ③ Black Flat | AM0068 |
| GND51 Superfit Bar 31,8mm / 740mm / 9° / Rise 27mm | ④ Black Flat | AM0069 |
| GND51 Superfit Bar 31,8mm / 780mm / 8° / Rise 40mm | ⑤ Black Flat | AM0070 |

GND SEATPOST 31.6



DE DETAILS

- ▶ Leichte Aluminiumsattelstütze
- ▶ Verstellerschraube für die individuelle Anpassung des Sitzwinkels
- ▶ GND51 Branding
- ▶ 31,6 mm Durchmesser

EN DETAILS

- ▶ Lightweight aluminium seatpost
- ▶ Individual seating angle adjustment with screw
- ▶ GND51-Branding
- ▶ 31.6 mm diameter

| DESCRIPTION | COLOR | ART.-NR. |
|---------------------------------|--------------|----------|
| GND51 SEATPOST / 31,6mm x 350mm | ① Black Flat | AM0033 |
| GND51 SEATPOST / 31,6mm x 400mm | ② Black Flat | AM0034 |



GND SEATPOST 34.9



DE DETAILS

- ▶ Leichte Aluminiumsattelstütze
- ▶ 34,9 mm Durchmesser
- ▶ Verstellerschraube für die individuelle Anpassung des Sitzwinkels
- ▶ GND51 Branding

EN DETAILS

- ▶ Lightweight aluminium seatpost
- ▶ 34.9 mm diameter
- ▶ Individual seating angle adjustment with screw
- ▶ GND51-Branding

| DESCRIPTION | COLOR | ART.-NR. |
|--|--------------|----------|
| GND51 SEATPOST 34,9mm x 400mm / Offset 25mm | ① Black Flat | AM0035 |
| GND51 SEATPOST 34,9mm x 450mm / Offset 25mm | ② Black Flat | AM0036 |



GND51 DROPPER SEATPOST 31.6



DE DETAILS

- ▶ Teleskopsattelstütze
- ▶ 31,6 mm Durchmesser
- ▶ Aluminiumhebel
- ▶ Höhenverstellbarkeit: 100 / 125 / 150 mm
- ▶ Offset: 0 mm

EN DETAILS

- ▶ Telescopic seatpost
- ▶ 31.6 mm diameter
- ▶ Alloy remote lever
- ▶ Travel: 100 / 125 / 150 mm
- ▶ Offset: 0 mm

| DESCRIPTION | COLOR | ART.-NR. |
|--|------------|----------|
| GND51 DROPPER SEATPOST 31,6mm / 100mm Travel / 0mm Offset | Black Flat | AM0037 |
| GND51 DROPPER SEATPOST 31,6mm / 125mm Travel / 0mm Offset | Black Flat | AM0038 |
| GND51 DROPPER SEATPOST 31,6mm / 150mm Travel / 0mm Offset | Black Flat | AM0039 |

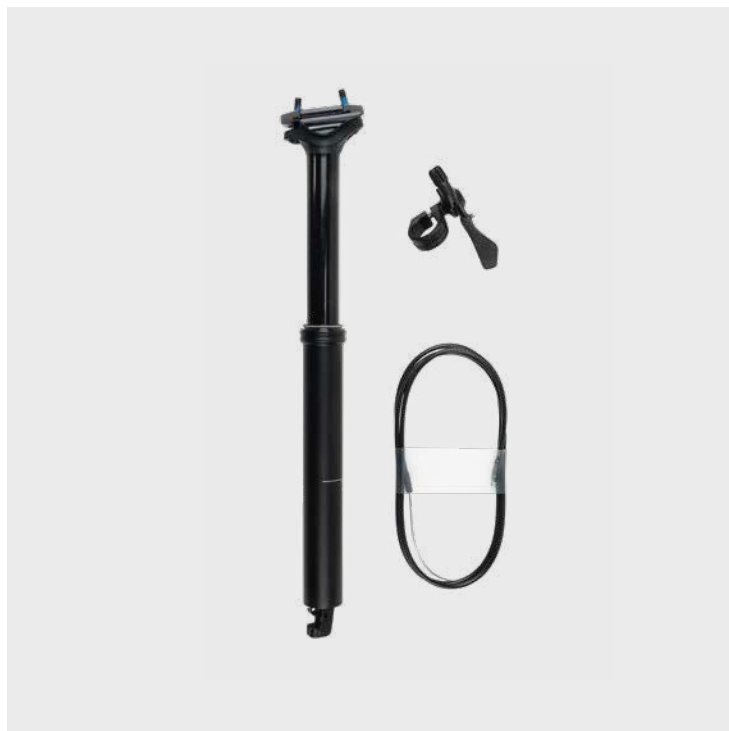

GND51 DROPPER SEATPOST 34.9



DE DETAILS

- ▶ Teleskopsattelstütze
- ▶ 34,9 mm Durchmesser
- ▶ Aluminiumhebel
- ▶ Höhenverstellbarkeit: 125 / 150 / 170 mm
- ▶ Offset: 25 mm

EN DETAILS

- ▶ Telescopic seatpost
- ▶ 34.9 mm diameter
- ▶ Alloy remote lever
- ▶ Travel: 125 / 150 / 170 mm
- ▶ Offset: 25 mm

| DESCRIPTION | COLOR | ART.-NR. |
|---|------------|----------|
| GND51 DROPPER SEATPOST 31,6mm / 125mm Travel / 25mm Offset | Black Flat | AM0040 |
| GND51 DROPPER SEATPOST 31,6mm / 150mm Travel / 25mm Offset | Black Flat | AM0041 |
| GND51 DROPPER SEATPOST 31,6mm / 170mm Travel / 25mm Offset | Black Flat | AM0042 |



GND51 DROPPER REMOTE LEVER



DE DETAILS

- ▶ Aluminiumhebel

EN DETAILS

- ▶ Alloy remote lever

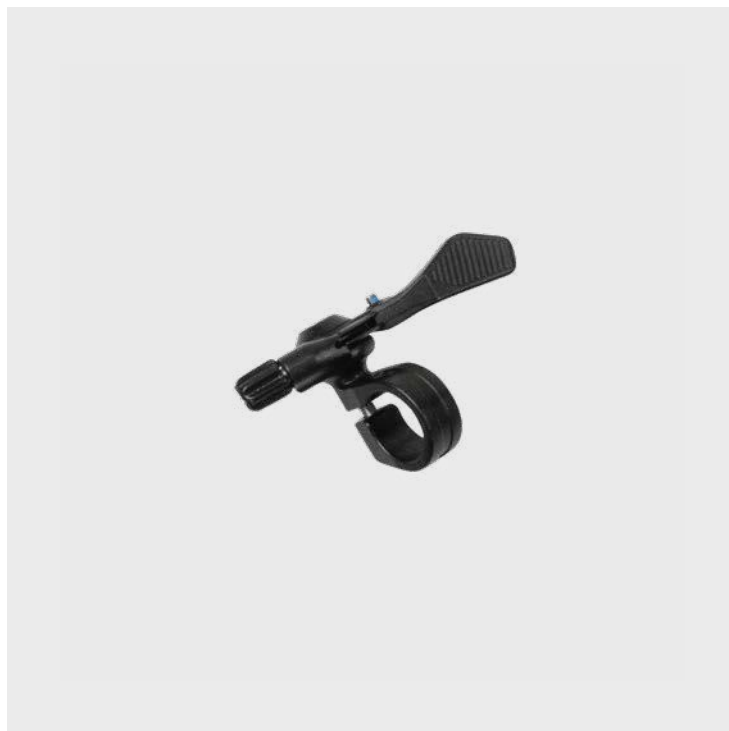

| DESCRIPTION | COLOR | ART.-NR. |
|----------------------------|------------|----------|
| GND51 DROPPER REMOTE LEVER | Black Flat | AM0043 |

GND51 SEAT CLAMP



DE DETAILS

- ▶ Die Sattelklemmen für deine GHOST Bikes
- ▶ Die Sattelklemmen passen zu allen 31,6 mm und 34,9 mm Sattelstützen

EN DETAILS

- ▶ The seat clamps for your GHOST bikes
- ▶ The seat clamps fit all 31.6 mm and 34.9 mm seat posts



| DESCRIPTION | COLOR | ART.-NR. |
|---|--------------|----------|
| GND51 SEAT CLAMP 34,9mm / height 12mm | ① Black Flat | AM0045 |
| GND51 SEAT CLAMP 38,0mm / height 15mm | ② Black Flat | AM0044 |
| GND51 SEAT CLAMP 38,0mm with Carrier Mount | ③ Black Flat | AM0046 |

GND51 CARRIER ADAPTER SET



Black Flat

DE DETAILS

- ▶ Der Gepäckträgeradapter für dein NIRVANA Bike
- ▶ So kannst du jedes NIRVANA Bike mit einem Gepäckträger ausstatten
- ▶ Set mit Schrauben

EN DETAILS

- ▶ The carrier adapter for your NIRVANA bike
- ▶ You can equip every NIRVANA bike with a carrier
- ▶ Set with screws



| DESCRIPTION | COLOR | ART.-NR. |
|---------------------------|------------|----------|
| GND51 Carrier Adapter Set | Black Flat | KT0128 |

GND51 THRU AXLE



Black Shiny



| DESCRIPTION | COLOR | ART.-NR. |
|--|---------------|----------|
| GND51 Rigid fork Axle / 15x110mm SQUARE Travel Rigid Fork | ① Black Shiny | AM0060 |
| GND51 X12 Boost Axle / 12x148mm for Models: E-Teru, E-Square, RIOT, E-RIOT, LECTOR, LECTOR FS, Kato FS, SLAMR, Hyb SLAMR, Hyb Square Travel | ② Black Shiny | AM0059 |
| GND51 ASX Boost Axle for E-ASX | ③ Black Shiny | AM0063 |
| GND51 Road Rage AL Front Axle for Road Rage Alloy | ④ Black Shiny | AM0064 |
| GND51 Road Rage AL Rear Axle for Road Rage Alloy Rigid Fork | ⑤ Black Shiny | AM0065 |

GND51 SWITCH LEVER FOR X12



Black Shiny

DE DETAILS

► Hebelwerkzeug mit Flaschenöffner

EN DETAILS

► Axle tool with bottle opener



| DESCRIPTION | COLOR | ART.-NR. |
|---|-------------|----------|
| GND51 Switch Lever for X12 for Axle: AM0059 | Black Shiny | AM0061 |
| GND51 Switch Lever for ASX for Axle: AM0063 | Black Shiny | AM0062 |

LECTOR CHAIN STAY PROTECTION



Black

DE DETAILS

► Kettenstrebenschutz

EN DETAILS

► Chain stay protector



| DESCRIPTION | COLOR | ART.-NR. |
|---|-------|----------|
| LECTOR chain stay protection / top ① | Black | FRPR0036 |
| LECTOR chain stay protection / bottom ② | Black | FRPR0051 |

LECTOR ST COVER



Black

DE DETAILS

- ▶ Gummi für Sitzrohr

EN DETAILS

- ▶ Rubber for seattube



| DESCRIPTION | COLOR | ART.-NR. |
|-----------------|-------|----------|
| LECTOR ST cover | Black | FRPR0037 |

LECTOR FS PROTECTION



Black

DE DETAILS

- ▶ Die Hinterbauprotektoren für dein LECTOR FS
- ▶ Leicht zu montieren

EN DETAILS

- ▶ The rear triangle protection for your LECTOR FS
- ▶ Easy to mount

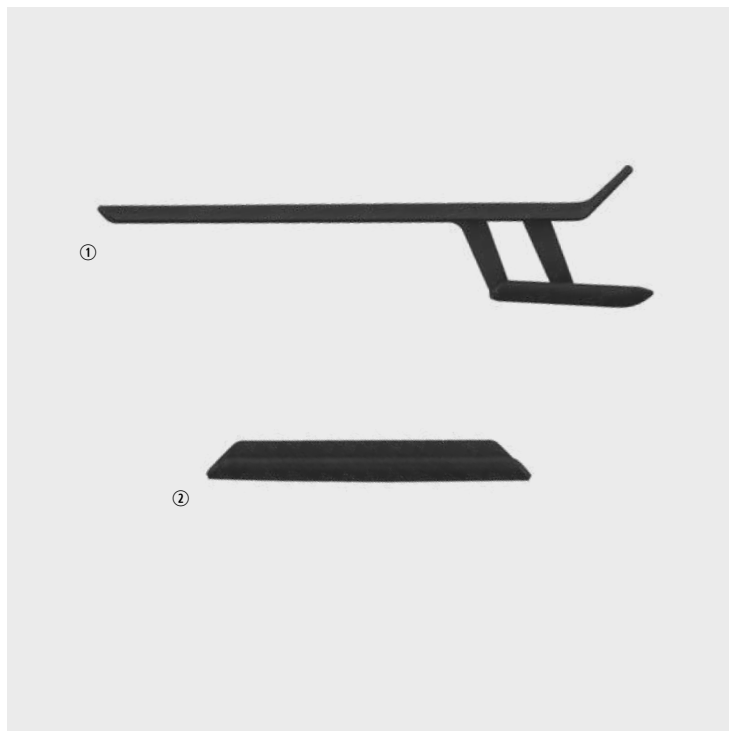

| DESCRIPTION | COLOR | ART.-NR. |
|--------------------------------|---------|----------|
| LECTOR FS Protection chainstay | ① Black | FRPR0067 |
| LECTOR FS Protection seatstay | ② Black | FRPR0068 |

RIOT / E-RIOT PROTECTION



DE DETAILS

- ▶ Der Hinterbauschutz für dein RIOT und E-RIOT
- ▶ Neben dem Schutz der Kettenstrebe und der Sitzstrebe wird hier auch das Yoke geschützt (bei Montage aller Protektoren)
- ▶ Kettenstreben- / Sitzstrebenprotektor in verschiedenen Größen verfügbar

EN DETAILS

- ▶ The rear triangle protector for your RIOT and E-RIOT
- ▶ In addition to protecting the chain stay and seat stay, the yoke is also protected here (if all protections are mounted)
- ▶ Chainstay / seatstay protection available in different sizes

| DESCRIPTION | COLOR | ART.-NR. |
|--|---------|----------|
| RIOT / E-RIOT Protection chainstay / yoke protector | ① Black | FRPR0054 |
| RIOT / E-RIOT Protection / M-XL chainstay / seatstay protector | ② Black | FRPR0055 |
| RIOT / E-RIOT Protection / S chainstay / seatstay protector | ② Black | FRPR0066 |



NIRVANA PROTECTION



DE DETAILS

- ▶ NIRVANA Kettenstrebenschutz
- ▶ Perfekter Sitz auf deinem GHOST-Bike
- ▶ Leicht zu montieren

EN DETAILS

- ▶ NIRVANA chain stay protection
- ▶ Matches your GHOST bike perfectly
- ▶ Easy to mount

| DESCRIPTION | COLOR | ART.-NR. |
|---|-------|----------|
| NIRVANA Protection for framesize XS/ S | Black | FRPR0027 |
| NIRVANA Protection for framesize M / L / XL | Black | FRPR0028 |



RIOT / E-RIOT PROTECTION



DE DETAILS

- ▶ RIOT / E-RIOT Kettenstrebenschutz
- ▶ Perfekter Sitz auf deinem GHOST-Bike
- ▶ Leicht zu montieren

EN DETAILS

- ▶ RIOT / E-RIOT chain stay protection
- ▶ Matches your GHOST bike perfectly
- ▶ Easy to mount



| DESCRIPTION | COLOR | ART.-NR. |
|--------------------------|-------|----------|
| RIOT / E-RIOT Protection | Black | FRPR0053 |

CABLE CLIPS



DE DETAILS

- ▶ Die Kabelführung für dein LECTOR und dein NIRVANA Bike
- ▶ Keine Geräusche, da alle Kabel fixiert sind
- ▶ Unsichtbar unter der Unterrohrabdeckung

EN DETAILS

- ▶ The cable guide for your LECTOR and your NIRVANA bike
- ▶ No noise as all cables are fixed
- ▶ Invisible under the down tube cover

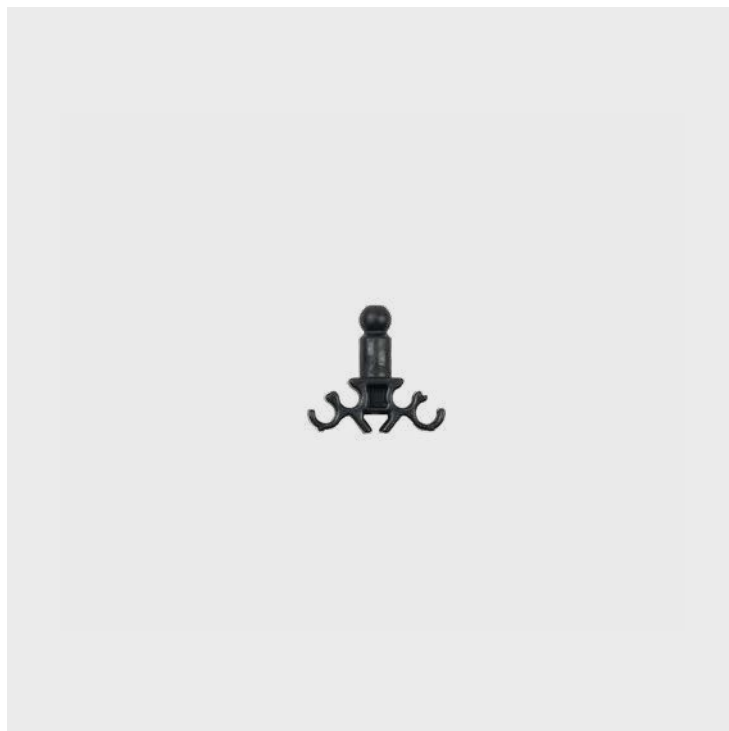

| DESCRIPTION | COLOR | ART.-NR. |
|---------------------------------------|-------|----------|
| LECTOR Cable Clip for Cover Hestling | Black | FROT0075 |
| NIRVANA Cable Clip for Cover Hestling | Black | FROT0062 |
| E-RIOT Cable Clip DT Cover (Top Side) | Black | FRPR0065 |

NIRVANA DT COVER / PROTECTOR



DE DETAILS

- ▶ NIRVANA Unterrohr Abdeckung / Protektor
- ▶ Verfügbar in verschiedenen Größen

EN DETAILS

- ▶ NIRVANA downtube cover / protector
- ▶ Available in different sizes

| DESCRIPTION | COLOR | ART.-NR. |
|--|-------|----------|
| NIRVANA DT Cover / Protector for framesize XXS | Black | FRPR0029 |
| NIRVANA DT Cover / Protector for framesize XS | Black | FRPR0030 |
| NIRVANA DT Cover / Protector for framesize S | Black | FRPR0031 |
| NIRVANA DT Cover / Protector for framesize M/L/XL | Black | FRPR0032 |



LECTOR DT COVER / PROTECTOR



DE DETAILS

- ▶ LECTOR Unterrohr Abdeckung / Protektor
- ▶ Verfügbar in verschiedenen Größen

EN DETAILS

- ▶ LECTOR downtube cover / protector
- ▶ Available in different sizes

| DESCRIPTION | COLOR | ART.-NR. |
|---|-------|----------|
| LECTOR DT Cover / Protector for framesize XS-S | Black | FRPR0033 |
| LECTOR DT Cover / Protector for framesize M | Black | FRPR0034 |
| LECTOR DT Cover / Protector for framesize L-XL | Black | FRPR0035 |



E-RIOT DT CABLECOVER



Black

DE DETAILS

- ▶ E-RIOT Unterrohr Kabel Abdeckung
- ▶ Verfügbar in verschiedenen Größen

EN DETAILS

- ▶ E-RIOT downtube cable cover
- ▶ Available in different sizes

| DESCRIPTION | COLOR | ART.-NR. |
|---|-------|----------|
| E-RIOT DT Cablecover for framesize S | Black | FRPR0059 |
| E-RIOT DT Cablecover for framesize M | Black | FRPR0060 |
| E-RIOT DT Cablecover for framesize L / XL | Black | FRPR0061 |



E-RIOT MOTOR COVER GEN4



Black

DE DETAILS

- ▶ Abdeckung für den GEN4 Motor
- ▶ Besteht aus zwei Teilen (linke / rechte Seite)

EN DETAILS

- ▶ Cover for the GEN4 engine
- ▶ Consists of two parts (left / right side)

| DESCRIPTION | COLOR | ART.-NR. |
|-------------------------------|-------|----------|
| E-RIOT Motor Cover Gen4 Left | Black | FRPR0063 |
| E-RIOT Motor Cover Gen4 Right | Black | FRPR0064 |



CHAIN STAY CABLE HOLDER FOR NIRVANA



Black

DE DETAILS

- ▶ Die Kabelführung für dein NIRVANA Bike
- ▶ Die Kabelführung wird an der Kettenstrebe befestigt

EN DETAILS

- ▶ The cable guide for your NIRVANA bike
- ▶ The cable guide is attached to the chain stay



| DESCRIPTION | COLOR | ART.-NR. |
|-----------------------------------|-------|----------|
| Chain Stay Cable Clip for NIRVANA | Black | FROT0068 |

O-RING FOR CHAIN STAY CLIP NIRVANA



Black

DE DETAILS

- ▶ O-Ring für Kettenstrebenhalter Clip 2,5 x 40 mm

EN DETAILS

- ▶ O-Ring for Chain Stay Holder Clip 2,5 x 40 mm

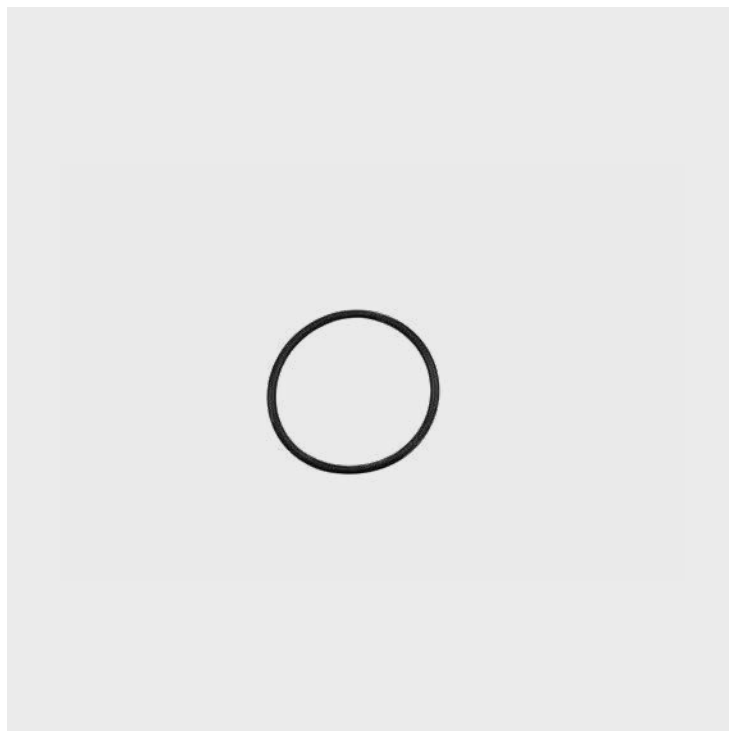

| DESCRIPTION | COLOR | ART.-NR. |
|------------------------------------|-------|----------|
| O-Ring for Chain Stay Clip NIRVANA | Black | FROT0070 |

DISCONNECT BRAKEMOUNT



DE DETAILS

- ▶ Die Bremsaufnahme für dein GHOST Bike
- ▶ Passt zu Bremscheiben in den Größen 160 mm, 180 mm, 200 mm, 203 mm







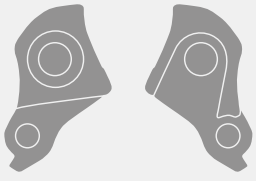

EN DETAILS

- ▶ The brake mount for your GHOST bike
- ▶ Fits to brake discs in the sizes 160 mm, 180 mm, 200 mm, 203 mm

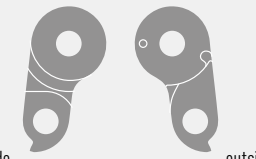
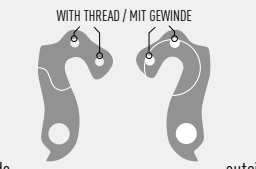

| DESCRIPTION | | COLOR | ART.-NR. |
|---------------------------------|---|-------|----------|
| Disconnect Brakemount PM 180mm | ① | Black | FROT0202 |
| Disconnect Brakemount PM 160 mm | ② | Black | FROT0191 |

SCHALTAUGENÜBERSICHT // HANGER OVERVIEW









| PICTURE | NAME | ART.-NR. | BIKE |
|--|---|--------------------------|---|
|  <p>inside outside</p> | <p>SRAM UDH Hanger set with nut AL black</p> | FRHG0061 | <p>HYB ASX '21, '22, '23 RIOT AL '21, '22, '23 RIOT YOUTH '22 RIOT CF '23 E-RIOT '21, '22, '23 LECTOR FS '21, '22, '23 E-TERU '23 (not for E-TERU Essential) KATO FS '22, '23 PATH ASKET '23 PATH RIOT CF '23</p> |
|  <p>inside outside</p> | <p>Hanger AL black Set incl. screws</p> | FRHG0064 | <p>KATO KID 20" '22, '23 KATO KID 24" '22, '23 LANAO KID 20" '22, '23 LANAO KID 24" '22, '23</p> |
|  <p>inside outside</p> | <p>Hanger RD 156 Screw hex 2,5 inbus M3 x 6 mm</p> | FRHG0003 FRSC0003 | <p>ROAD RAGE '18, '19 FIRE ROAD RAGE '18, '19, '20, '21 ENDLESS ROAD RAGE '18, '19, '20 VIOLENT ROAD RAGE '18, '19 ROAD RAGE PRO '22</p> |
|  <p>inside outside</p> | <p>Hanger GRH-21bl black Screw 2x M4 x 8 mm T20 black</p> | FRHG0004 FRSC0059 | <p>KATO '21, '22, '23 LANAO '21, '22, '23 SQUARE TREKKING '21, '22, '23 SQUARE CROSS '21, '22, '23</p> |
|  <p>inside outside</p> | <p>Hanger set with nut & screw AL6061 black thread P1</p> | FRHG0065 | ASKETAL '23 |
|  <p>inside outside</p> | <p>Hanger AL6061-T6 black anodized</p> | FRHG0025 | <p>NIRVANA '20, '21, '22, '23 LECTOR LC SF '20, '21, '22, '23 E-TERU YOUTH '23 E-TERU ESSENTIAL '23 E-TERU '21, '22</p> |
|  <p>inside outside</p> | <p>Hanger set with nut & screw AL6061 black thread P1.5</p> | FRHG0062 | ROAD RAGE AL '21, '22 |
|  <p>inside outside</p> | <p>Adjustable hanger right side</p> | W0017215 | <p>E-TERU LOW UNIVERSAL '22 E-TERU LOW ESSENTIAL '22</p> |
|  <p>inside outside</p> | <p>Adjustable brakemount left side</p> | W0017214 | <p>E-TERU LOW UNIVERSAL '22 E-TERU LOW ESSENTIAL '22</p> |

FIND ALL HANGERS ON OUR WEBSITE:
WWW.GHOST-BIKES.COM/DOWNLOADS/TECHNISCHE-DOKUMENTE-1



STÄNDERÜBERSICHT // KICKSTAND OVERVIEW

| MODEL | ADAPTER # | KICKSTAND # | KICKSTAND | POSITION |
|------------------------------|-------------------|-------------|--|----------|
| E-TERU & E-TERU LOW | GA0128 | AM0010 | Ursus M001 R90 rear-18mm M6 holes 26" to 29" | rear |
| KATO FS & RIOT YOUTH | | | | |
| NIRVANA TOUR & NIRVANA TRAIL | KT0126 | | | |
| E-RIOT AL E-RIOT CF | KT0127 | AM0013 | Ursus M001 R90 rear-40mm M6 threads 26" to 29" | center |
| RIOT AL | | | | |
| KATO 27,5", 29" | no adapter needed | | | |
| LANAO 27,5", 29" | | | | |
| SQUARE CROSS | | AM0049 | Nuvo kickstand 20"-28 18mm | rear |
| SQUARE TREKKING | | | | |
| KATO 20" LANA0 20" | | | | |
| KATO 24" LANA0 24" | | AM0012 | Ursus M001 R90 rear-40mm M6 holes 26" to 29" | rear |
| ASKET AL | | | | |
| E-ASX (only 130 mm Version) | | AM0010 | Ursus M001 R90 rear-18mm M6 holes 26" to 29" | rear |

| DESCRIPTION | COLOR | ART.-NR. | PICTURE |
|--|-------------|----------|---|
| Ursus M001 R90 rear-18mm | Black Shiny | AM0010 |  |
| Ursus M001 R90 rear-40mm | Black Shiny | AM0013 |  |
| Ursus easy 92 center-mid | Black Shiny | AM0015 |  |
| Nuvo 20" to 28" - 18mm | Black Shiny | AM0049 |  |
| Ursus M001 R90 rear-40mm M6 holes 26" to 29" | Black Shiny | AM0012 |  |
| Ursus M001 R90 rear-18mm M6 holes 26" to 29" | Black Shiny | AM0010 |  |
| Kickstand adapter (E-TERU, E-TERU LOW, KATO FS, RIOT YOUTH) | Black | GA0128 |  |
| Kickstand adapter (E-RIOT AL / CF, RIOT AL) | Black | KT0127 |  |
| Kickstand adapter (NIRVANA TOUR, NIRVANA TRAIL) | Black | KT0126 |  |

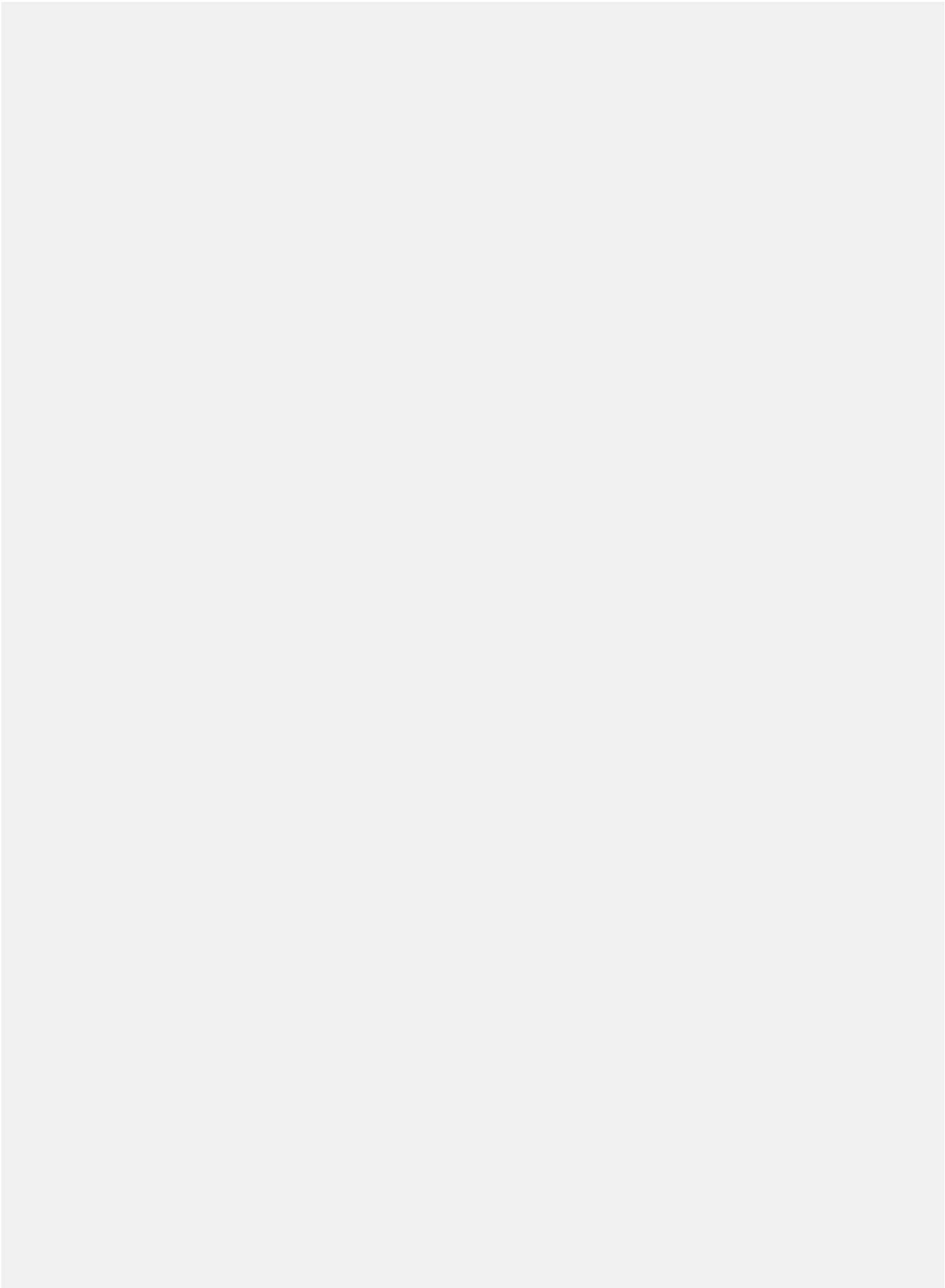

INFO

BIKE ANATOMIE

GEOMETRIEN

TECHNIK LEXIKON

EINSATZBEREICHE

BIKE ANATOMIE / BIKE ANATOMY









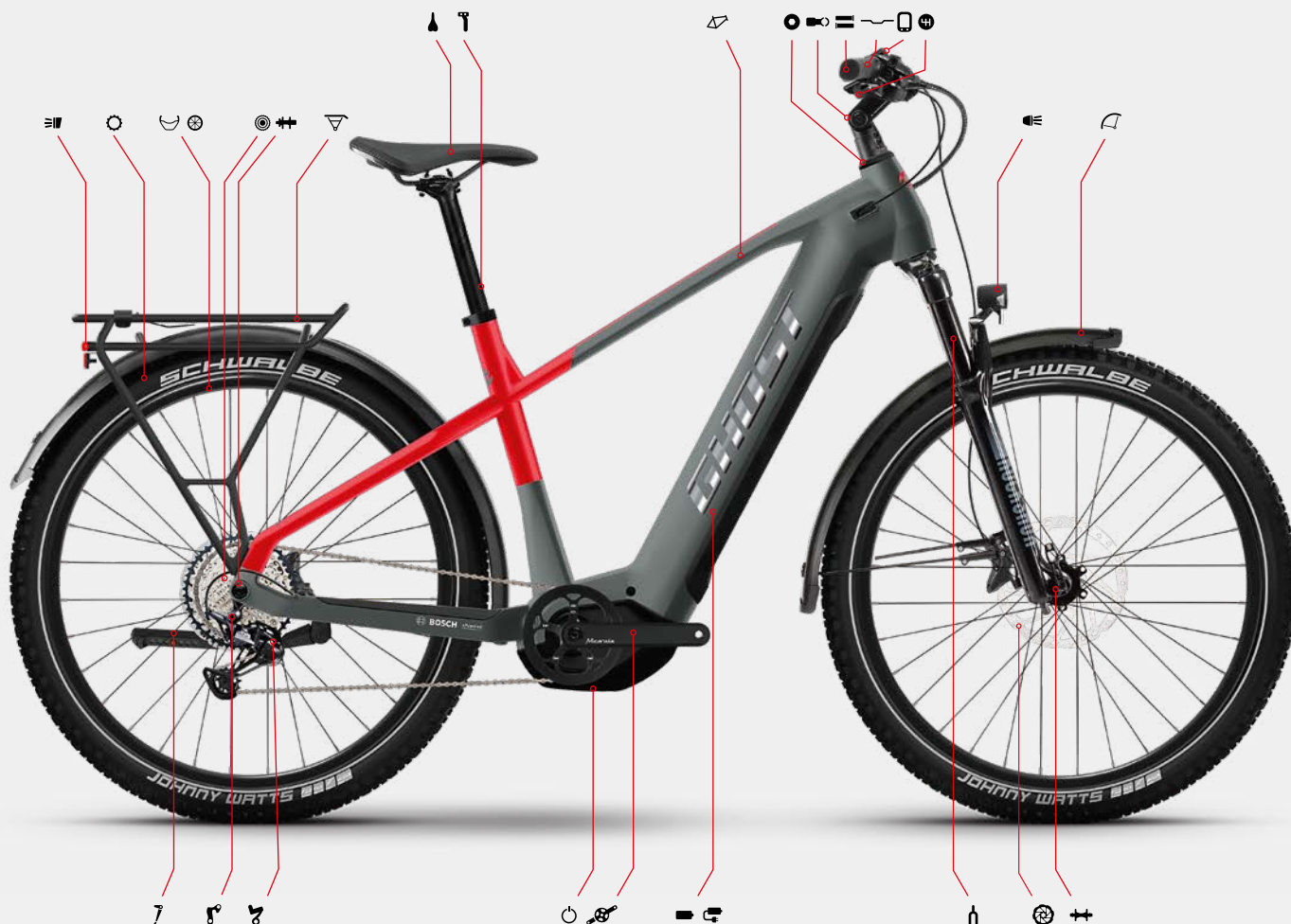







// ERKLÄRUNG / EXPLANATION

| | | | |
|---|---|--|--|
|  RAHMEN FRAME |  SCHALTWERK REAR DERAILLEUR |  LAUFRÄDER WHEELSET |  SATTEL SADDLE |
|  GABEL UND FEDERWEG VORNE FORK AND FRONT TRAVEL |  UMWERFER FRONT DERAILLEUR |  REIFEN TIRES |  STEUERSATZ HEADSET |
|  FEDERELEMENT UND FEDERWEG HINTEN SHOCK AND REAR TRAVEL |  SCHALTHEBEL SHIFTER |  FELGE RIM |  INNENLAGER BOTTOM BRACKET |
|  VORBAU STEM |  KURBELSATZ CRANKSET |  NABE VORNE FRONT HUB |  SCHALTAUGE HANGER |
|  GRIFFE GRIPS |  KASSETTE CASSETTE |  NABE HINTEN REAR HUB | |
|  LENKER HANDLEBAR |  BREMSEN BRAKES |  SATTELSTÜTZE SEATPOST | |

E-BIKE ANATOMIE / EBIKE ANATOMY



// ERKLÄRUNG / EXPLANATION

| | | | |
|---|---|--|--|
|  RAHMEN FRAME |  SCHALTHEBEL SHIFTER |  NABE HINTEN REAR HUB |  DISPLAY DISPLAY |
|  GABEL UND FEDERWEG VORNE FORK AND FRONT TRAVEL |  KURBELSATZ CRANKSET |  SATTELSTÜTZE SEATPOST |  MOTOR MOTOR |
|  FEDERELEMENT UND FEDERWEG HINTEN SHOCK AND REAR TRAVEL |  KASSETTE CASSETTE |  SATTEL SADDLE |  BATTERIE BATTERY |
|  VORBAU STEM |  BREMSEN BRAKES |  GEPÄCKTRÄGER CARRIER |  LADEGERÄT CHARGER |
|  GRIFFE GRIPS |  LAUFRÄDER WHEELSET |  SCHUTZBLECHE FENDERS |  STEUERSATZ HEADSET |
|  LENKER HANDLEBAR |  REIFEN TIRES |  STÄNDER KICK STAND |  INNENLAGER BOTTOM BRACKET |
|  SCHALTWERK REAR DERAILLEUR |  FELGE RIM |  SCHEINWERFER LIGHTS FRONT |  SCHALTAUGE HANGER |
|  UMWERFER FRONT DERAILLEUR |  NABE VORNE FRONT HUB |  RÜCKLICHT LIGHTS REAR | |

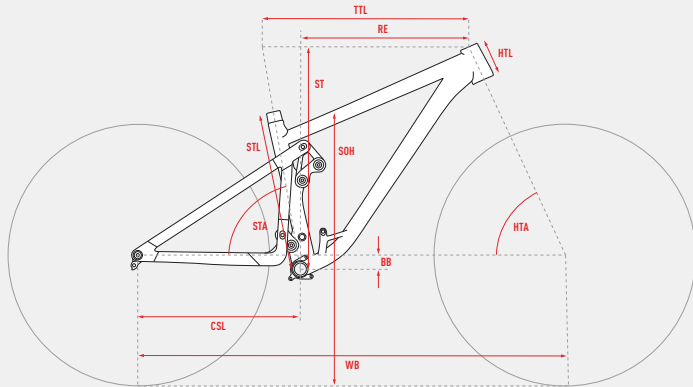

ALL DIMENSIONS IN MM (EXCEPT HTA AND STA IN °)

ALLE MASSE IN MM (AUSNAHME HTA UND STA IN °)

- STL** SEAT TUBE LENGTH
SITZROHRLÄNGE
- CSL** CHAINSTAY LENGTH
KETTENSTREBENLÄNGE
- TTL** TOP TUBE LENGTH
OBERROHRLÄNGE
- HTL** HEAD TUBE LENGTH
STEUERROHRLÄNGE
- HTA** HEAD TUBE ANGLE
STEUERROHRWINKEL
- STA** SEAT TUBE ANGLE
SITZROHRWINKEL
- BB** BOTTOM BRACKET DROP
INNENLAGERABSENKUNG
- WB** WHEELBASE
RADSTAND
- ST** STACK
STACK
- RE** REACH
REACH
- SOH** STANDOVER HEIGHT
ÜBERSTANDSHÖHE
- HEAD SET DIAMETER (UPPER / LOWER)
STEUERSATZDURCHMESSER (OBEN / UNTEN)
- AXLE STANDARD (REAR / FRONT)
ACHSENSTANDARD (HINTEN / VORNE)
- BOTTOM BRACKET STANDARD
TRETLAGERSTANDARD
- SEAT POST DIAMETER
SITTELSTÜTZENDURCHMESSER
- SHOCK HARDWARE (Ø 8 MM)
DÄMPFERBUCHSENMASSE (Ø 8 MM)
- SHOCK LENGTH
DÄMPFERENBAULÄNGE
- SHOCK TRAVEL
DÄMPFERHUB
- FRONT FORK TRAVEL
FEDERWEG VORNE
- REAR WHEEL TRAVEL
FEDERWEG HINTEN
- STEM LENGTH
VORBAULÄNGE
- HANDLEBAR WIDTH
LENKERBREITE
- CRANK LENGTH
KURBELLÄNGE
- SEAT TUBE BOTTLE MOUNT
FLASCHE SITTELROHR
- DOWNTUBE BOTTLE MOUNT
FLASCHE UNTERROHR

| | STL | CSL | TTL | HTL | HTA | STA | BB | WB | ST | RE | SOH | | | | | | | | | | | | | | |
|---------------------------|-----|-----|-----|-----|-----|-----|----|------|-----|-----|-----|---------|---------|--------|------|------------------|-----|----|-----|-----|----|-----|-----|---|------|
| RIOT EN FULL PARTY | | | | | | | | | | | | | | | | | | | | | | | | | |
| S | 417 | 435 | 607 | 120 | 64 | 76 | 24 | 1224 | 619 | 453 | 740 | 44 / 56 | 148/110 | BSA 73 | 34.9 | Trunnion / 30x10 | 205 | 65 | 170 | 160 | 45 | 760 | 165 | - | 0.5 |
| M | 441 | 455 | 621 | 100 | 64 | 77 | 38 | 1276 | 627 | 477 | 752 | 44 / 56 | 148/110 | BSA 73 | 34.9 | Trunnion / 30x10 | 205 | 65 | 170 | 160 | 45 | 780 | 165 | - | 0.75 |
| L | 465 | 455 | 651 | 140 | 64 | 77 | 38 | 1315 | 663 | 498 | 755 | 44 / 56 | 148/110 | BSA 73 | 34.9 | Trunnion / 30x10 | 205 | 65 | 170 | 160 | 45 | 780 | 170 | - | 0.75 |
| XL | 489 | 455 | 685 | 160 | 64 | 77 | 38 | 1353 | 681 | 528 | 754 | 44 / 56 | 148/110 | BSA 73 | 34.9 | Trunnion / 30x10 | 205 | 65 | 170 | 160 | 45 | 780 | 170 | - | 0.75 |

| | STL | CSL | TTL | HTL | HTA | STA | BB | WB | ST | RE | SOH | | | | | | | | | | | | | | |
|--------------------|-----|-----|-----|-----|-----|-----|----|------|-----|-----|-----|---------|---------|--------|------|------------------|-----|----|-----|-----|----|-----|-----|---|------|
| RIOT EN PRO | | | | | | | | | | | | | | | | | | | | | | | | | |
| S | 417 | 435 | 607 | 120 | 64 | 76 | 24 | 1225 | 619 | 453 | 740 | 44 / 56 | 148/110 | BSA 73 | 34.9 | Trunnion / 30x10 | 205 | 65 | 170 | 160 | 45 | 760 | 165 | - | 0.5 |
| M | 441 | 455 | 621 | 100 | 64 | 77 | 38 | 1276 | 627 | 477 | 752 | 44 / 56 | 148/110 | BSA 73 | 34.9 | Trunnion / 30x10 | 205 | 65 | 170 | 160 | 45 | 780 | 165 | - | 0.75 |
| L | 465 | 455 | 651 | 140 | 64 | 77 | 38 | 1315 | 663 | 498 | 755 | 44 / 56 | 148/110 | BSA 73 | 34.9 | Trunnion / 30x10 | 205 | 65 | 170 | 160 | 45 | 780 | 170 | - | 0.75 |
| XL | 489 | 455 | 685 | 160 | 64 | 77 | 38 | 1353 | 681 | 528 | 754 | 44 / 56 | 148/110 | BSA 73 | 34.9 | Trunnion / 30x10 | 205 | 65 | 170 | 160 | 45 | 780 | 170 | - | 0.75 |



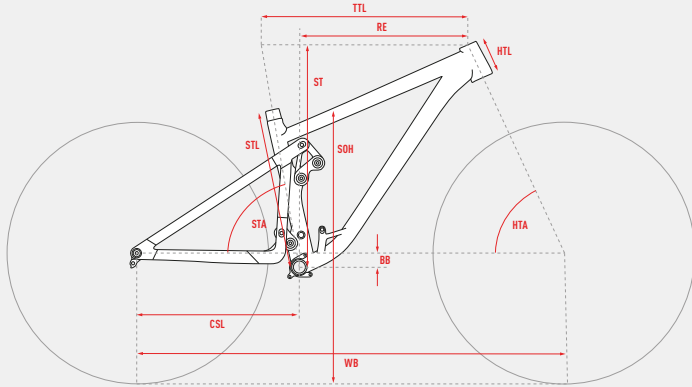











| | STL | CSL | TTL | HTL | HTA | STA | BB | WB | ST | RE | SOH | | | | | | | | | | | | | | |
|--------------------------|-----|-----|-----|-----|-----|-----|----|------|-----|-----|-----|---------|---------|--------|------|------------------|-----|----|-----|-----|----|-----|-----|---|------|
| RIOT EN ESSENTIAL | | | | | | | | | | | | | | | | | | | | | | | | | |
| S | 417 | 435 | 607 | 120 | 64 | 76 | 24 | 1225 | 619 | 453 | 740 | 44 / 56 | 148/110 | BSA 73 | 34.9 | Trunnion / 30x10 | 205 | 65 | 170 | 160 | 45 | 760 | 165 | - | 0.5 |
| M | 441 | 455 | 621 | 100 | 64 | 77 | 38 | 1276 | 627 | 477 | 752 | 44 / 56 | 148/110 | BSA 73 | 34.9 | Trunnion / 30x10 | 205 | 65 | 170 | 160 | 45 | 780 | 165 | - | 0.75 |
| L | 465 | 455 | 651 | 140 | 64 | 77 | 38 | 1315 | 663 | 498 | 755 | 44 / 56 | 148/110 | BSA 73 | 34.9 | Trunnion / 30x10 | 205 | 65 | 170 | 160 | 45 | 780 | 170 | - | 0.75 |
| XL | 489 | 455 | 685 | 160 | 64 | 77 | 38 | 1353 | 681 | 528 | 754 | 44 / 56 | 148/110 | BSA 73 | 34.9 | Trunnion / 30x10 | 205 | 65 | 170 | 160 | 45 | 780 | 170 | - | 0.75 |













ALL DIMENSIONS IN MM (EXCEPT HTA AND STA IN °)















ALLE MASSE IN MM (AUSNAHME HTA UND STA IN °)

- STL** SEAT TUBE LENGTH
SITZROHRLÄNGE
- CSL** CHAINSTAY LENGTH
KETTENSTREBELÄNGE
- TTL** TOP TUBE LENGTH
OBERROHRLÄNGE
- HTL** HEAD TUBE LENGTH
STEUERROHRLÄNGE
- HTA** HEAD TUBE ANGLE
STEUERROHRWINKEL
- STA** SEAT TUBE ANGLE
SITZROHRWINKEL
- BB** BOTTOM BRACKET DROP
INNENLAGERABSENKUNG
- WB** WHEELBASE
RADSTAND
- ST** STACK
STACK
- RE** REACH
REACH
- SOH** STANDOVER HEIGHT
ÜBERSTANDSHÖHE
-  HEAD SET DIAMETER (UPPER / LOWER)
STEUERSATZDURCHMESSER (OBEN / UNTEN)
-  AXLE STANDARD (REAR / FRONT)
ACHSENSTANDARD (HINTEN / VORNE)
-  BOTTOM BRACKET STANDARD
TRETLAGERSTANDARD
-  SEAT POST DIAMETER
SITZELSTÜTZENDURCHMESSER
-  SHOCK HARDWARE (Ø 8 MM)
DÄMPFERBUCHSENMASSE (Ø 8 MM)
-  SHOCK LENGTH
DÄMPFERENBAULÄNGE
-  SHOCK TRAVEL
DÄMPFERHUB
-  FRONT FORK TRAVEL
FEDERWEG VORNE
-  REAR WHEEL TRAVEL
FEDERWEG HINTEN
-  STEM LENGTH
VORBAULÄNGE
-  HANDLEBAR WIDTH
LENKERBREITE
-  CRANK LENGTH
KURBELLÄNGE
-  SEAT TUBE BOTTLE MOUNT
FLASCHE SITZELROHR
-  DOWNTUBE BOTTLE MOUNT
FLASCHE UNTERROHR















STL CSL TTL HTL HTA STA BB WB ST RE SOH              

RIOT AM UNIVERSAL

| | STL | CSL | TTL | HTL | HTA | STA | BB | WB | ST | RE | SOH |  |  |  |  |  |  |  |  |  |  |  |  |  |  |
|----|-----|-----|-----|-----|-----|-----|----|------|-----|-----|-----|---|---|---|---|---|---|---|---|---|---|---|---|---|---|
| S | 417 | 435 | 606 | 120 | 64 | 76 | 28 | 1220 | 616 | 457 | 737 | 44 / 56 | 148/110 | BSA 73 | 34.9 | Trunnion / 30x10 | 205 | 60 | 160 | 150 | 45 | 760 | 165 | - | 0.5 |
| M | 441 | 455 | 620 | 100 | 64 | 77 | 41 | 1272 | 624 | 481 | 750 | 44 / 56 | 148/110 | BSA 73 | 34.9 | Trunnion / 30x10 | 205 | 60 | 160 | 150 | 45 | 780 | 165 | - | 0.75 |
| L | 465 | 455 | 650 | 140 | 64 | 77 | 41 | 1310 | 660 | 502 | 752 | 44 / 56 | 148/110 | BSA 73 | 34.9 | Trunnion / 30x10 | 205 | 60 | 160 | 150 | 45 | 780 | 170 | - | 0.75 |
| XL | 489 | 455 | 684 | 160 | 64 | 77 | 41 | 1349 | 678 | 532 | 751 | 44 / 56 | 148/110 | BSA 73 | 34.9 | Trunnion / 30x10 | 205 | 60 | 160 | 150 | 45 | 780 | 170 | - | 0.75 |

STL CSL TTL HTL HTA STA BB WB ST RE SOH              





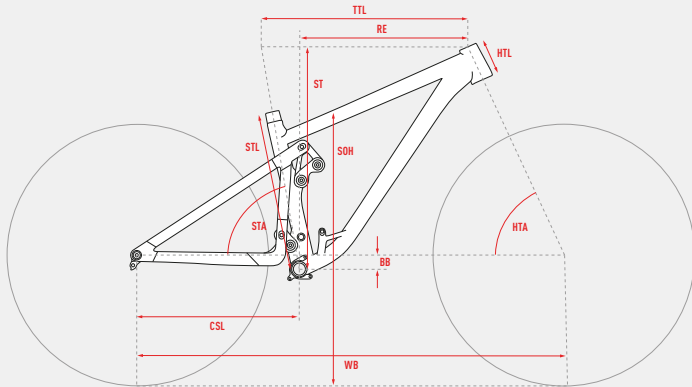





RIOT AM ESSENTIAL















| | STL | CSL | TTL | HTL | HTA | STA | BB | WB | ST | RE | SOH |  |  |  |  |  |  |  |  |  |  |  |  |  |  |
|----|-----|-----|-----|-----|-----|-----|----|------|-----|-----|-----|---|---|---|---|---|---|---|---|---|---|---|---|---|---|
| S | 417 | 435 | 606 | 120 | 64 | 76 | 28 | 1220 | 616 | 457 | 737 | 44 / 56 | 148/110 | BSA 73 | 34.9 | Trunnion / 30x10 | 205 | 60 | 160 | 150 | 45 | 760 | 165 | - | 0.5 |
| M | 441 | 455 | 620 | 100 | 64 | 77 | 41 | 1272 | 624 | 481 | 750 | 44 / 56 | 148/110 | BSA 73 | 34.9 | Trunnion / 30x10 | 205 | 60 | 160 | 150 | 45 | 780 | 165 | - | 0.75 |
| L | 465 | 455 | 650 | 140 | 64 | 77 | 41 | 1310 | 660 | 502 | 752 | 44 / 56 | 148/110 | BSA 73 | 34.9 | Trunnion / 30x10 | 205 | 60 | 160 | 150 | 45 | 780 | 170 | - | 0.75 |
| XL | 489 | 455 | 684 | 160 | 64 | 77 | 41 | 1349 | 678 | 532 | 751 | 44 / 56 | 148/110 | BSA 73 | 34.9 | Trunnion / 30x10 | 205 | 60 | 160 | 150 | 45 | 780 | 170 | - | 0.75 |



ALL DIMENSIONS IN MM (EXCEPT HTA AND STA IN °)

ALLE MASSE IN MM (AUSNAHME HTA UND STA IN °)

- STL** SEAT TUBE LENGTH
SITZROHRLÄNGE
- CSL** CHAINSTAY LENGTH
KETTENSTREBENLÄNGE
- TTL** TOP TUBE LENGTH
OBERROHRLÄNGE
- HTL** HEAD TUBE LENGTH
STEUERROHRLÄNGE
- HTA** HEAD TUBE ANGLE
STEUERROHRWINKEL
- STA** SEAT TUBE ANGLE
SITZROHRWINKEL
- BB** BOTTOM BRACKET DROP
INNENLAGERABSENKUNG
- WB** WHEELBASE
RADSTAND
- ST** STACK
STACK
- RE** REACH
REACH
- SOH** STANDOVER HEIGHT
ÜBERSTANDSHÖHE
-  HEAD SET DIAMETER (UPPER / LOWER)
STEUERSATZDURCHMESSER (OBEN / UNTEN)
-  AXLE STANDARD (REAR / FRONT)
ACHSENSTANDARD (HINTEN / VORNE)
-  BOTTOM BRACKET STANDARD
TRETLAGERSTANDARD
-  SEAT POST DIAMETER
SITZELSTÜTZENDURCHMESSER
-  SHOCK HARDWARE (Ø 8 MM)
DÄMPFERBUCHSENMASSE (Ø 8 MM)
-  SHOCK LENGTH
DÄMPFERENBAULÄNGE
-  SHOCK TRAVEL
DÄMPFERHUB
-  FRONT FORK TRAVEL
FEDERWEG VORNE
-  REAR WHEEL TRAVEL
FEDERWEG HINTEN
-  STEM LENGTH
VORBAULÄNGE
-  HANDLEBAR WIDTH
LENKERBREITE
-  CRANK LENGTH
KURBELLÄNGE
-  SEAT TUBE BOTTLE MOUNT
FLASCHE SITZELROHR
-  DOWNTUBE BOTTLE MOUNT
FLASCHE UNTERROHR

STL CSL TTL HTL HTA STA BB WB ST RE SOH              

RIOT TRAIL ESSENTIAL

| | STL | CSL | TTL | HTL | HTA | STA | BB | WB | ST | RE | SOH |  |  |  |  |  |  |  |  |  |  |  |  |  |  |
|-----------|-----|-----|-----|-----|-----|-----|----|------|-----|-----|-----|---|---|---|---|---|---|---|---|---|---|---|---|---|---|
| S | 417 | 430 | 596 | 100 | 66 | 76 | 25 | 1180 | 587 | 450 | 772 | 44 / 56 | 148/110 | BSA 73 | 34.9 | Trunnion / 30x10 | 185 | 55 | 140 | 140 | 45 | 760 | 170 | - | 0.5 |
| M | 441 | 450 | 609 | 100 | 66 | 77 | 39 | 1230 | 615 | 467 | 800 | 44 / 56 | 148/110 | BSA 73 | 34.9 | Trunnion / 30x10 | 185 | 55 | 140 | 140 | 45 | 780 | 170 | - | 0.75 |
| L | 465 | 450 | 638 | 140 | 66 | 77 | 39 | 1266 | 652 | 487 | 803 | 44 / 56 | 148/110 | BSA 73 | 34.9 | Trunnion / 30x10 | 185 | 55 | 140 | 140 | 45 | 780 | 175 | - | 0.75 |
| XL | 489 | 450 | 670 | 160 | 66 | 77 | 39 | 1303 | 670 | 516 | 802 | 44 / 56 | 148/110 | BSA 73 | 34.9 | Trunnion / 30x10 | 185 | 55 | 140 | 140 | 45 | 780 | 175 | - | 0.75 |

RIOT TRAIL

| | STL | CSL | TTL | HTL | HTA | STA | BB | WB | ST | RE | SOH |  |  |  |  |  |  |  |  |  |  |  |  |  |  |
|-----------|-----|-----|-----|-----|-----|-----|----|------|-----|-----|-----|---|---|---|---|---|---|---|---|---|---|---|---|---|---|
| S | 417 | 430 | 596 | 100 | 66 | 76 | 25 | 1180 | 587 | 449 | 772 | 44 / 56 | 148/110 | BSA 73 | 34.9 | Trunnion / 30x10 | 185 | 55 | 140 | 140 | 45 | 760 | 170 | - | 0.5 |
| M | 441 | 450 | 609 | 100 | 66 | 77 | 39 | 1230 | 615 | 467 | 800 | 44 / 56 | 148/110 | BSA 73 | 34.9 | Trunnion / 30x10 | 185 | 55 | 140 | 140 | 45 | 780 | 170 | - | 0.75 |
| L | 465 | 450 | 638 | 140 | 66 | 77 | 39 | 1266 | 652 | 487 | 803 | 44 / 56 | 148/110 | BSA 73 | 34.9 | Trunnion / 30x10 | 185 | 55 | 140 | 140 | 45 | 780 | 175 | - | 0.75 |
| XL | 489 | 450 | 670 | 160 | 66 | 77 | 39 | 1303 | 670 | 516 | 802 | 44 / 56 | 148/110 | BSA 73 | 34.9 | Trunnion / 30x10 | 185 | 55 | 140 | 140 | 45 | 780 | 175 | - | 0.75 |

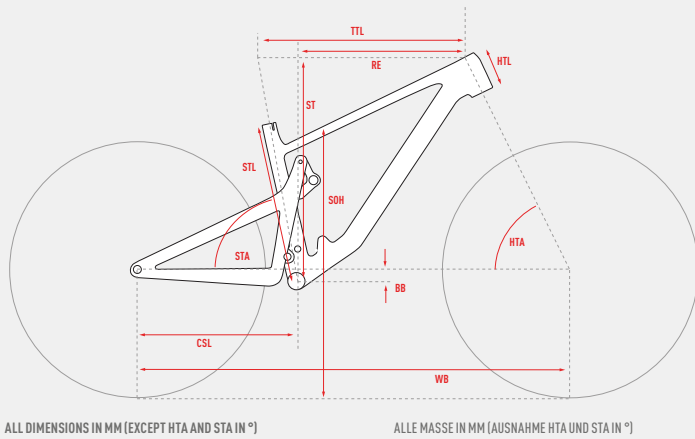















ALL DIMENSIONS IN MM (EXCEPT HTA AND STA IN °)

ALLE MASSE IN MM (AUSNAHME HTA UND STA IN °)















- STL** SEAT TUBE LENGTH
SITZROHRLÄNGE
- CSL** CHAINSTAY LENGTH
KETTENSTREBENLÄNGE
- TTL** TOP TUBE LENGTH
OBERROHRLÄNGE
- HTL** HEAD TUBE LENGTH
STEUERROHRLÄNGE
- HTA** HEAD TUBE ANGLE
STEUERROHRWINKEL
- STA** SEAT TUBE ANGLE
SITZROHRWINKEL
- BB** BOTTOM BRACKET DROP
INNENLAGERABSENKUNG
- WB** WHEELBASE
RADSTAND
- ST** STACK
STACK
- RE** REACH
REACH
- SOH** STANDOVER HEIGHT
ÜBERSTANDSHÖHE
-  **HEAD SET DIAMETER (UPPER / LOWER)**
STEUERSATZDURCHMESSER (OBEN / UNTEN)

-  **AXLE STANDARD (REAR / FRONT)**
ACHSENSTANDARD (HINTEN / VORNE)
-  **BOTTOM BRACKET STANDARD**
TRETLAGERSTANDARD
-  **SEAT POST DIAMETER**
SÄTTELSTÜTZENDURCHMESSER
-  **SHOCK HARDWARE (Ø 8 MM)**
DÄMPFERBUCHSENMASSE (Ø 8 MM)
-  **SHOCK LENGTH**
DÄMPFEREINBAULÄNGE
-  **SHOCK TRAVEL**
DÄMPFERHUB
-  **FRONT FORK TRAVEL**
FEDERWEG VORNE
-  **REAR WHEEL TRAVEL**
FEDERWEG HINTEN
-  **STEM LENGTH**
VORBAULÄNGE
-  **HANDLEBAR WIDTH**
LENKERBREITE
-  **CRANK LENGTH**
KURBELLÄNGE
-  **SEAT TUBE BOTTLE MOUNT**
FLASCHE SÄTTELROHR
-  **DOWNTUBE BOTTLE MOUNT**
FLASCHE UNTERROHR

STL CSL TTL HTL HTA STA BB WB ST RE SOH              















RIOT AM FULL PARTY

| | STL | CSL | TTL | HTL | HTA | STA | BB | WB | ST | RE | SOH |  |  |  |  |  |  |  |  |  |  |  |  |  |  |
|----|-----|-----|-----|-----|------|------|------|------|-----|-----|-----|---|---|---|---|---|---|---|---|---|---|---|---|---|---|
| S | 417 | 446 | 581 | 90 | 63.5 | 76.5 | 34.2 | 1224 | 607 | 435 | 746 | 0 / 0 | 148/110 | 34,9 | Trunnion / 30x10 | 185 | 55 | 160 | 140 | 40 | 760 | 170 | - | 0,5 | |
| M | 441 | 446 | 615 | 110 | 63.5 | 76.5 | 34.3 | 1263 | 626 | 465 | 753 | 0 / 0 | 148/110 | 34,9 | Trunnion / 30x10 | 185 | 55 | 160 | 140 | 40 | 800 | 170 | - | 0,75 | |
| L | 465 | 455 | 647 | 140 | 63.5 | 76.5 | 29.5 | 1312 | 648 | 492 | 778 | 0 / 0 | 148/110 | 34,9 | Trunnion / 30x10 | 185 | 55 | 160 | 140 | 40 | 800 | 175 | - | 0,75 | |
| XL | 489 | 455 | 681 | 160 | 63.5 | 76.5 | 29.6 | 1350 | 666 | 522 | 796 | 0 / 0 | 148/110 | 34,9 | Trunnion / 30x10 | 185 | 55 | 160 | 140 | 40 | 800 | 175 | - | 0,75 | |

STL CSL TTL HTL HTA STA BB WB ST RE SOH              















RIOT AM PRO

| | STL | CSL | TTL | HTL | HTA | STA | BB | WB | ST | RE | SOH |  |  |  |  |  |  |  |  |  |  |  |  |  |  |
|----|-----|-----|-----|-----|------|------|------|------|-----|-----|-----|---|---|---|---|---|---|---|---|---|---|---|---|---|---|
| S | 417 | 446 | 581 | 90 | 63.5 | 76.5 | 34.2 | 1224 | 607 | 435 | 746 | 0 / 0 | 148/110 | 34,9 | Trunnion / 30x10 | 185 | 55 | 160 | 140 | 40 | 760 | 170 | - | 0,5 | |
| M | 441 | 446 | 615 | 110 | 63.5 | 76.5 | 34.3 | 1263 | 626 | 465 | 753 | 0 / 0 | 148/110 | 34,9 | Trunnion / 30x10 | 185 | 55 | 160 | 140 | 40 | 800 | 170 | - | 0,75 | |
| L | 465 | 455 | 647 | 140 | 63.5 | 76.5 | 29.5 | 1312 | 648 | 492 | 778 | 0 / 0 | 148/110 | 34,9 | Trunnion / 30x10 | 185 | 55 | 160 | 140 | 40 | 800 | 175 | - | 0,75 | |
| XL | 489 | 455 | 681 | 160 | 63.5 | 76.5 | 29.6 | 1350 | 666 | 522 | 796 | 0 / 0 | 148/110 | 34,9 | Trunnion / 30x10 | 185 | 55 | 160 | 140 | 40 | 800 | 175 | - | 0,75 | |

STL CSL TTL HTL HTA STA BB WB ST RE SOH              

RIOT TRAIL FULL PARTY

| | STL | CSL | TTL | HTL | HTA | STA | BB | WB | ST | RE | SOH |  |  |  |  |  |  |  |  |  |  |  |  |  |  |
|----|-----|-----|-----|-----|-----|-----|------|------|-----|-----|-----|---|---|---|---|---|---|---|---|---|---|---|---|---|---|
| S | 417 | 446 | 580 | 90 | 64 | 77 | 38.1 | 1219 | 604 | 441 | 742 | 0 / 0 | 148/110 | 34,9 | Trunnion / 30x10 | 185 | 55 | 150 | 140 | 40 | 760 | 170 | - | 0,5 | |
| M | 441 | 446 | 614 | 110 | 64 | 77 | 38.1 | 1258 | 622 | 471 | 749 | 0 / 0 | 148/110 | 34,9 | Trunnion / 30x10 | 185 | 55 | 150 | 140 | 40 | 800 | 170 | - | 0,75 | |
| L | 465 | 455 | 646 | 140 | 64 | 77 | 33.3 | 1307 | 644 | 497 | 775 | 0 / 0 | 148/110 | 34,9 | Trunnion / 30x10 | 185 | 55 | 150 | 140 | 40 | 800 | 175 | - | 0,75 | |
| XL | 489 | 455 | 678 | 160 | 64 | 77 | 33.3 | 1346 | 662 | 527 | 793 | 0 / 0 | 148/110 | 34,9 | Trunnion / 30x10 | 185 | 55 | 150 | 140 | 40 | 800 | 175 | - | 0,75 | |

STL CSL TTL HTL HTA STA BB WB ST RE SOH              

RIOT TRAIL PRO

| | STL | CSL | TTL | HTL | HTA | STA | BB | WB | ST | RE | SOH |  |  |  |  |  |  |  |  |  |  |  |  |  |  |
|----|-----|-----|-----|-----|-----|-----|------|------|-----|-----|-----|---|---|---|---|---|---|---|---|---|---|---|---|---|---|
| S | 417 | 446 | 580 | 90 | 64 | 77 | 38.1 | 1219 | 604 | 441 | 742 | 0 / 0 | 148/110 | 34,9 | Trunnion / 30x10 | 185 | 55 | 150 | 140 | 40 | 760 | 170 | - | 0,5 | |
| M | 441 | 446 | 614 | 110 | 64 | 77 | 38.1 | 1258 | 622 | 471 | 749 | 0 / 0 | 148/110 | 34,9 | Trunnion / 30x10 | 185 | 55 | 150 | 140 | 40 | 800 | 170 | - | 0,75 | |
| L | 465 | 455 | 646 | 140 | 64 | 77 | 33.3 | 1307 | 644 | 497 | 775 | 0 / 0 | 148/110 | 34,9 | Trunnion / 30x10 | 185 | 55 | 150 | 140 | 40 | 800 | 175 | - | 0,75 | |
| XL | 489 | 455 | 679 | 160 | 64 | 77 | 33.3 | 1346 | 662 | 527 | 793 | 0 / 0 | 148/110 | 34,9 | Trunnion / 30x10 | 185 | 55 | 150 | 140 | 40 | 800 | 175 | - | 0,75 | |

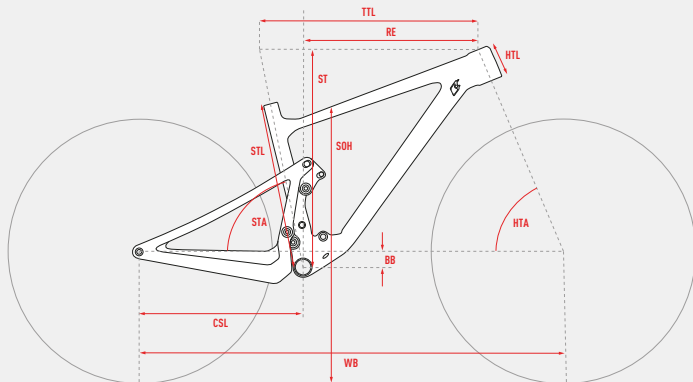

LECTOR FS



ALL DIMENSIONS IN MM (EXCEPT HTA AND STA IN °)

ALLE MASSE IN MM (AUSNAHME HTA UND STA IN °)

- STL** SEAT TUBE LENGTH
SITZROHRLÄNGE
- CSL** CHAINSTAY LENGTH
KETTENSTREBELÄNGE
- TTL** TOP TUBE LENGTH
OBERROHRLÄNGE
- HTL** HEAD TUBE LENGTH
STEUERROHRLÄNGE
- HTA** HEAD TUBE ANGLE
STEUERROHRWINKEL
- STA** SEAT TUBE ANGLE
SITZROHRWINKEL
- BB** BOTTOM BRACKET DROP
INNENLAGERABSENKUNG
- WB** WHEELBASE
RADSTAND
- ST** STACK
STACK
- RE** REACH
REACH
- SOH** STANDOVER HEIGHT
ÜBERSTANDSHÖHE
-  HEAD SET DIAMETER (UPPER / LOWER)
STEUERSATZDURCHMESSER (OBEN / UNTEN)
-  AXLE STANDARD (REAR / FRONT)
ACHSENSTANDARD (HINTEN / VORNE)
-  BOTTOM BRACKET STANDARD
TRETLAGERSTANDARD
-  SEAT POST DIAMETER
SITTELSTÜTZENDURCHMESSER
-  SHOCK HARDWARE (Ø 8 MM)
DÄMPFERBUCHSENMASSE (Ø 8 MM)
-  SHOCK LENGTH
DÄMPFEREINBAULÄNGE
-  SHOCK TRAVEL
DÄMPFERHUB
-  FRONT FORK TRAVEL
FEDERWEG VORNE
-  REAR WHEEL TRAVEL
FEDERWEG HINTEN
-  STEM LENGTH
VORBAULÄNGE
-  HANDLEBAR WIDTH
LENKERBREITE
-  CRANK LENGTH
KURBELLENGE
-  SEAT TUBE BOTTLE MOUNT
FLASCHE SITTELROHR
-  DOWNTUBE BOTTLE MOUNT
FLASCHE UNTERROHR

| | STL | CSL | TTL | HTL | HTA | STA | BB | WB | ST | RE | SOH |  |  |  |  |  |  |  |  |  |  |  |  |  |  | | |
|-------------------------------|-----|-----|-----|-----|-----|------|----|------|-----|-----|-----|---|---|---|---|---|---|---|---|---|---|---|---|---|---|--|--|
| LECTOR FS SF WORLD CUP | | | | | | | | | | | | | | | | | | | | | | | | | | | |
| XS | 417 | 435 | 575 | 90 | 68 | 75.5 | 41 | 1130 | 577 | 424 | 710 | 44 / 56 | 148/110 | PF92 / DUB | 34.9 | 30x10 / 54xTR | 165 | 40 | 100 | 100 | 50 | 700 | 170 | 0.5 | 0.75 | | |
| S | 441 | 435 | 603 | 90 | 68 | 75.5 | 41 | 1161 | 575 | 453 | 730 | 44 / 56 | 148/110 | PF92 / DUB | 34.9 | 30x10 / 54xTR | 165 | 40 | 100 | 100 | 50 | 720 | 170 | 0.5 | 0.75 | | |
| M | 465 | 440 | 649 | 100 | 68 | 75.5 | 33 | 1214 | 601 | 489 | 760 | 44 / 56 | 148/110 | PF92 / DUB | 34.9 | 30x10 / 54xTR | 165 | 45 | 120 | 120 | 50 | 740 | 170 | 0.75 | 0.75 | | |
| L | 489 | 440 | 669 | 120 | 68 | 75.5 | 33 | 1241 | 618 | 507 | 770 | 44 / 56 | 148/110 | PF92 / DUB | 34.9 | 30x10 / 54xTR | 165 | 45 | 120 | 120 | 50 | 740 | 175 | 0.75 | 0.75 | | |
| XL | 513 | 440 | 701 | 140 | 68 | 75.5 | 33 | 1275 | 636 | 533 | 780 | 44 / 56 | 148/110 | PF92 / DUB | 34.9 | 30x10 / 54xTR | 165 | 45 | 120 | 120 | 50 | 760 | 175 | 0.75 | 0.75 | | |

| | STL | CSL | TTL | HTL | HTA | STA | BB | WB | ST | RE | SOH |  |  |  |  |  |  |  |  |  |  |  |  |  |  | | |
|-------------------------|-----|-----|-----|-----|-----|------|----|------|-----|-----|-----|---|---|---|---|---|---|---|---|---|---|---|---|---|---|--|--|
| LECTOR FS SF PRO | | | | | | | | | | | | | | | | | | | | | | | | | | | |
| XS | 417 | 435 | 575 | 90 | 68 | 75.5 | 41 | 1130 | 577 | 424 | 710 | 44 / 56 | 148/110 | PF92 / DUB | 34.9 | 30x10 / 54xTR | 165 | 40 | 100 | 100 | 45 | 700 | 170 | 0.5 | 0.75 | | |
| S | 441 | 435 | 603 | 90 | 68 | 75.5 | 41 | 1161 | 575 | 453 | 730 | 44 / 56 | 148/110 | PF92 / DUB | 34.9 | 30x10 / 54xTR | 165 | 40 | 100 | 100 | 45 | 720 | 170 | 0.5 | 0.75 | | |
| M | 465 | 440 | 649 | 100 | 68 | 75.5 | 33 | 1214 | 601 | 489 | 760 | 44 / 56 | 148/110 | PF92 / DUB | 34.9 | 30x10 / 54xTR | 165 | 45 | 120 | 120 | 45 | 740 | 170 | 0.75 | 0.75 | | |
| L | 489 | 440 | 669 | 120 | 68 | 75.5 | 33 | 1241 | 618 | 507 | 770 | 44 / 56 | 148/110 | PF92 / DUB | 34.9 | 30x10 / 54xTR | 165 | 45 | 120 | 120 | 45 | 740 | 175 | 0.75 | 0.75 | | |
| XL | 513 | 440 | 701 | 140 | 68 | 75.5 | 33 | 1275 | 636 | 533 | 780 | 44 / 56 | 148/110 | PF92 / DUB | 34.9 | 30x10 / 54xTR | 165 | 45 | 120 | 120 | 45 | 760 | 175 | 0.75 | 0.75 | | |

| | STL | CSL | TTL | HTL | HTA | STA | BB | WB | ST | RE | SOH |  |  |  |  |  |  |  |  |  |  |  |  |  |  | | |
|------------------------------|-----|-----|-----|-----|-----|------|----|------|-----|-----|-----|---|---|---|---|---|---|---|---|---|---|---|---|---|---|--|--|
| LECTOR FS SF ADVANCED | | | | | | | | | | | | | | | | | | | | | | | | | | | |
| XS | 417 | 435 | 575 | 90 | 68 | 75.5 | 41 | 1130 | 577 | 424 | 710 | 44 / 56 | 148/110 | PF92 / DUB | 34.9 | 30x10 / 54xTR | 165 | 40 | 100 | 100 | 45 | 700 | 170 | 0.5 | 0.75 | | |
| S | 441 | 435 | 603 | 90 | 68 | 75.5 | 41 | 1161 | 575 | 453 | 730 | 44 / 56 | 148/110 | PF92 / DUB | 34.9 | 30x10 / 54xTR | 165 | 40 | 100 | 100 | 45 | 720 | 170 | 0.5 | 0.75 | | |
| M | 465 | 440 | 649 | 100 | 68 | 75.5 | 33 | 1214 | 601 | 489 | 760 | 44 / 56 | 148/110 | PF92 / DUB | 34.9 | 30x10 / 54xTR | 165 | 45 | 120 | 120 | 45 | 740 | 170 | 0.75 | 0.75 | | |
| L | 489 | 440 | 669 | 120 | 68 | 75.5 | 33 | 1241 | 618 | 507 | 770 | 44 / 56 | 148/110 | PF92 / DUB | 34.9 | 30x10 / 54xTR | 165 | 45 | 120 | 120 | 45 | 740 | 175 | 0.75 | 0.75 | | |
| XL | 513 | 440 | 701 | 140 | 68 | 75.5 | 33 | 1275 | 636 | 533 | 780 | 44 / 56 | 148/110 | PF92 / DUB | 34.9 | 30x10 / 54xTR | 165 | 45 | 120 | 120 | 45 | 760 | 175 | 0.75 | 0.75 | | |

LECTOR FS

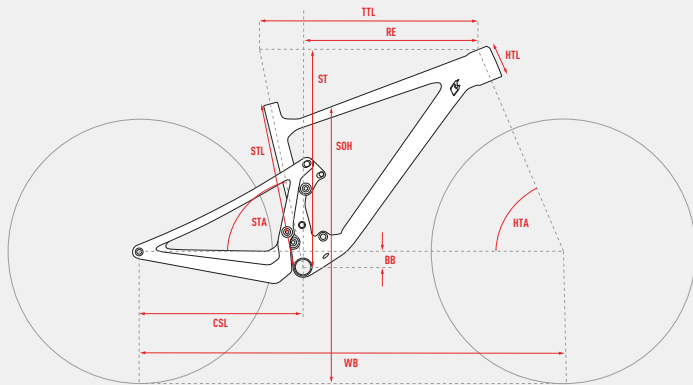







ALL DIMENSIONS IN MM (EXCEPT HTA AND STA IN °)

ALLE MASSE IN MM (AUSNAHME HTA UND STA IN °)

- STL** SEAT TUBE LENGTH
SITZROHRLÄNGE
- CSL** CHAINSTAY LENGTH
KETTENSTREBENLÄNGE
- TTL** TOP TUBE LENGTH
OBERROHRLÄNGE
- HTL** HEAD TUBE LENGTH
STEUERROHRLÄNGE
- HTA** HEAD TUBE ANGLE
STEUERROHRWINKEL
- STA** SEAT TUBE ANGLE
SITZROHRWINKEL
- BB** BOTTOM BRACKET DROP
INNENLAGERABSENKUNG
- WB** WHEELBASE
RADSTAND
- ST** STACK
STACK
- RE** REACH
REACH
- SOH** STANDOVER HEIGHT
ÜBERSTANDSHÖHE
-  HEAD SET DIAMETER (UPPER / LOWER)
STEUERSATZDURCHMESSER (OBEN / UNTEN)

-  AXLE STANDARD (REAR / FRONT)
ACHSENSTANDARD (HINTEN / VORNE)
-  BOTTOM BRACKET STANDARD
TRETLAGERSTANDARD
-  SEAT POST DIAMETER
SITTELSTÜTZENDURCHMESSER
-  SHOCK HARDWARE (Ø 8 MM)
DÄMPFERBUCHSENMASSE (Ø 8 MM)
-  SHOCK LENGTH
DÄMPFERENBAULÄNGE
-  SHOCK TRAVEL
DÄMPFERHUB
-  FRONT FORK TRAVEL
FEDERWEG VORNE
-  REAR WHEEL TRAVEL
FEDERWEG HINTEN
-  STEM LENGTH
VORBAULÄNGE
-  HANDLEBAR WIDTH
LENKERBREITE
-  CRANK LENGTH
KURBELLÄNGE
-  SEAT TUBE BOTTLE MOUNT
FLASCHE SITTELROHR
-  DOWNTUBE BOTTLE MOUNT
FLASCHE UNTERROHR

| | STL | CSL | TTL | HTL | HTA | STA | BB | WB | ST | RE | SOH |  |  |  |  |  |  |  |  |  |  |  |  |  |  | | |
|-------------------------------|-----|-----|-----|-----|-----|------|----|------|-----|-----|-----|---|---|---|---|---|---|---|---|---|---|---|---|---|---|--|--|
| LECTOR FS SF UNIVERSAL | | | | | | | | | | | | | | | | | | | | | | | | | | | |
| XS | 417 | 435 | 575 | 90 | 68 | 75.5 | 41 | 1130 | 577 | 424 | 710 | 44 / 56 | 148/110 | PF92 / DUB | 34.9 | 30x10 / 54xTR | 165 | 40 | 100 | 100 | 45 | 700 | 170 | 0.5 | 0.75 | | |
| S | 441 | 435 | 603 | 90 | 68 | 75.5 | 41 | 1161 | 575 | 453 | 730 | 44 / 56 | 148/110 | PF92 / DUB | 34.9 | 30x10 / 54xTR | 165 | 40 | 100 | 100 | 45 | 720 | 170 | 0.5 | 0.75 | | |
| M | 465 | 440 | 649 | 100 | 68 | 75.5 | 33 | 1214 | 601 | 489 | 760 | 44 / 56 | 148/110 | PF92 / DUB | 34.9 | 30x10 / 54xTR | 165 | 45 | 120 | 120 | 45 | 740 | 170 | 0.75 | 0.75 | | |
| L | 489 | 440 | 669 | 120 | 68 | 75.5 | 33 | 1241 | 618 | 507 | 770 | 44 / 56 | 148/110 | PF92 / DUB | 34.9 | 30x10 / 54xTR | 165 | 45 | 120 | 120 | 45 | 740 | 175 | 0.75 | 0.75 | | |
| XL | 513 | 440 | 701 | 140 | 68 | 75.5 | 33 | 1275 | 636 | 533 | 780 | 44 / 56 | 148/110 | PF92 / DUB | 34.9 | 30x10 / 54xTR | 165 | 45 | 120 | 120 | 45 | 760 | 175 | 0.75 | 0.75 | | |

| | STL | CSL | TTL | HTL | HTA | STA | BB | WB | ST | RE | SOH |  |  |  |  |  |  |  |  |  |  |  |  |  |  | | |
|-------------------------------|-----|-----|-----|-----|-----|------|----|------|-----|-----|-----|---|---|---|---|---|---|---|---|---|---|---|---|---|---|--|--|
| LECTOR FS SF ESSENTIAL | | | | | | | | | | | | | | | | | | | | | | | | | | | |
| XS | 417 | 435 | 575 | 90 | 68 | 75.5 | 41 | 1130 | 577 | 424 | 710 | 44 / 56 | 148/110 | PF92 / DUB | 34.9 | 30x10 / 54xTR | 165 | 40 | 100 | 100 | 45 | 700 | 170 | 0.5 | 0.75 | | |
| S | 441 | 435 | 603 | 90 | 68 | 75.5 | 41 | 1161 | 575 | 453 | 730 | 44 / 56 | 148/110 | PF92 / DUB | 34.9 | 30x10 / 54xTR | 165 | 40 | 100 | 100 | 45 | 720 | 170 | 0.5 | 0.75 | | |
| M | 465 | 440 | 649 | 100 | 68 | 75.5 | 33 | 1214 | 601 | 489 | 760 | 44 / 56 | 148/110 | PF92 / DUB | 34.9 | 30x10 / 54xTR | 165 | 45 | 120 | 120 | 45 | 740 | 170 | 0.75 | 0.75 | | |
| L | 489 | 440 | 669 | 120 | 68 | 75.5 | 33 | 1241 | 618 | 507 | 770 | 44 / 56 | 148/110 | PF92 / DUB | 34.9 | 30x10 / 54xTR | 165 | 45 | 120 | 120 | 45 | 740 | 175 | 0.75 | 0.75 | | |
| XL | 513 | 440 | 701 | 140 | 68 | 75.5 | 33 | 1275 | 636 | 533 | 780 | 44 / 56 | 148/110 | PF92 / DUB | 34.9 | 30x10 / 54xTR | 165 | 45 | 120 | 120 | 45 | 760 | 175 | 0.75 | 0.75 | | |

LECTOR

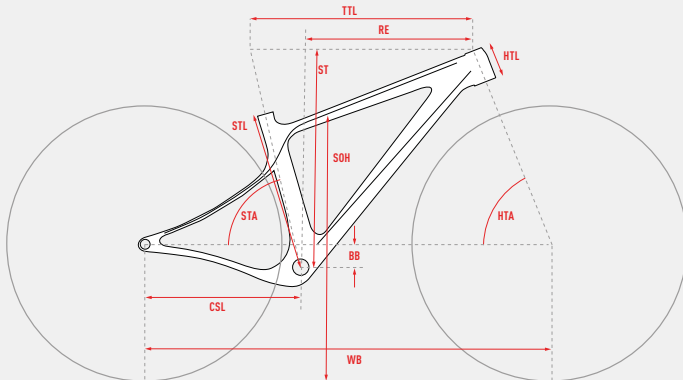

ALL DIMENSIONS IN MM (EXCEPT HTA AND STA IN °)

ALLE MASSE IN MM (AUSNAHME HTA UND STA IN °)

- STL** SEAT TUBE LENGTH
SITZROHRLÄNGE
- CSL** CHAINSTAY LENGTH
KETTENSTREBELÄNGE
- TTL** TOP TUBE LENGTH
OBERROHRLÄNGE
- HTL** HEAD TUBE LENGTH
STEUERROHRLÄNGE
- HTA** HEAD TUBE ANGLE
STEUERROHRWINKEL
- STA** SEAT TUBE ANGLE
SITZROHRWINKEL
- BB** BOTTOM BRACKET DROP
INNENLAGERABSENKUNG
- WB** WHEELBASE
RADSTAND
- ST** STACK
STACK
- RE** REACH
REACH
- SOH** STANDOVER HEIGHT
ÜBERSTANDSHÖHE
- HEAD SET DIAMETER (UPPER / LOWER)
STEUERSATZDURCHMESSER (OBEN / UNTEN)

- AXLE STANDARD (REAR / FRONT)
ACHSENSTANDARD (HINTEN / VORNE)
- BOTTOM BRACKET STANDARD
TRETLAGERSTANDARD
- SEAT POST DIAMETER
SÄTTELSTÜTZENDURCHMESSER
- SHOCK HARDWARE (Ø 8 MM)
DÄMPFERBUCHSENMASSE (Ø 8 MM)
- SHOCK LENGTH
DÄMPFEREINBAULÄNGE
- SHOCK TRAVEL
DÄMPFERHUB
- FRONT FORK TRAVEL
FEDERWEG VORNE
- REAR WHEEL TRAVEL
FEDERWEG HINTEN
- STEM LENGTH
VORBAULÄNGE
- HANDLEBAR WIDTH
LENKERBREITE
- CRANK LENGTH
KURBELLÄNGE
- SEAT TUBE BOTTLE MOUNT
FLASCHE SÄTTELROHR
- DOWNTUBE BOTTLE MOUNT
FLASCHE UNTERROHR

| | STL | CSL | TTL | HTL | HTA | STA | BB | WB | ST | RE | SOH | | | | | | | | | | | | | | |
|------------------------------------|-----|-----|-----|-----|-----|------|----|------|-----|-----|-----|---------|---------|------------|------|-------|---|---|-----|---|----|-----|-----|------|------|
| LECTOR SF WORLD CUP REPLICA | | | | | | | | | | | | | | | | | | | | | | | | | |
| XS | 393 | 430 | 582 | 90 | 68 | 73.7 | 65 | 1108 | 599 | 407 | 680 | 44 / 56 | 148/110 | PF92 / DUB | 34.9 | - / - | 0 | 0 | 100 | 0 | 45 | 700 | 170 | - | 0.75 |
| S | 417 | 430 | 617 | 90 | 68 | 73.7 | 65 | 1142 | 599 | 442 | 700 | 44 / 56 | 148/110 | PF92 / DUB | 34.9 | - / - | 0 | 0 | 100 | 0 | 45 | 720 | 170 | 0.5 | 0.75 |
| M | 441 | 430 | 652 | 90 | 68 | 73.7 | 65 | 1177 | 599 | 477 | 720 | 44 / 56 | 148/110 | PF92 / DUB | 34.9 | - / - | 0 | 0 | 100 | 0 | 45 | 740 | 170 | 0.75 | 0.75 |
| L | 465 | 430 | 683 | 110 | 68 | 73.7 | 60 | 1214 | 635 | 497 | 745 | 44 / 56 | 148/110 | PF92 / DUB | 34.9 | - / - | 0 | 0 | 120 | 0 | 45 | 740 | 175 | 0.75 | 0.75 |
| XL | 489 | 430 | 715 | 140 | 68 | 73.7 | 60 | 1249 | 663 | 521 | 770 | 44 / 56 | 148/110 | PF92 / DUB | 34.9 | - / - | 0 | 0 | 120 | 0 | 45 | 760 | 175 | 0.75 | 0.75 |

| | STL | CSL | TTL | HTL | HTA | STA | BB | WB | ST | RE | SOH | | | | | | | | | | | | | | |
|---------------------------|-----|-----|-----|-----|-----|------|----|------|-----|-----|-----|---------|---------|------------|------|-------|---|---|-----|---|----|-----|-----|------|------|
| LECTOR SF ADVANCED | | | | | | | | | | | | | | | | | | | | | | | | | |
| XS | 393 | 430 | 582 | 90 | 68 | 73.7 | 65 | 1108 | 599 | 407 | 680 | 44 / 56 | 148/110 | PF92 / DUB | 34.9 | - / - | 0 | 0 | 100 | 0 | 45 | 700 | 170 | - | 0.75 |
| S | 417 | 430 | 617 | 90 | 68 | 73.7 | 65 | 1142 | 599 | 442 | 700 | 44 / 56 | 148/110 | PF92 / DUB | 34.9 | - / - | 0 | 0 | 100 | 0 | 45 | 720 | 170 | 0.5 | 0.75 |
| M | 441 | 430 | 652 | 90 | 68 | 73.7 | 65 | 1177 | 599 | 477 | 720 | 44 / 56 | 148/110 | PF92 / DUB | 34.9 | - / - | 0 | 0 | 100 | 0 | 45 | 740 | 170 | 0.75 | 0.75 |
| L | 465 | 430 | 683 | 110 | 68 | 73.7 | 60 | 1214 | 635 | 497 | 745 | 44 / 56 | 148/110 | PF92 / DUB | 34.9 | - / - | 0 | 0 | 120 | 0 | 45 | 740 | 175 | 0.75 | 0.75 |
| XL | 489 | 430 | 715 | 140 | 68 | 73.7 | 60 | 1249 | 663 | 521 | 770 | 44 / 56 | 148/110 | PF92 / DUB | 34.9 | - / - | 0 | 0 | 120 | 0 | 45 | 760 | 175 | 0.75 | 0.75 |

| | STL | CSL | TTL | HTL | HTA | STA | BB | WB | ST | RE | SOH | | | | | | | | | | | | | | |
|----------------------------|-----|-----|-----|-----|-----|------|----|------|-----|-----|-----|---------|---------|------------|------|-------|---|---|-----|---|----|-----|-----|------|------|
| LECTOR SF UNIVERSAL | | | | | | | | | | | | | | | | | | | | | | | | | |
| XS | 393 | 430 | 582 | 90 | 68 | 73.7 | 65 | 1108 | 599 | 407 | 680 | 44 / 56 | 148/110 | PF92 / DUB | 34.9 | - / - | 0 | 0 | 100 | 0 | 45 | 700 | 170 | - | 0.75 |
| S | 417 | 430 | 617 | 90 | 68 | 73.7 | 65 | 1142 | 599 | 442 | 700 | 44 / 56 | 148/110 | PF92 / DUB | 34.9 | - / - | 0 | 0 | 100 | 0 | 45 | 720 | 170 | 0.5 | 0.75 |
| M | 441 | 430 | 652 | 90 | 68 | 73.7 | 65 | 1177 | 599 | 477 | 720 | 44 / 56 | 148/110 | PF92 / DUB | 34.9 | - / - | 0 | 0 | 100 | 0 | 45 | 740 | 170 | 0.75 | 0.75 |
| L | 465 | 430 | 683 | 110 | 68 | 73.7 | 60 | 1214 | 635 | 497 | 745 | 44 / 56 | 148/110 | PF92 / DUB | 34.9 | - / - | 0 | 0 | 120 | 0 | 45 | 740 | 175 | 0.75 | 0.75 |
| XL | 489 | 430 | 715 | 140 | 68 | 73.7 | 60 | 1249 | 663 | 521 | 770 | 44 / 56 | 148/110 | PF92 / DUB | 34.9 | - / - | 0 | 0 | 120 | 0 | 45 | 760 | 175 | 0.75 | 0.75 |

| | STL | CSL | TTL | HTL | HTA | STA | BB | WB | ST | RE | SOH | | | | | | | | | | | | | | |
|----------------------------|-----|-----|-----|-----|-----|------|----|------|-----|-----|-----|---------|---------|------------|------|-------|---|---|-----|---|----|-----|-----|------|------|
| LECTOR SF ESSENTIAL | | | | | | | | | | | | | | | | | | | | | | | | | |
| XS | 393 | 430 | 582 | 90 | 68 | 73.7 | 65 | 1108 | 599 | 407 | 680 | 44 / 56 | 148/110 | PF92 / DUB | 34.9 | - / - | 0 | 0 | 100 | 0 | 45 | 700 | 170 | - | 0.75 |
| S | 417 | 430 | 617 | 90 | 68 | 73.7 | 65 | 1142 | 599 | 442 | 700 | 44 / 56 | 148/110 | PF92 / DUB | 34.9 | - / - | 0 | 0 | 100 | 0 | 45 | 720 | 170 | 0.5 | 0.75 |
| M | 441 | 430 | 652 | 90 | 68 | 73.7 | 65 | 1177 | 599 | 477 | 720 | 44 / 56 | 148/110 | PF92 / DUB | 34.9 | - / - | 0 | 0 | 100 | 0 | 45 | 740 | 170 | 0.75 | 0.75 |
| L | 465 | 430 | 683 | 110 | 68 | 73.7 | 60 | 1214 | 635 | 497 | 745 | 44 / 56 | 148/110 | PF92 / DUB | 34.9 | - / - | 0 | 0 | 120 | 0 | 45 | 740 | 175 | 0.75 | 0.75 |
| XL | 489 | 430 | 715 | 140 | 68 | 73.7 | 60 | 1249 | 663 | 521 | 770 | 44 / 56 | 148/110 | PF92 / DUB | 34.9 | - / - | 0 | 0 | 120 | 0 | 45 | 760 | 175 | 0.75 | 0.75 |

| | STL | CSL | TTL | HTL | HTA | STA | BB | WB | ST | RE | SOH | | | | | | | | | | | | | | |
|------------------|-----|-----|-----|-----|-----|------|----|------|-----|-----|-----|---------|---------|------------|------|-------|---|---|-----|---|----|-----|-----|------|------|
| LECTOR SF | | | | | | | | | | | | | | | | | | | | | | | | | |
| XS | 393 | 430 | 582 | 90 | 68 | 73.7 | 65 | 1108 | 599 | 407 | 680 | 44 / 56 | 148/110 | PF92 / DUB | 34.9 | - / - | 0 | 0 | 100 | 0 | 45 | 700 | 170 | - | 0.75 |
| S | 417 | 430 | 617 | 90 | 68 | 73.7 | 65 | 1142 | 599 | 442 | 700 | 44 / 56 | 148/110 | PF92 / DUB | 34.9 | - / - | 0 | 0 | 100 | 0 | 45 | 720 | 170 | 0.5 | 0.75 |
| M | 441 | 430 | 652 | 90 | 68 | 73.7 | 65 | 1177 | 599 | 477 | 720 | 44 / 56 | 148/110 | PF92 / DUB | 34.9 | - / - | 0 | 0 | 100 | 0 | 45 | 740 | 170 | 0.75 | 0.75 |
| L | 465 | 430 | 683 | 110 | 68 | 73.7 | 60 | 1214 | 635 | 497 | 745 | 44 / 56 | 148/110 | PF92 / DUB | 34.9 | - / - | 0 | 0 | 120 | 0 | 45 | 740 | 175 | 0.75 | 0.75 |
| XL | 489 | 430 | 715 | 140 | 68 | 73.7 | 60 | 1249 | 663 | 521 | 770 | 44 / 56 | 148/110 | PF92 / DUB | 34.9 | - / - | 0 | 0 | 120 | 0 | 45 | 760 | 175 | 0.75 | 0.75 |

NIRVANA TRAIL

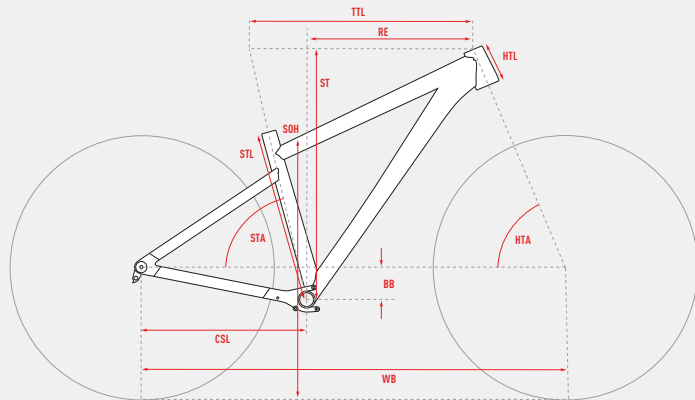

ALL DIMENSIONS IN MM (EXCEPT HTA AND STA IN °)

ALLE MASSE IN MM (AUSNAHME HTA UND STA IN °)

- STL** SEAT TUBE LENGTH
SITZROHRLÄNGE
- CSL** CHAINSTAY LENGTH
KETTENSTREBENLÄNGE
- TTL** TOP TUBE LENGTH
OBERROHRLÄNGE
- HTL** HEAD TUBE LENGTH
STEUERROHRLÄNGE
- HTA** HEAD TUBE ANGLE
STEUERROHRWINKEL
- STA** SEAT TUBE ANGLE
SITZROHRWINKEL
- BB** BOTTOM BRACKET DROP
INNENLAGERABSENKUNG
- WB** WHEELBASE
RADSTAND
- ST** STACK
STACK
- RE** REACH
REACH
- SOH** STANDOVER HEIGHT
ÜBERSTANDSHÖHE
- HEAD SET DIAMETER (UPPER / LOWER)
STEUERSATZDURCHMESSER (OBEN / UNTEN)
- AXLE STANDARD (REAR / FRONT)
ACHSENSTANDARD (HINTEN / VORNE)
- BOTTOM BRACKET STANDARD
TRETLAGERSTANDARD
- SEAT POST DIAMETER
SATTELSTÜTZENDURCHMESSER
- SHOCK HARDWARE (Ø 8 MM)
DÄMPFERBUCHSENMASSE (Ø 8 MM)
- SHOCK LENGTH
DÄMPFERENBAULÄNGE
- SHOCK TRAVEL
DÄMPFERHUB
- FRONT FORK TRAVEL
FEDERWEG VORNE
- REAR WHEEL TRAVEL
FEDERWEG HINTEN
- STEM LENGTH
VORBAULÄNGE
- HANDLEBAR WIDTH
LENKERBREITE
- CRANK LENGTH
KURBELLÄNGE
- SEAT TUBE BOTTLE MOUNT
FLASCHE SATTELROHR
- DOWNTUBE BOTTLE MOUNT
FLASCHE UNTERROHR

| | STL | CSL | TTL | HTL | HTA | STA | BB | WB | ST | RE | SOH | | | | | | | | | | | | | | | |
|--------------------------------|-----|-----|-----|-----|-----|------|----|------|-----|-----|-----|---------|---------|--------|------|-------|---|---|-----|---|----|-----|-----|---|------|--|
| NIRVANA TRAIL UNIVERSAL | | | | | | | | | | | | | | | | | | | | | | | | | | |
| S | 417 | 405 | 580 | 100 | 66 | 74.6 | 58 | 1128 | 618 | 427 | 710 | 44 / 56 | 148/110 | BSA 73 | 34.9 | - / - | 0 | 0 | 140 | 0 | 45 | 700 | 170 | - | 0.75 | |
| M | 441 | 425 | 600 | 100 | 66 | 74.6 | 71 | 1177 | 645 | 441 | 728 | 44 / 56 | 148/110 | BSA 73 | 34.9 | - / - | 0 | 0 | 140 | 0 | 45 | 720 | 170 | - | 0.75 | |
| L | 465 | 425 | 629 | 140 | 66 | 74.6 | 66 | 1215 | 677 | 462 | 764 | 44 / 56 | 148/110 | BSA 73 | 34.9 | - / - | 0 | 0 | 140 | 0 | 45 | 740 | 170 | - | 0.75 | |
| XL | 489 | 425 | 659 | 160 | 66 | 74.6 | 66 | 1251 | 695 | 490 | 784 | 44 / 56 | 148/110 | BSA 73 | 34.9 | - / - | 0 | 0 | 140 | 0 | 45 | 760 | 175 | - | 0.75 | |

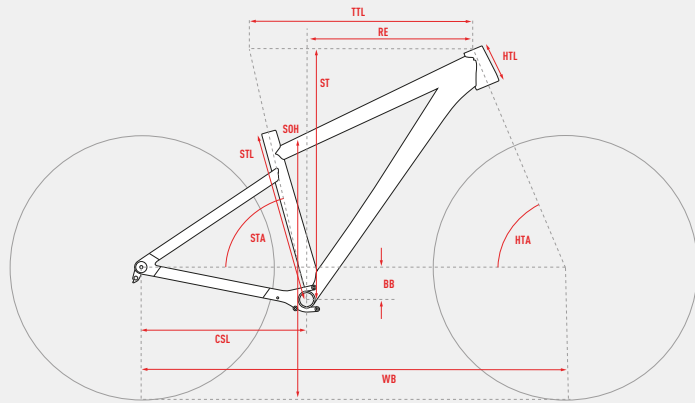

NIRVANA TOUR



ALL DIMENSIONS IN MM (EXCEPT HTA AND STA IN °)

ALLE MASSE IN MM (AUSNAHME HTA UND STA IN °)

- STL** SEAT TUBE LENGTH
SITZROHRLÄNGE
- CSL** CHAINSTAY LENGTH
KETTENSTREBENLÄNGE
- TTL** TOP TUBE LENGTH
OBERROHRLÄNGE
- HTL** HEAD TUBE LENGTH
STEUERROHRLÄNGE
- HTA** HEAD TUBE ANGLE
STEUERROHRWINKEL
- STA** SEAT TUBE ANGLE
SITZROHRWINKEL
- BB** BOTTOM BRACKET DROP
INNENLAGERABSENKUNG
- WB** WHEELBASE
RADSTAND
- ST** STACK
STACK
- RE** REACH
REACH
- SOH** STANDOVER HEIGHT
ÜBERSTANDSHÖHE
-  **HEAD SET DIAMETER (UPPER / LOWER)**
STEUERSATZDURCHMESSER (OBEN / UNTEN)

-  **AXLE STANDARD (REAR / FRONT)**
ACHSENSTANDARD (HINTEN / VORNE)
-  **BOTTOM BRACKET STANDARD**
TRETLAGERSTANDARD
-  **SEAT POST DIAMETER**
SÄTTELSTÜTZENDURCHMESSER
-  **SHOCK HARDWARE (Ø 8 MM)**
DÄMPFERBUCHSENMASSE (Ø 8 MM)
-  **SHOCK LENGTH**
DÄMPFEREINBAULÄNGE
-  **SHOCK TRAVEL**
DÄMPFERHUB
-  **FRONT FORK TRAVEL**
FEDERWEG VORNE
-  **REAR WHEEL TRAVEL**
FEDERWEG HINTEN
-  **STEM LENGTH**
VORBAULÄNGE
-  **HANDLEBAR WIDTH**
LENKERBREITE
-  **CRANK LENGTH**
KURBELLÄNGE
-  **SEAT TUBE BOTTLE MOUNT**
FLASCHE SÄTTELROHR
-  **DOWNTUBE BOTTLE MOUNT**
FLASCHE UNTERROHR

| | STL | CSL | TTL | HTL | HTA | STA | BB | WB | ST | RE | SOH |  |  |  |  |  |  |  |  |  |  |  |  |  |  | | |
|-------------------------------|-----|-----|-----|-----|------|------|------|------|-----|-----|-----|---|---|---|---|---|---|---|---|---|---|---|---|---|---|--|--|
| NIRVANA TOUR UNIVERSAL | | | | | | | | | | | | | | | | | | | | | | | | | | | |
| XS | 393 | 405 | 568 | 100 | 65.6 | 72.1 | 51 | 1067 | 586 | 379 | 679 | 44 / 56 | 148/110 | BSA 73 | 34.9 | - / - | 0 | 0 | 100 | 0 | 45 | 700 | 170 | - | 0.75 | | |
| S | 417 | 405 | 592 | 100 | 67.5 | 74 | 64.5 | 1093 | 609 | 417 | 699 | 44 / 56 | 148/110 | BSA 73 | 34.9 | - / - | 0 | 0 | 120 | 0 | 45 | 700 | 170 | - | 0.75 | | |
| M | 441 | 425 | 612 | 100 | 67.5 | 74 | 84 | 1140 | 643 | 428 | 717 | 44 / 56 | 148/110 | BSA 73 | 34.9 | - / - | 0 | 0 | 120 | 0 | 45 | 720 | 170 | - | 0.75 | | |
| L | 465 | 425 | 645 | 120 | 67.5 | 74 | 79 | 1176 | 656 | 457 | 735 | 44 / 56 | 148/110 | BSA 73 | 34.9 | - / - | 0 | 0 | 120 | 0 | 45 | 740 | 170 | - | 0.75 | | |
| XL | 489 | 425 | 677 | 140 | 67.5 | 74 | 74 | 1212 | 670 | 485 | 756 | 44 / 56 | 148/110 | BSA 73 | 34.9 | - / - | 0 | 0 | 120 | 0 | 45 | 760 | 175 | - | 0.75 | | |

| | STL | CSL | TTL | HTL | HTA | STA | BB | WB | ST | RE | SOH |  |  |  |  |  |  |  |  |  |  |  |  |  |  | | |
|-------------------------------|-----|-----|-----|-----|------|------|------|------|-----|-----|-----|---|---|---|---|---|---|---|---|---|---|---|---|---|---|--|--|
| NIRVANA TOUR ESSENTIAL | | | | | | | | | | | | | | | | | | | | | | | | | | | |
| XS | 393 | 405 | 568 | 100 | 65.6 | 72.1 | 51 | 1067 | 586 | 379 | 679 | 44 / 56 | 148/110 | BSA 73 | 34.9 | - / - | 0 | 0 | 100 | 0 | 45 | 700 | 170 | - | 0.75 | | |
| S | 417 | 405 | 592 | 100 | 67.5 | 74 | 64.5 | 1093 | 609 | 417 | 699 | 44 / 56 | 148/110 | BSA 73 | 34.9 | - / - | 0 | 0 | 120 | 0 | 45 | 700 | 170 | - | 0.75 | | |
| M | 441 | 425 | 612 | 100 | 67.5 | 74 | 84 | 1140 | 643 | 428 | 717 | 44 / 56 | 148/110 | BSA 73 | 34.9 | - / - | 0 | 0 | 120 | 0 | 45 | 720 | 170 | - | 0.75 | | |
| L | 465 | 425 | 645 | 120 | 67.5 | 74 | 79 | 1176 | 656 | 457 | 735 | 44 / 56 | 148/110 | BSA 73 | 34.9 | - / - | 0 | 0 | 120 | 0 | 45 | 740 | 170 | - | 0.75 | | |
| XL | 489 | 425 | 677 | 140 | 67.5 | 74 | 74 | 1212 | 670 | 485 | 756 | 44 / 56 | 148/110 | BSA 73 | 34.9 | - / - | 0 | 0 | 120 | 0 | 45 | 760 | 175 | - | 0.75 | | |

| | STL | CSL | TTL | HTL | HTA | STA | BB | WB | ST | RE | SOH |  |  |  |  |  |  |  |  |  |  |  |  |  |  | | |
|---------------------|-----|-----|-----|-----|------|------|------|------|-----|-----|-----|---|---|---|---|---|---|---|---|---|---|---|---|---|---|--|--|
| NIRVANA TOUR | | | | | | | | | | | | | | | | | | | | | | | | | | | |
| XS | 393 | 405 | 568 | 100 | 65.6 | 72.1 | 51 | 1067 | 586 | 379 | 679 | 44 / 56 | 148/110 | BSA 73 | 34.9 | - / - | 0 | 0 | 100 | 0 | 45 | 700 | 170 | - | 0.75 | | |
| S | 417 | 405 | 592 | 100 | 67.5 | 74 | 64.5 | 1093 | 609 | 417 | 699 | 44 / 56 | 148/110 | BSA 73 | 34.9 | - / - | 0 | 0 | 120 | 0 | 45 | 700 | 170 | - | 0.75 | | |
| M | 441 | 425 | 612 | 100 | 67.5 | 74 | 84 | 1140 | 643 | 428 | 717 | 44 / 56 | 148/110 | BSA 73 | 34.9 | - / - | 0 | 0 | 120 | 0 | 45 | 720 | 170 | - | 0.75 | | |
| L | 465 | 425 | 645 | 120 | 67.5 | 74 | 79 | 1176 | 656 | 457 | 735 | 44 / 56 | 148/110 | BSA 73 | 34.9 | - / - | 0 | 0 | 120 | 0 | 45 | 740 | 170 | - | 0.75 | | |
| XL | 489 | 425 | 677 | 140 | 67.5 | 74 | 74 | 1212 | 670 | 485 | 756 | 44 / 56 | 148/110 | BSA 73 | 34.9 | - / - | 0 | 0 | 120 | 0 | 45 | 760 | 175 | - | 0.75 | | |



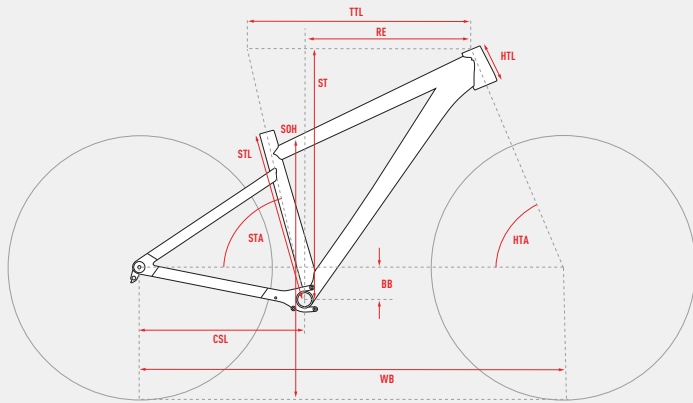









NIRVANA 4X



ALL DIMENSIONS IN MM (EXCEPT HTA AND STA IN °)

ALLE MASSE IN MM (AUSNAHME HTA UND STA IN °)

- STL** SEAT TUBE LENGTH
SITZROHRLÄNGE
- CSL** CHAINSTAY LENGTH
KETTENSTREBENLÄNGE
- TTL** TOP TUBE LENGTH
OBERROHRLÄNGE
- HTL** HEAD TUBE LENGTH
STEUERROHRLÄNGE
- HTA** HEAD TUBE ANGLE
STEUERROHRWINKEL
- STA** SEAT TUBE ANGLE
SITZROHRWINKEL
- BB** BOTTOM BRACKET DROP
INNENLAGERABSENKUNG
- WB** WHEELBASE
RADSTAND
- ST** STACK
STACK
- RE** REACH
REACH
- SOH** STANDOVER HEIGHT
ÜBERSTANDSHÖHE
-  HEAD SET DIAMETER (UPPER / LOWER)
STEUERSATZDURCHMESSER (OBEN / UNTEN)
-  AXLE STANDARD (REAR / FRONT)
ACHSENSTANDARD (HINTEN / VORNE)
-  BOTTOM BRACKET STANDARD
TRETLAGERSTANDARD
-  SEAT POST DIAMETER
SÄTTELSTÜTZENDURCHMESSER
-  SHOCK HARDWARE (Ø 8 MM)
DÄMPFERBUCHSENMASSE (Ø 8 MM)
-  SHOCK LENGTH
DÄMPFERENBAULÄNGE
-  SHOCK TRAVEL
DÄMPFERHUB
-  FRONT FORK TRAVEL
FEDERWEG VORNE
-  REAR WHEEL TRAVEL
FEDERWEG HINTEN
-  STEM LENGTH
VORBAULÄNGE
-  HANDLEBAR WIDTH
LENKERBREITE
-  CRANK LENGTH
KURBELLÄNGE
-  SEAT TUBE BOTTLE MOUNT
FLASCHE SÄTTELROHR
-  DOWNTUBE BOTTLE MOUNT
FLASCHE UNTERROHR

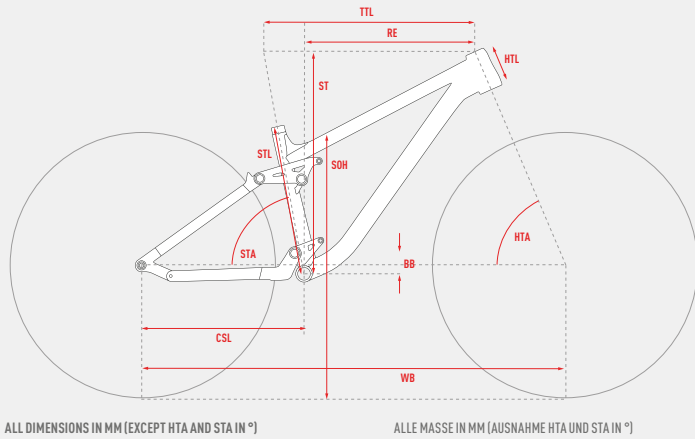

| | STL | CSL | TTL | HTL | HTA | STA | BB | WB | ST | RE | SOH |  |  |  |  |  |  |  |  |  |  |  |  |  |  | | | |
|-------------------|-----|-----|-----|-----|-----|------|----|------|-----|-----|-----|---|---|---|---|---|---|---|---|---|---|---|---|---|---|--|--|--|
| NIRVANA 4X | | | | | | | | | | | | | | | | | | | | | | | | | | | | |
| M | 340 | 415 | 561 | 120 | 68 | 74.6 | 28 | 1093 | 571 | 415 | 666 | 44/56 | 148/110 | BSA.73 | 34.9 | -/- | 0 | 0 | 100 | 0 | 45 | 780 | 175 | - | 0.75 | | | |



ALL DIMENSIONS IN MM (EXCEPT HTA AND STA IN °)

ALLE MASSE IN MM (AUSNAHME HTA UND STA IN °)

- STL** SEAT TUBE LENGTH
SITZROHRLÄNGE
- CSL** CHAINSTAY LENGTH
KETTENSTREBENLÄNGE
- TTL** TOP TUBE LENGTH
OBERROHRLÄNGE
- HTL** HEAD TUBE LENGTH
STEUERROHRLÄNGE
- HTA** HEAD TUBE ANGLE
STEUERROHRWINKEL
- STA** SEAT TUBE ANGLE
SITZROHRWINKEL
- BB** BOTTOM BRACKET DROP
INNENLAGERABSENKUNG
- WB** WHEELBASE
RADSTAND
- ST** STACK
STACK
- RE** REACH
REACH
- SOH** STANDOVER HEIGHT
ÜBERSTANDSHÖHE
-  HEAD SET DIAMETER (UPPER / LOWER)
STEUERSATZDURCHMESSER (OBEN / UNTEN)

-  AXLE STANDARD (REAR / FRONT)
ACHSENSTANDARD (HINTEN / VORNE)
-  BOTTOM BRACKET STANDARD
TRETLAGERSTANDARD
-  SEAT POST DIAMETER
SÄTTELSTÜTZENDURCHMESSER
-  SHOCK HARDWARE (Ø 8 MM)
DÄMPFERBUCHSENMASSE (Ø 8 MM)
-  SHOCK LENGTH
DÄMPFERENBAULÄNGE
-  SHOCK TRAVEL
DÄMPFERHUB
-  FRONT FORK TRAVEL
FEDERWEG VORNE
-  REAR WHEEL TRAVEL
FEDERWEG HINTEN
-  STEM LENGTH
VORBAULÄNGE
-  HANDLEBAR WIDTH
LENKERBREITE
-  CRANK LENGTH
KURBELLÄNGE
-  SEAT TUBE BOTTLE MOUNT
FLASCHE SÄTTELROHR
-  DOWNTUBE BOTTLE MOUNT
FLASCHE UNTERROHR

| | STL | CSL | TTL | HTL | HTA | STA | BB | WB | ST | RE | SOH |  |  |  |  |  |  |  |  |  |  |  |  |  |  | | |
|--------------------------|-----|-----|-----|-----|-----|-----|----|------|-----|-----|-----|---|---|---|---|---|---|---|---|---|---|---|---|---|---|--|--|
| KATO FS UNIVERSAL | | | | | | | | | | | | | | | | | | | | | | | | | | | |
| XS | 385 | 430 | 550 | 100 | 66 | 77 | 22 | 1145 | 578 | 419 | 698 | 44 / 56 | 148/110 | BSA 73 | 31.6 | 30 / 30 | 210 | 50 | 130 | 130 | 50 | 700 | 170 | - | 0.75 | | |
| S | 395 | 430 | 586 | 110 | 66 | 77 | 22 | 1181 | 587 | 451 | 700 | 44 / 56 | 148/110 | BSA 73 | 31.6 | 30 / 30 | 210 | 50 | 130 | 130 | 50 | 720 | 170 | - | 0.75 | | |
| M | 415 | 450 | 606 | 120 | 66 | 77 | 36 | 1231 | 625 | 463 | 715 | 44 / 56 | 148/110 | BSA 73 | 31.6 | 30 / 30 | 210 | 50 | 130 | 130 | 50 | 740 | 175 | 0.4 | 0.75 | | |
| L | 435 | 450 | 641 | 135 | 66 | 77 | 36 | 1268 | 639 | 494 | 726 | 44 / 56 | 148/110 | BSA 73 | 31.6 | 30 / 30 | 210 | 50 | 130 | 130 | 50 | 740 | 175 | 0.4 | 0.75 | | |
| XL | 465 | 450 | 674 | 160 | 66 | 77 | 36 | 1305 | 662 | 521 | 744 | 44 / 56 | 148/110 | BSA 73 | 31.6 | 30 / 30 | 210 | 50 | 130 | 130 | 50 | 780 | 175 | 0.4 | 0.75 | | |

| | STL | CSL | TTL | HTL | HTA | STA | BB | WB | ST | RE | SOH |  |  |  |  |  |  |  |  |  |  |  |  |  |  | | |
|--------------------------|-----|-----|-----|-----|-----|-----|----|------|-----|-----|-----|---|---|---|---|---|---|---|---|---|---|---|---|---|---|--|--|
| KATO FS ESSENTIAL | | | | | | | | | | | | | | | | | | | | | | | | | | | |
| XS | 385 | 430 | 550 | 100 | 66 | 77 | 22 | 1145 | 578 | 419 | 698 | 44 / 56 | 148/110 | BSA 73 | 31.6 | 30 / 30 | 210 | 50 | 130 | 130 | 50 | 700 | 170 | - | 0.75 | | |
| S | 395 | 430 | 586 | 110 | 66 | 77 | 22 | 1181 | 587 | 451 | 700 | 44 / 56 | 148/110 | BSA 73 | 31.6 | 30 / 30 | 210 | 50 | 130 | 130 | 50 | 720 | 170 | - | 0.75 | | |
| M | 415 | 450 | 606 | 120 | 66 | 77 | 36 | 1231 | 625 | 463 | 715 | 44 / 56 | 148/110 | BSA 73 | 31.6 | 30 / 30 | 210 | 50 | 130 | 130 | 50 | 740 | 175 | 0.4 | 0.75 | | |
| L | 435 | 450 | 641 | 135 | 66 | 77 | 36 | 1268 | 639 | 494 | 726 | 44 / 56 | 148/110 | BSA 73 | 31.6 | 30 / 30 | 210 | 50 | 130 | 130 | 50 | 740 | 175 | 0.4 | 0.75 | | |
| XL | 465 | 450 | 674 | 160 | 66 | 77 | 36 | 1305 | 662 | 521 | 744 | 44 / 56 | 148/110 | BSA 73 | 31.6 | 30 / 30 | 210 | 50 | 130 | 130 | 50 | 780 | 175 | 0.4 | 0.75 | | |

| | STL | CSL | TTL | HTL | HTA | STA | BB | WB | ST | RE | SOH |  |  |  |  |  |  |  |  |  |  |  |  |  |  | | |
|----------------|-----|-----|-----|-----|-----|-----|----|------|-----|-----|-----|---|---|---|---|---|---|---|---|---|---|---|---|---|---|--|--|
| KATO FS | | | | | | | | | | | | | | | | | | | | | | | | | | | |
| XS | 385 | 430 | 550 | 100 | 66 | 77 | 22 | 1145 | 578 | 419 | 698 | 44 / 56 | 148/110 | BSA 73 | 31.6 | 30 / 30 | 210 | 50 | 130 | 130 | 50 | 700 | 170 | - | 0.75 | | |
| S | 395 | 430 | 586 | 110 | 66 | 77 | 22 | 1181 | 587 | 451 | 700 | 44 / 56 | 148/110 | BSA 73 | 31.6 | 30 / 30 | 210 | 50 | 130 | 130 | 50 | 720 | 170 | - | 0.75 | | |
| M | 415 | 450 | 606 | 120 | 66 | 77 | 36 | 1231 | 625 | 463 | 715 | 44 / 56 | 148/110 | BSA 73 | 31.6 | 30 / 30 | 210 | 50 | 130 | 130 | 50 | 740 | 175 | 0.4 | 0.75 | | |
| L | 435 | 450 | 641 | 135 | 66 | 77 | 36 | 1268 | 639 | 494 | 726 | 44 / 56 | 148/110 | BSA 73 | 31.6 | 30 / 30 | 210 | 50 | 130 | 130 | 50 | 740 | 175 | 0.4 | 0.75 | | |
| XL | 465 | 450 | 674 | 160 | 66 | 77 | 36 | 1305 | 662 | 521 | 744 | 44 / 56 | 148/110 | BSA 73 | 31.6 | 30 / 30 | 210 | 50 | 130 | 130 | 50 | 780 | 175 | 0.4 | 0.75 | | |



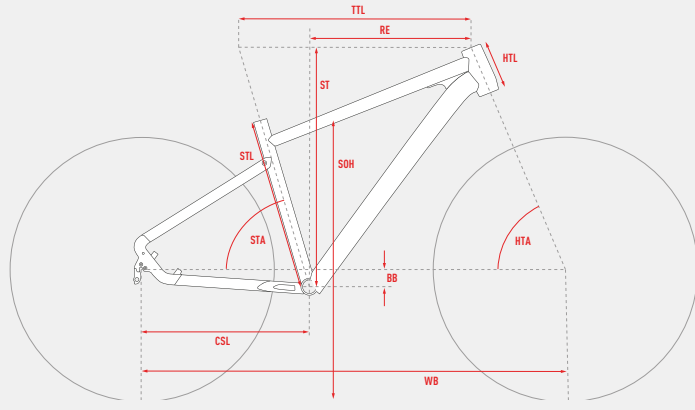











KATO



ALL DIMENSIONS IN MM (EXCEPT HTA AND STA IN °)

ALLE MASSE IN MM (AUSNAHME HTA UND STA IN °)







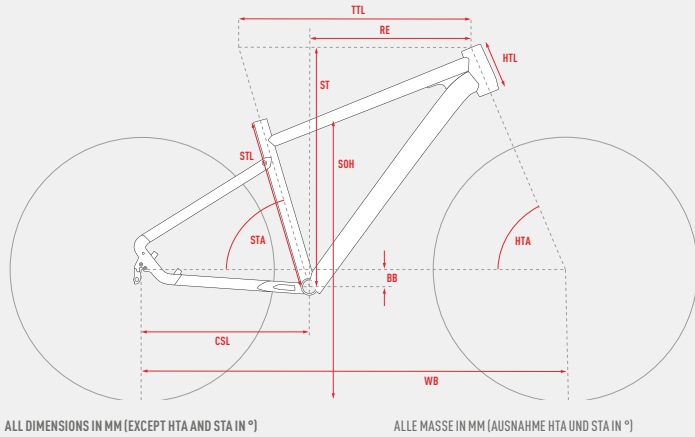





- STL** SEAT TUBE LENGTH
SITZROHRLÄNGE
- CSL** CHAINSTAY LENGTH
KETTENSTREBELÄNGE
- TTL** TOP TUBE LENGTH
OBERROHRLÄNGE
- HTL** HEAD TUBE LENGTH
STEUERROHRLÄNGE
- HTA** HEAD TUBE ANGLE
STEUERROHRWINKEL
- STA** SEAT TUBE ANGLE
SITZROHRWINKEL
- BB** BOTTOM BRACKET DROP
INNENLAGERABSENKUNG
- WB** WHEELBASE
RADSTAND
- ST** STACK
STACK
- RE** REACH
REACH
- SOH** STANDOVER HEIGHT
ÜBERSTANDSHÖHE
-  HEAD SET DIAMETER (UPPER / LOWER)
STEUERSATZDURCHMESSER (OBEN / UNTEN)
-  AXLE STANDARD (REAR / FRONT)
ACHSENSTANDARD (HINTEN / VORNE)
-  BOTTOM BRACKET STANDARD
TRETLAGERSTANDARD
-  SEAT POST DIAMETER
SITTELSTÜTZENDURCHMESSER
-  SHOCK HARDWARE (Ø 8 MM)
DÄMPFERBUCHSENMASSE (Ø 8 MM)
-  SHOCK LENGTH
DÄMPFERBAUÄNGE
-  SHOCK TRAVEL
DÄMPFERHUB
-  FRONT FORK TRAVEL
FEDERWEG VORNE
-  REAR WHEEL TRAVEL
FEDERWEG HINTEN
-  STEM LENGTH
VORBAUÄNGE
-  HANDLEBAR WIDTH
LENKERBREITE
-  CRANK LENGTH
KURBELLENGE
-  SEAT TUBE BOTTLE MOUNT
FLASCHE SITZELROHR
-  DOWNTUBE BOTTLE MOUNT
FLASCHE UNTERROHR













| | STL | CSL | TTL | HTL | HTA | STA | BB | WB | ST | RE | SOH |  |  |  |  |  |  |  |  |  |  |  |  |  |  | | |
|---------------------------|-----|-----|-----|-----|-----|------|----|------|-----|-----|-----|---|---|---|---|---|---|--|---|---|---|---|---|---|---|--|--|
| KATO PRO 29" | | | | | | | | | | | | | | | | | | | | | | | | | | | |
| S | 400 | 450 | 575 | 105 | 68 | 73.5 | 60 | 1112 | 613 | 392 | 715 | 44 / 44 | 135/100 | BSA 73 | 30,9 | - / - | 0 | 0 | 100 | 0 | 50 | 720 | 170 | - | 0,75 | | |
| M | 440 | 450 | 595 | 115 | 68 | 73.5 | 60 | 1133 | 622 | 409 | 735 | 44 / 44 | 135/100 | BSA 73 | 30,9 | - / - | 0 | 0 | 100 | 0 | 50 | 740 | 170 | 0,5 | 0,75 | | |
| L | 480 | 450 | 615 | 125 | 68 | 73.5 | 60 | 1154 | 632 | 426 | 765 | 44 / 44 | 135/100 | BSA 73 | 30,9 | - / - | 0 | 0 | 100 | 0 | 50 | 740 | 175 | 0,75 | 0,75 | | |
| XL | 520 | 450 | 635 | 135 | 68 | 73.5 | 60 | 1175 | 641 | 443 | 780 | 44 / 44 | 135/100 | BSA 73 | 30,9 | - / - | 0 | 0 | 100 | 0 | 50 | 760 | 175 | 0,75 | 0,75 | | |
| KATO ADVANCED 29" | | | | | | | | | | | | | | | | | | | | | | | | | | | |
| S | 400 | 450 | 575 | 105 | 68 | 73.5 | 60 | 1112 | 613 | 392 | 715 | 44 / 44 | 135/100 | BSA 73 | 30,9 | - / - | 0 | 0 | 100 | 0 | 50 | 720 | 170 | - | 0,75 | | |
| M | 440 | 450 | 595 | 115 | 68 | 73.5 | 60 | 1133 | 622 | 409 | 735 | 44 / 44 | 135/100 | BSA 73 | 30,9 | - / - | 0 | 0 | 100 | 0 | 50 | 740 | 170 | 0,5 | 0,75 | | |
| L | 480 | 450 | 615 | 125 | 68 | 73.5 | 60 | 1154 | 632 | 426 | 765 | 44 / 44 | 135/100 | BSA 73 | 30,9 | - / - | 0 | 0 | 100 | 0 | 50 | 740 | 175 | 0,75 | 0,75 | | |
| XL | 520 | 450 | 635 | 135 | 68 | 73.5 | 60 | 1175 | 641 | 443 | 780 | 44 / 44 | 135/100 | BSA 73 | 30,9 | - / - | 0 | 0 | 100 | 0 | 50 | 760 | 175 | 0,75 | 0,75 | | |
| KATO UNIVERSAL 29" | | | | | | | | | | | | | | | | | | | | | | | | | | | |
| S | 400 | 450 | 575 | 105 | 68 | 73.5 | 60 | 1112 | 613 | 392 | 715 | 44 / 44 | 135/100 | BSA 73 | 30,9 | - / - | 0 | 0 | 100 | 0 | 50 | 720 | 170 | - | 0,75 | | |
| M | 440 | 450 | 595 | 115 | 68 | 73.5 | 60 | 1133 | 622 | 409 | 735 | 44 / 44 | 135/100 | BSA 73 | 30,9 | - / - | 0 | 0 | 100 | 0 | 50 | 740 | 170 | 0,5 | 0,75 | | |
| L | 480 | 450 | 615 | 125 | 68 | 73.5 | 60 | 1154 | 632 | 426 | 765 | 44 / 44 | 135/100 | BSA 73 | 30,9 | - / - | 0 | 0 | 100 | 0 | 50 | 740 | 175 | 0,75 | 0,75 | | |
| XL | 520 | 450 | 635 | 135 | 68 | 73.5 | 60 | 1175 | 641 | 443 | 780 | 44 / 44 | 135/100 | BSA 73 | 30,9 | - / - | 0 | 0 | 100 | 0 | 50 | 760 | 175 | 0,75 | 0,75 | | |
| KATO ESSENTIAL 29" | | | | | | | | | | | | | | | | | | | | | | | | | | | |
| S | 400 | 450 | 575 | 105 | 68 | 73.5 | 60 | 1112 | 613 | 392 | 715 | 44 / 44 | 135/100 | BSA 73 | 30,9 | - / - | 0 | 0 | 100 | 0 | 50 | 720 | 170 | - | 0,75 | | |
| M | 440 | 450 | 595 | 115 | 68 | 73.5 | 60 | 1133 | 622 | 409 | 735 | 44 / 44 | 135/100 | BSA 73 | 30,9 | - / - | 0 | 0 | 100 | 0 | 50 | 740 | 170 | 0,5 | 0,75 | | |
| L | 480 | 450 | 615 | 125 | 68 | 73.5 | 60 | 1154 | 632 | 426 | 765 | 44 / 44 | 135/100 | BSA 73 | 30,9 | - / - | 0 | 0 | 100 | 0 | 50 | 740 | 175 | 0,75 | 0,75 | | |
| XL | 520 | 450 | 635 | 135 | 68 | 73.5 | 60 | 1175 | 641 | 443 | 780 | 44 / 44 | 135/100 | BSA 73 | 30,9 | - / - | 0 | 0 | 100 | 0 | 50 | 760 | 175 | 0,75 | 0,75 | | |
| KATO 29" | | | | | | | | | | | | | | | | | | | | | | | | | | | |
| S | 400 | 450 | 575 | 105 | 68 | 73.5 | 60 | 1112 | 613 | 392 | 715 | 44 / 44 | 135/100 | BSA 73 | 30,9 | - / - | 0 | 0 | 100 | 0 | 50 | 720 | 170 | - | 0,75 | | |
| M | 440 | 450 | 595 | 115 | 68 | 73.5 | 60 | 1133 | 622 | 409 | 735 | 44 / 44 | 135/100 | BSA 73 | 30,9 | - / - | 0 | 0 | 100 | 0 | 50 | 740 | 170 | 0,5 | 0,75 | | |
| L | 480 | 450 | 615 | 125 | 68 | 73.5 | 60 | 1154 | 632 | 426 | 765 | 44 / 44 | 135/100 | BSA 73 | 30,9 | - / - | 0 | 0 | 100 | 0 | 50 | 740 | 175 | 0,75 | 0,75 | | |
| XL | 520 | 450 | 635 | 135 | 68 | 73.5 | 60 | 1175 | 641 | 443 | 780 | 44 / 44 | 135/100 | BSA 73 | 30,9 | - / - | 0 | 0 | 100 | 0 | 50 | 760 | 175 | 0,75 | 0,75 | | |
| KATO EQ 29" | | | | | | | | | | | | | | | | | | | | | | | | | | | |
| S | 400 | 450 | 575 | 105 | 68 | 73.5 | 60 | 1112 | 613 | 392 | 715 | 44 / 44 | 135/100 | BSA 73 | 30,9 | - / - | 0 | 0 | 100 | 0 | 50 | 720 | 170 | - | 0,75 | | |
| M | 440 | 450 | 595 | 115 | 68 | 73.5 | 60 | 1133 | 622 | 409 | 735 | 44 / 44 | 135/100 | BSA 73 | 30,9 | - / - | 0 | 0 | 100 | 0 | 50 | 740 | 170 | 0,5 | 0,75 | | |
| L | 480 | 450 | 615 | 125 | 68 | 73.5 | 60 | 1154 | 632 | 426 | 765 | 44 / 44 | 135/100 | BSA 73 | 30,9 | - / - | 0 | 0 | 100 | 0 | 50 | 740 | 175 | 0,75 | 0,75 | | |
| XL | 520 | 450 | 635 | 135 | 68 | 73.5 | 60 | 1175 | 641 | 443 | 780 | 44 / 44 | 135/100 | BSA 73 | 30,9 | - / - | 0 | 0 | 100 | 0 | 50 | 760 | 175 | 0,75 | 0,75 | | |













KATO



























- STL** SEAT TUBE LENGTH
SITZROHRLÄNGE
- CSL** CHAINSTAY LENGTH
KETTENSTREBENLÄNGE
- TTL** TOP TUBE LENGTH
OBERROHRLÄNGE
- HTL** HEAD TUBE LENGTH
STEUERROHRLÄNGE
- HTA** HEAD TUBE ANGLE
STEUERROHRWINKEL
- STA** SEAT TUBE ANGLE
SITZROHRWINKEL
- BB** BOTTOM BRACKET DROP
INNENLAGERABSENKUNG
- WB** WHEELBASE
RADSTAND
- ST** STACK
VORBAULÄNGE
- RE** REACH
REACH
- SOH** STANDOVER HEIGHT
ÜBERSTANDSHÖHE
-  HEAD SET DIAMETER (UPPER / LOWER)
STEUERSATZDURCHMESSER (OBEN / UNTEN)
-  AXLE STANDARD (REAR / FRONT)
ACHSENSTANDARD (HINTEN / VORNE)
-  BOTTOM BRACKET STANDARD
TRETLAGERSTANDARD
-  SEAT POST DIAMETER
SÄTTELSTÜTZENDURCHMESSER
-  SHOCK HARDWARE (Ø 8 MM)
DÄMPFERBUCHSENMASSE (Ø 8 MM)
-  SHOCK LENGTH
DÄMPFEREINBAULÄNGE
-  SHOCK TRAVEL
DÄMPFERHUB
-  FRONT FORK TRAVEL
FEDERWEG VORNE
-  REAR WHEEL TRAVEL
FEDERWEG HINTEN
-  STEM LENGTH
VORBAULÄNGE
-  HANDLEBAR WIDTH
LENKERBREITE
-  CRANK LENGTH
KURBELLÄNGE
-  SEAT TUBE BOTTLE MOUNT
FLASCHE SÄTTELROHR
-  DOWNTUBE BOTTLE MOUNT
FLASCHE UNTERROHR













| | STL | CSL | TTL | HTL | HTA | STA | BB | WB | ST | RE | SOH |  |  |  |  |  |  |  |  |  |  |  |  | DT | |
|-----------------------|-----|-----|-----|-----|-----|------|----|------|-----|-----|-----|---|---|---|---|---|---|---|---|---|---|---|---|-----|------|
| KATO PRO 27.5" | | | | | | | | | | | | | | | | | | | | | | | | | |
| XS | 360 | 430 | 545 | 105 | 68 | 73.5 | 45 | 1063 | 588 | 371 | 680 | 44 / 44 | 135/100 | BSA 73 | 31.6 | - / - | 0 | 0 | 100 | 0 | 50 | 700 | 170 | - | 0.5 |
| S | 400 | 430 | 570 | 115 | 68 | 73.5 | 45 | 1089 | 598 | 393 | 710 | 44 / 44 | 135/100 | BSA 73 | 31.6 | - / - | 0 | 0 | 100 | 0 | 50 | 720 | 170 | - | 0.75 |
| M | 440 | 430 | 590 | 125 | 68 | 73.5 | 45 | 1110 | 607 | 411 | 730 | 44 / 44 | 135/100 | BSA 73 | 31.6 | - / - | 0 | 0 | 100 | 0 | 50 | 740 | 170 | 0.5 | 0.75 |

| | STL | CSL | TTL | HTL | HTA | STA | BB | WB | ST | RE | SOH |  |  |  |  |  |  |  |  |  |  |  |  | DT | |
|----------------------------|-----|-----|-----|-----|-----|------|----|------|-----|-----|-----|---|---|---|---|---|---|---|---|---|---|---|---|-----|------|
| KATO ADVANCED 27.5" | | | | | | | | | | | | | | | | | | | | | | | | | |
| XS | 360 | 430 | 545 | 105 | 68 | 73.5 | 45 | 1063 | 588 | 371 | 680 | 44 / 44 | 135/100 | BSA 73 | 31.6 | - / - | 0 | 0 | 100 | 0 | 50 | 700 | 170 | - | 0.5 |
| S | 400 | 430 | 570 | 115 | 68 | 73.5 | 45 | 1089 | 598 | 393 | 710 | 44 / 44 | 135/100 | BSA 73 | 31.6 | - / - | 0 | 0 | 100 | 0 | 50 | 720 | 170 | - | 0.75 |
| M | 440 | 430 | 590 | 125 | 68 | 73.5 | 45 | 1110 | 607 | 411 | 730 | 44 / 44 | 135/100 | BSA 73 | 31.6 | - / - | 0 | 0 | 100 | 0 | 50 | 740 | 170 | 0.5 | 0.75 |

| | STL | CSL | TTL | HTL | HTA | STA | BB | WB | ST | RE | SOH |  |  |  |  |  |  |  |  |  |  |  |  | DT | |
|-----------------------------|-----|-----|-----|-----|-----|------|----|------|-----|-----|-----|---|---|---|---|---|---|---|---|---|---|---|---|-----|------|
| KATO UNIVERSAL 27.5" | | | | | | | | | | | | | | | | | | | | | | | | | |
| XS | 360 | 430 | 545 | 105 | 68 | 73.5 | 45 | 1063 | 588 | 371 | 680 | 44 / 44 | 135/100 | BSA 73 | 31.6 | - / - | 0 | 0 | 100 | 0 | 50 | 700 | 170 | - | 0.5 |
| S | 400 | 430 | 570 | 115 | 68 | 73.5 | 45 | 1089 | 598 | 393 | 710 | 44 / 44 | 135/100 | BSA 73 | 31.6 | - / - | 0 | 0 | 100 | 0 | 50 | 720 | 170 | - | 0.75 |
| M | 440 | 430 | 590 | 125 | 68 | 73.5 | 45 | 1110 | 607 | 411 | 730 | 44 / 44 | 135/100 | BSA 73 | 31.6 | - / - | 0 | 0 | 100 | 0 | 50 | 740 | 170 | 0.5 | 0.75 |

| | STL | CSL | TTL | HTL | HTA | STA | BB | WB | ST | RE | SOH |  |  |  |  |  |  |  |  |  |  |  |  | DT | |
|-----------------------------|-----|-----|-----|-----|-----|------|----|------|-----|-----|-----|---|---|---|---|---|---|---|---|---|---|---|---|-----|------|
| KATO ESSENTIAL 27.5" | | | | | | | | | | | | | | | | | | | | | | | | | |
| XS | 360 | 430 | 545 | 105 | 68 | 73.5 | 45 | 1063 | 588 | 371 | 680 | 44 / 44 | 135/100 | BSA 73 | 31.6 | - / - | 0 | 0 | 100 | 0 | 50 | 700 | 170 | - | 0.5 |
| S | 400 | 430 | 570 | 115 | 68 | 73.5 | 45 | 1089 | 598 | 393 | 710 | 44 / 44 | 135/100 | BSA 73 | 31.6 | - / - | 0 | 0 | 100 | 0 | 50 | 720 | 170 | - | 0.75 |
| M | 440 | 430 | 590 | 125 | 68 | 73.5 | 45 | 1110 | 607 | 411 | 730 | 44 / 44 | 135/100 | BSA 73 | 31.6 | - / - | 0 | 0 | 100 | 0 | 50 | 740 | 170 | 0.5 | 0.75 |

| | STL | CSL | TTL | HTL | HTA | STA | BB | WB | ST | RE | SOH |  |  |  |  |  |  |  |  |  |  |  |  | DT | |
|-------------------|-----|-----|-----|-----|-----|------|----|------|-----|-----|-----|---|---|---|---|---|---|---|---|---|---|---|---|-----|------|
| KATO 27.5" | | | | | | | | | | | | | | | | | | | | | | | | | |
| XS | 360 | 430 | 545 | 105 | 68 | 73.5 | 45 | 1063 | 588 | 371 | 680 | 44 / 44 | 135/100 | BSA 73 | 31.6 | - / - | 0 | 0 | 100 | 0 | 50 | 700 | 175 | - | 0.5 |
| S | 400 | 430 | 570 | 115 | 68 | 73.5 | 45 | 1089 | 598 | 393 | 710 | 44 / 44 | 135/100 | BSA 73 | 31.6 | - / - | 0 | 0 | 100 | 0 | 50 | 720 | 170 | - | 0.75 |
| M | 440 | 430 | 590 | 125 | 68 | 73.5 | 45 | 1110 | 607 | 411 | 730 | 44 / 44 | 135/100 | BSA 73 | 31.6 | - / - | 0 | 0 | 100 | 0 | 50 | 740 | 170 | 0.5 | 0.75 |

| | STL | CSL | TTL | HTL | HTA | STA | BB | WB | ST | RE | SOH |  |  |  |  |  |  |  |  |  |  |  |  | DT | |
|----------------------|-----|-----|-----|-----|-----|------|----|------|-----|-----|-----|---|---|---|---|---|---|---|---|---|---|---|---|-----|------|
| KATO EQ 27.5" | | | | | | | | | | | | | | | | | | | | | | | | | |
| XS | 360 | 430 | 545 | 105 | 68 | 73.5 | 45 | 1063 | 588 | 371 | 680 | 44 / 44 | 135/100 | BSA 73 | 31.6 | - / - | 0 | 0 | 100 | 0 | 50 | 700 | 170 | - | 0.5 |
| S | 400 | 430 | 570 | 115 | 68 | 73.5 | 45 | 1089 | 598 | 393 | 710 | 44 / 44 | 135/100 | BSA 73 | 31.6 | - / - | 0 | 0 | 100 | 0 | 50 | 720 | 170 | - | 0.75 |
| M | 440 | 430 | 590 | 125 | 68 | 73.5 | 45 | 1110 | 607 | 411 | 730 | 44 / 44 | 135/100 | BSA 73 | 31.6 | - / - | 0 | 0 | 100 | 0 | 50 | 740 | 170 | 0.5 | 0.75 |

LANAO

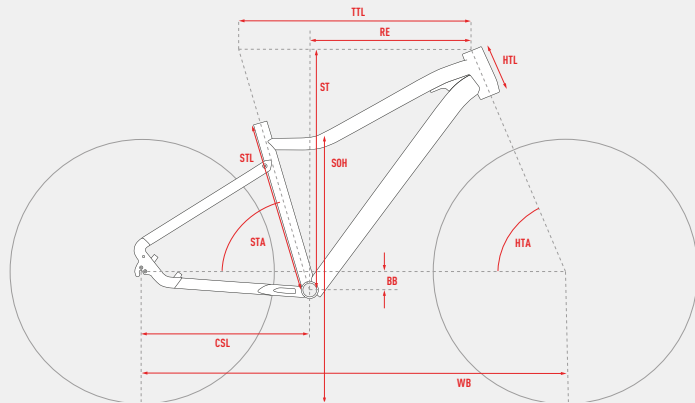

ALL DIMENSIONS IN MM (EXCEPT HTA AND STA IN °)

ALLE MASSE IN MM (AUSNAHME HTA UND STA IN °)

- STL** SEAT TUBE LENGTH
SITZROHRLÄNGE
- CSL** CHAINSTAY LENGTH
KETTENSTREBENLÄNGE
- TTL** TOP TUBE LENGTH
OBERROHRLÄNGE
- HTL** HEAD TUBE LENGTH
STEUERROHRLÄNGE
- HTA** HEAD TUBE ANGLE
STEUERROHRWINKEL
- STA** SEAT TUBE ANGLE
SITZROHRWINKEL
- BB** BOTTOM BRACKET DROP
INNENLAGERABSENKUNG
- WB** WHEELBASE
RADSTAND
- ST** STACK
STACK
- RE** REACH
REACH
- SOH** STANDOVER HEIGHT
ÜBERSTANDSHÖHE
- HEAD SET DIAMETER (UPPER / LOWER)
STEUERSATZDURCHMESSER (OBEN / UNTEN)
- AXLE STANDARD (REAR / FRONT)
ACHSENSTANDARD (HINTEN / VORNE)
- BOTTOM BRACKET STANDARD
TRETLAGERSTANDARD
- SEAT POST DIAMETER
SITTELSTÜTZENDURCHMESSER
- SHOCK HARDWARE (Ø 8 MM)
DÄMPFERBUCHSENMASSE (Ø 8 MM)
- SHOCK LENGTH
DÄMPFEREINBAULÄNGE
- SHOCK TRAVEL
DÄMPFERHUB
- FRONT FORK TRAVEL
FEDERWEG VORNE
- REAR WHEEL TRAVEL
FEDERWEG HINTEN
- STEM LENGTH
VORBAULÄNGE
- HANDLEBAR WIDTH
LENKERBREITE
- CRANK LENGTH
KURBELLÄNGE
- SEAT TUBE BOTTLE MOUNT
FLASCHE SITTELROHR
- DOWNTUBE BOTTLE MOUNT
FLASCHE UNTERROHR

| | STL | CSL | TTL | HTL | HTA | STA | BB | WB | ST | RE | SOH | | | | | | | | | | | | | DT | |
|------------------------|-----|-----|-----|-----|-----|------|----|------|-----|-----|-----|---------|---------|--------|------|-------|---|---|-----|---|----|-----|-----|-----|------|
| LANAO PRO 27.5" | | | | | | | | | | | | | | | | | | | | | | | | | |
| XS | 360 | 430 | 545 | 105 | 68 | 73.5 | 45 | 1063 | 588 | 371 | 680 | 44 / 44 | 135/100 | BSA 73 | 31.6 | - / - | 0 | 0 | 100 | 0 | 50 | 700 | 170 | - | 0.5 |
| S | 400 | 430 | 570 | 115 | 68 | 73.5 | 45 | 1089 | 598 | 393 | 710 | 44 / 44 | 135/100 | BSA 73 | 31.6 | - / - | 0 | 0 | 100 | 0 | 50 | 720 | 170 | - | 0.75 |
| M | 440 | 430 | 590 | 125 | 68 | 73.5 | 45 | 1110 | 607 | 411 | 730 | 44 / 44 | 135/100 | BSA 73 | 31.6 | - / - | 0 | 0 | 100 | 0 | 50 | 740 | 170 | 0.5 | 0.75 |

| | STL | CSL | TTL | HTL | HTA | STA | BB | WB | ST | RE | SOH | | | | | | | | | | | | | DT | |
|-----------------------------|-----|-----|-----|-----|-----|------|----|------|-----|-----|-----|---------|---------|--------|------|-------|---|---|-----|---|----|-----|-----|-----|------|
| LANAO ADVANCED 27.5" | | | | | | | | | | | | | | | | | | | | | | | | | |
| XS | 360 | 430 | 545 | 105 | 68 | 73.5 | 45 | 1063 | 588 | 371 | 680 | 44 / 44 | 135/100 | BSA 73 | 31.6 | - / - | 0 | 0 | 100 | 0 | 50 | 700 | 170 | - | 0.5 |
| S | 400 | 430 | 570 | 115 | 68 | 73.5 | 45 | 1089 | 598 | 393 | 710 | 44 / 44 | 135/100 | BSA 73 | 31.6 | - / - | 0 | 0 | 100 | 0 | 50 | 720 | 170 | - | 0.75 |
| M | 440 | 430 | 590 | 125 | 68 | 73.5 | 45 | 1110 | 607 | 411 | 730 | 44 / 44 | 135/100 | BSA 73 | 31.6 | - / - | 0 | 0 | 100 | 0 | 50 | 740 | 170 | 0.5 | 0.75 |

| | STL | CSL | TTL | HTL | HTA | STA | BB | WB | ST | RE | SOH | | | | | | | | | | | | | DT | |
|------------------------|-----|-----|-----|-----|-----|------|----|------|-----|-----|-----|---------|---------|--------|------|-------|---|---|-----|---|----|-----|-----|-----|------|
| LANAO UNIVERSAL | | | | | | | | | | | | | | | | | | | | | | | | | |
| XS | 360 | 430 | 545 | 105 | 68 | 73.5 | 45 | 1063 | 588 | 371 | 680 | 44 / 44 | 135/100 | BSA 73 | 31.6 | - / - | 0 | 0 | 100 | 0 | 50 | 700 | 170 | - | 0.5 |
| S | 400 | 430 | 570 | 115 | 68 | 73.5 | 45 | 1089 | 598 | 393 | 710 | 44 / 44 | 135/100 | BSA 73 | 31.6 | - / - | 0 | 0 | 100 | 0 | 50 | 720 | 170 | - | 0.75 |
| M | 440 | 430 | 590 | 125 | 68 | 73.5 | 45 | 1110 | 607 | 411 | 730 | 44 / 44 | 135/100 | BSA 73 | 31.6 | - / - | 0 | 0 | 100 | 0 | 50 | 740 | 170 | 0.5 | 0.75 |

| | STL | CSL | TTL | HTL | HTA | STA | BB | WB | ST | RE | SOH | | | | | | | | | | | | | DT | |
|------------------------------|-----|-----|-----|-----|-----|------|----|------|-----|-----|-----|---------|---------|--------|------|-------|---|---|-----|---|----|-----|-----|-----|------|
| LANAO ESSENTIAL 27.5" | | | | | | | | | | | | | | | | | | | | | | | | | |
| XS | 360 | 430 | 545 | 105 | 68 | 73.5 | 45 | 1063 | 588 | 371 | 680 | 44 / 44 | 135/100 | BSA 73 | 31.6 | - / - | 0 | 0 | 100 | 0 | 50 | 700 | 170 | - | 0.5 |
| S | 400 | 430 | 570 | 115 | 68 | 73.5 | 45 | 1089 | 598 | 393 | 710 | 44 / 44 | 135/100 | BSA 73 | 31.6 | - / - | 0 | 0 | 100 | 0 | 50 | 720 | 170 | - | 0.75 |
| M | 440 | 430 | 590 | 125 | 68 | 73.5 | 45 | 1110 | 607 | 411 | 730 | 44 / 44 | 135/100 | BSA 73 | 31.6 | - / - | 0 | 0 | 100 | 0 | 50 | 740 | 170 | 0.5 | 0.75 |

| | STL | CSL | TTL | HTL | HTA | STA | BB | WB | ST | RE | SOH | | | | | | | | | | | | | DT | |
|--------------------|-----|-----|-----|-----|-----|------|----|------|-----|-----|-----|---------|---------|--------|------|-------|---|---|-----|---|----|-----|-----|-----|------|
| LANAO 27.5" | | | | | | | | | | | | | | | | | | | | | | | | | |
| XS | 360 | 430 | 545 | 105 | 68 | 73.5 | 45 | 1063 | 588 | 371 | 680 | 44 / 44 | 135/100 | BSA 73 | 31.6 | - / - | 0 | 0 | 100 | 0 | 50 | 700 | 170 | - | 0.5 |
| S | 400 | 430 | 570 | 115 | 68 | 73.5 | 45 | 1089 | 598 | 393 | 710 | 44 / 44 | 135/100 | BSA 73 | 31.6 | - / - | 0 | 0 | 100 | 0 | 50 | 720 | 170 | - | 0.75 |
| M | 440 | 430 | 590 | 125 | 68 | 73.5 | 45 | 1110 | 607 | 411 | 730 | 44 / 44 | 135/100 | BSA 73 | 31.6 | - / - | 0 | 0 | 100 | 0 | 50 | 740 | 170 | 0.5 | 0.75 |

| | STL | CSL | TTL | HTL | HTA | STA | BB | WB | ST | RE | SOH | | | | | | | | | | | | | DT | |
|-----------------------|-----|-----|-----|-----|-----|------|----|------|-----|-----|-----|---------|---------|--------|------|-------|---|---|-----|---|----|-----|-----|-----|------|
| LANAO EQ 27.5" | | | | | | | | | | | | | | | | | | | | | | | | | |
| XS | 360 | 430 | 545 | 105 | 68 | 73.5 | 45 | 1063 | 588 | 371 | 680 | 44 / 44 | 135/100 | BSA 73 | 31.6 | - / - | 0 | 0 | 100 | 0 | 50 | 700 | 170 | - | 0.5 |
| S | 400 | 430 | 570 | 115 | 68 | 73.5 | 45 | 1089 | 598 | 393 | 710 | 44 / 44 | 135/100 | BSA 73 | 31.6 | - / - | 0 | 0 | 100 | 0 | 50 | 720 | 170 | - | 0.75 |
| M | 440 | 430 | 590 | 125 | 68 | 73.5 | 45 | 1110 | 607 | 411 | 730 | 44 / 44 | 135/100 | BSA 73 | 31.6 | - / - | 0 | 0 | 100 | 0 | 50 | 740 | 170 | 0.5 | 0.75 |

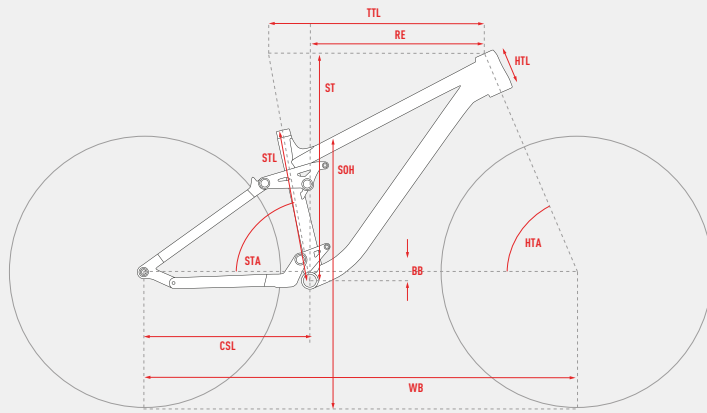

ALL DIMENSIONS IN MM (EXCEPT HTA AND STA IN °)

ALLE MASSE IN MM (AUSNAHME HTA UND STA IN °)

- STL** SEAT TUBE LENGTH
SITZROHRLÄNGE
- CSL** CHAINSTAY LENGTH
KETTENSTREBENLÄNGE
- TTL** TOP TUBE LENGTH
OBERROHRLÄNGE
- HTL** HEADTUBE LENGTH
STEUERROHRLÄNGE
- HTA** HEADTUBE ANGLE
STEUERROHRWINKEL
- RE** REACH
- SOH** STANDOVER HEIGHT
ÜBERSTANDSHÖHE
- HEAD SET DIAMETER (UPPER / LOWER)**
STEUERSATZDURCHMESSER (OBEN / UNTEN)
- AXLE STANDARD (REAR / FRONT)**
ACHSENSTANDARD (HINTEN / VORNE)
- BOTTOM BRACKET STANDARD**
TRETLÄGERSTANDARD
- SEAT POST DIAMETER**
SITZELSTÜTZENDURCHMESSER
- SHOCK HARDWARE (Ø 8 MM)**
DAMPFERBUCHSENMASSE (Ø 8 MM)
- SHOCK LENGTH**
DAMPFEREINBAULÄNGE
- SHOCK TRAVEL**
DAMPFERHUB
- FRONT FORK TRAVEL**
FEDERWEG VORNE
- REAR WHEEL TRAVEL**
FEDERWEG HINTEN
- STEM LENGTH**
VORBAULÄNGE
- HANDLEBAR WIDTH**
LENKERBREITE
- CRANK LENGTH**
KURBELLÄNGE
- SEAT TUBE BOTTLE MOUNT**
FLASCHE SITZELROHR
- DOWN TUBE BOTTLE MOUNT**
FLASCHE UNTERROHR

| | STL | CSL | TTL | HTL | HTA | STA | BB | WB | ST | RE | SOH | | | | | | | | | | | | | | | ST | DT |
|-----------------------|-----|-----|-----|-----|-----|-----|----|------|-----|-----|-----|---------|---------|--------|------|---------|-----|----|-----|-----|----|-----|-----|---|-----|----|----|
| RIOT YOUTH PRO | | | | | | | | | | | | | | | | | | | | | | | | | | | |
| XS | 385 | 430 | 550 | 100 | 66 | 77 | 22 | 1145 | 578 | 419 | 698 | 44 / 56 | 148/110 | BSA 73 | 31,6 | 30 / 30 | 210 | 50 | 130 | 130 | 50 | 700 | 170 | - | 0,5 | | |



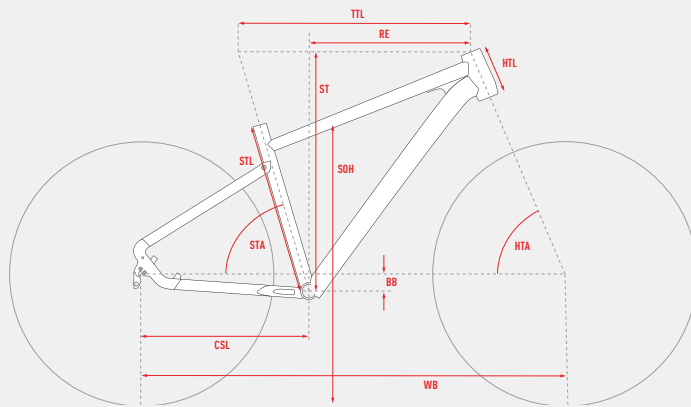









KATO YOUTH



ALL DIMENSIONS IN MM (EXCEPT HTA AND STA IN °)

ALLE MASSE IN MM (AUSNAHME HTA UND STA IN °)

- STL** SEAT TUBE LENGTH
SITZROHRLÄNGE
- CSL** CHAINSTAY LENGTH
KETTENSTREBENLÄNGE
- TTL** TOP TUBE LENGTH
OBERROHRLÄNGE
- HTL** HEAD TUBE LENGTH
STEUERROHRLÄNGE
- HTA** HEAD TUBE ANGLE
STEUERROHRWINKEL
- STA** SEAT TUBE ANGLE
SITZROHRWINKEL
- BB** BOTTOM BRACKET DROP
INNENLAGERABSENKUNG
- WB** WHEELBASE
RADSTAND
- ST** STACK
STACK
- RE** REACH
REACH
- SOH** STANDOVER HEIGHT
ÜBERSTANDSHÖHE
-  **HEAD SET DIAMETER (UPPER / LOWER)**
STEUERSATZDURCHMESSER (OBEN / UNTEN)
-  **AXLE STANDARD (REAR / FRONT)**
ACHSENSTANDARD (HINTEN / VORNE)
-  **BOTTOM BRACKET STANDARD**
TRETLAGERSTANDARD
-  **SEAT POST DIAMETER**
SITTELSTÜTZENDURCHMESSER
-  **SHOCK HARDWARE (Ø 8 MM)**
DÄMPFERBUCHSENMASSE (Ø 8 MM)
-  **SHOCK LENGTH**
DÄMPFEREINBAULÄNGE
-  **SHOCK TRAVEL**
DÄMPFERHUB
-  **FRONT FORK TRAVEL**
FEDERWEG VORNE
-  **REAR WHEEL TRAVEL**
FEDERWEG HINTEN
-  **STEM LENGTH**
VORBAULÄNGE
-  **HANDLEBAR WIDTH**
LENKERBREITE
-  **CRANK LENGTH**
KURBELLÄNGE
-  **SEATTUBE BOTTLE MOUNT**
FLASCHE SITTELROHR
-  **DOWNTUBE BOTTLE MOUNT**
FLASCHE UNTERROHR

STL CSL TTL HTL HTA STA BB WB ST RE SOH             

KATO YOUTH

XXS 340 430 531 95 68 73.5 45 1048 579 360 670 0 / 0 135/100 BSA 73 31,6 - / - 0 0 100 0 50 700 170 - 0,5

KATO YOUTH EQ

XXS 340 430 531 95 68 73.5 45 1048 579 360 670 0 / 0 135/100 BSA 73 31,6 - / - 0 0 100 0 50 700 170 - 0,5

LANAO YOUTH

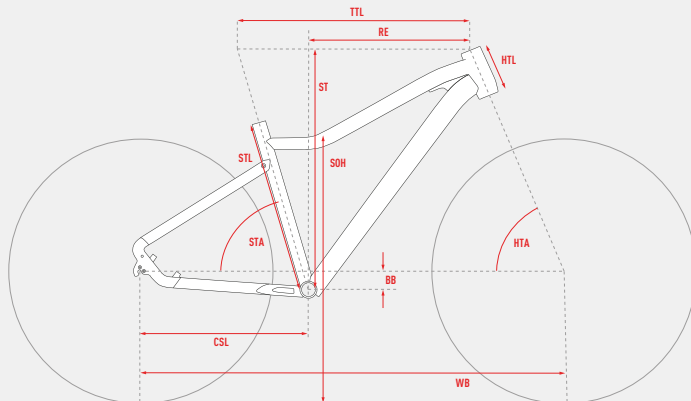

ALL DIMENSIONS IN MM (EXCEPT HTA AND STA IN °)

ALLE MASSE IN MM (AUSNAHME HTA UND STA IN °)

- STL** SEAT TUBE LENGTH
SITZROHRLÄNGE
- CSL** CHAINSTAY LENGTH
KETTENSTREBENLÄNGE
- TTL** TOP TUBE LENGTH
OBERROHRLÄNGE
- HTL** HEAD TUBE LENGTH
STEUERROHRLÄNGE
- HTA** HEAD TUBE ANGLE
STEUERROHRWINKEL
- STA** SEAT TUBE ANGLE
SITZROHRWINKEL
- BB** BOTTOM BRACKET DROP
INNENLAGERABSENKUNG
- WB** WHEELBASE
RADSTAND
- ST** STACK
STACK
- RE** REACH
REACH
- SOH** STANDOVER HEIGHT
ÜBERSTANDSHÖHE
- HEAD SET DIAMETER (UPPER / LOWER)
STEUERSATZDURCHMESSER (OBEN / UNTEN)
- AXLE STANDARD (REAR / FRONT)
ACHSENSTANDARD (HINTEN / VORNE)
- BOTTOM BRACKET STANDARD
TRETLAGERSTANDARD
- SEAT POST DIAMETER
SÄTTELSTÜTZENDURCHMESSER
- SHOCK HARDWARE (Ø 8 MM)
DÄMPFERBUCHSENMASSE (Ø 8 MM)
- SHOCK LENGTH
DÄMPFEREINBAULÄNGE
- SHOCK TRAVEL
DÄMPFERHUB
- FRONT FORK TRAVEL
FEDERWEG VORNE
- REAR WHEEL TRAVEL
FEDERWEG HINTEN
- STEM LENGTH
VORBAULÄNGE
- HANDLEBAR WIDTH
LENKERBREITE
- CRANK LENGTH
KURBELLÄNGE
- SEAT TUBE BOTTLE MOUNT
FLASCHE SÄTTELROHR
- DOWNTUBE BOTTLE MOUNT
FLASCHE UNTERROHR

STL CSL TTL HTL HTA STA BB WB ST RE SOH ST DT

LANAO YOUTH

XXS 340 430 531 95 68 73.5 45 1048 579 360 670 0 / 0 135/100 BSA 73 31,6 - / - 0 0 100 0 50 700 170 - 0,5

STL CSL TTL HTL HTA STA BB WB ST RE SOH ST DT

LANAO YOUTH EQ

XXS 340 430 531 95 68 73.5 45 1048 579 360 670 0 / 0 135/100 BSA 73 31,6 - / - 0 0 100 0 50 700 170 - 0,5

KATO KID

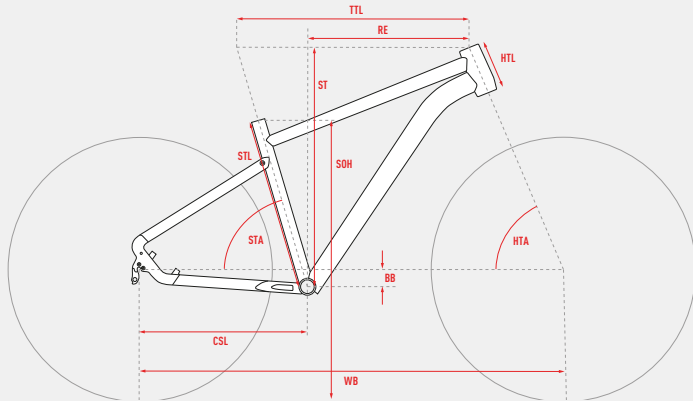

ALL DIMENSIONS IN MM (EXCEPT HTA AND STA IN °)

ALLE MASSE IN MM (AUSNAHME HTA UND STA IN °)

- STL** SEAT TUBE LENGTH
SITZROHRLÄNGE
- CSL** CHAINSTAY LENGTH
KETTENSTREBENLÄNGE
- TTL** TOP TUBE LENGTH
OBERROHRLÄNGE
- HTL** HEAD TUBE LENGTH
STEUERROHRLÄNGE
- HTA** HEAD TUBE ANGLE
STEUERROHRWINKEL
- STA** SEAT TUBE ANGLE
SITZROHRWINKEL
- BB** BOTTOM BRACKET DROP
INNENLAGERABSENKUNG
- WB** WHEELBASE
RADSTAND
- ST** STACK
STACK
- RE** REACH
REACH
- SOH** STANDOVER HEIGHT
ÜBERSTANDSHÖHE
- HEAD SET DIAMETER (UPPER / LOWER)
STEUERSATZDURCHMESSER (OBEN / UNTEN)

- AXLE STANDARD (REAR / FRONT)
ACHSENSTANDARD (HINTEN / VORNE)
- BOTTOM BRACKET STANDARD
TRETLAGERSTANDARD
- SEAT POST DIAMETER
SATTELSTÜTZENDURCHMESSER
- SHOCK HARDWARE (Ø 8 MM)
DAMPFERBUCHSENMASSE (Ø 8 MM)
- SHOCK LENGTH
DÄMPFEREINBAULÄNGE
- SHOCK TRAVEL
DÄMPFERHUB
- FRONT FORK TRAVEL
FEDERWEG VORNE
- REAR WHEEL TRAVEL
FEDERWEG HINTEN
- STEM LENGTH
VORBAULÄNGE
- HANDLEBAR WIDTH
LENKERBREITE
- CRANK LENGTH
KURBELLÄNGE
- SEAT TUBE BOTTLE MOUNT
FLASCHE SATTELROHR
- DOWNTUBE BOTTLE MOUNT
FLASCHE UNTERROHR

| | STL | CSL | TTL | HTL | HTA | STA | BB | WB | ST | RE | SOH | | | | | | | | | | | | | | |
|---------------------------|-----|-----|-----|-----|-----|-----|----|-----|-----|-----|-----|---------|---------|--------|------|-------|---|---|----|---|----|-----|-----|---|---|
| KATO 24 FULL PARTY | | | | | | | | | | | | | | | | | | | | | | | | | |
| 24 | 300 | 410 | 506 | 110 | 69 | 69 | 40 | 971 | 512 | 338 | 543 | 44 / 44 | 135/100 | BSA 73 | 27.2 | - / - | 0 | 0 | 80 | 0 | 40 | 560 | 140 | - | - |
| KATO 24 PRO | | | | | | | | | | | | | | | | | | | | | | | | | |
| 24 | 300 | 410 | 506 | 110 | 69 | 69 | 40 | 971 | 512 | 338 | 543 | 44 / 44 | 135/100 | BSA 73 | 27.2 | - / - | 0 | 0 | 50 | 0 | 40 | 560 | 140 | - | - |
| KATO 24 PRO EQ | | | | | | | | | | | | | | | | | | | | | | | | | |
| 24 | 300 | 410 | 506 | 110 | 69 | 69 | 40 | 971 | 512 | 338 | 543 | 44 / 44 | 135/100 | BSA 73 | 27.2 | - / - | 0 | 0 | 0 | 0 | 40 | 560 | 140 | - | - |
| KATO 20 FULL PARTY | | | | | | | | | | | | | | | | | | | | | | | | | |
| 20 | 250 | 362 | 437 | 110 | 68 | 69 | 45 | 843 | 455 | 280 | 473 | 44 / 44 | 135/100 | BSA 73 | 27.2 | - / - | 0 | 0 | 50 | 0 | 40 | 540 | 114 | - | - |
| KATO 20 PRO | | | | | | | | | | | | | | | | | | | | | | | | | |
| 20 | 250 | 362 | 437 | 110 | 68 | 69 | 45 | 843 | 455 | 280 | 473 | 44 / 44 | 135/100 | BSA 73 | 27.2 | - / - | 0 | 0 | 0 | 0 | 40 | 540 | 114 | - | - |

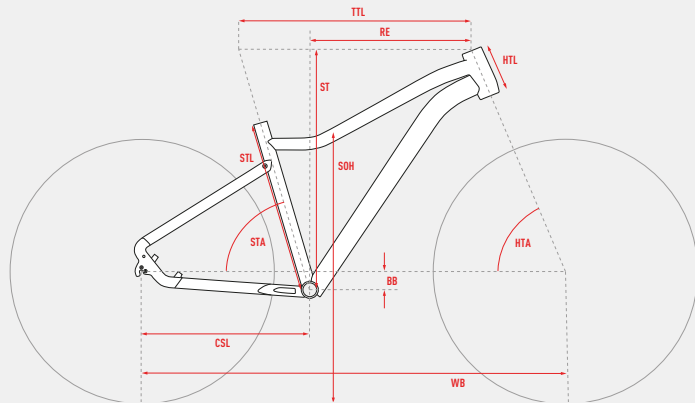

ALL DIMENSIONS IN MM (EXCEPT HTA AND STA IN °)

ALLE MASSE IN MM (AUSNAHME HTA UND STA IN °)

- STL** SEAT TUBE LENGTH
SITZROHRLÄNGE
- CSL** CHAINSTAY LENGTH
KETTENSTREBENLÄNGE
- TTL** TOP TUBE LENGTH
OBERROHRLÄNGE
- HTL** HEAD TUBE LENGTH
STEUERROHRLÄNGE
- HTA** HEAD TUBE ANGLE
STEUERROHRWINKEL
- STA** SEAT TUBE ANGLE
SITZROHRWINKEL
- BB** BOTTOM BRACKET DROP
INNENLAGERABSENKUNG
- WB** WHEELBASE
RADSTAND
- ST** STACK
STACK
- RE** REACH
REACH
- SOH** STANDOVER HEIGHT
ÜBERSTANDSHÖHE
- HEAD SET DIAMETER (UPPER / LOWER)
STEUERSATZDURCHMESSER (OBEN / UNTEN)
- AXLE STANDARD (REAR / FRONT)
ACHSENSTANDARD (HINTEN / VORNE)
- BOTTOM BRACKET STANDARD
TRETLAGERSTANDARD
- SEAT POST DIAMETER
SATTELSTÜTZENDURCHMESSER
- SHOCK HARDWARE (Ø 8 MM)
DÄMPFERBUCHSENMASSE (Ø 8 MM)
- SHOCK LENGTH
DÄMPFEREINBAULÄNGE
- SHOCK TRAVEL
DÄMPFERHUB
- FRONT FORK TRAVEL
FEDERWEG VORNE
- REAR WHEEL TRAVEL
FEDERWEG HINTEN
- STEM LENGTH
VORBAULÄNGE
- HANDLEBAR WIDTH
LENKERBREITE
- CRANK LENGTH
KURBELLÄNGE
- SEAT TUBE BOTTLE MOUNT
FLASCHE SATTELROHR
- DOWNTUBE BOTTLE MOUNT
FLASCHE UNTERROHR

| | STL | CSL | TTL | HTL | HTA | STA | BB | WB | ST | RE | SOH | | | | | | | | | | | | | | |
|----------------------------|-----|-----|-----|-----|-----|-----|----|-----|-----|-----|-----|---------|---------|--------|------|-------|---|---|----|---|----|-----|-----|---|---|
| LANAO 24 FULL PARTY | | | | | | | | | | | | | | | | | | | | | | | | | |
| 24 | 300 | 410 | 506 | 110 | 69 | 69 | 40 | 971 | 512 | 338 | 543 | 44 / 44 | 135/100 | BSA 73 | 27.2 | - / - | 0 | 0 | 80 | 0 | 40 | 560 | 140 | - | - |
| LANAO 24 PRO | | | | | | | | | | | | | | | | | | | | | | | | | |
| 24 | 300 | 410 | 506 | 110 | 69 | 69 | 40 | 971 | 512 | 338 | 543 | 44 / 44 | 135/100 | BSA 73 | 27.2 | - / - | 0 | 0 | 50 | 0 | 40 | 560 | 140 | - | - |
| LANAO 24 PRO EQ | | | | | | | | | | | | | | | | | | | | | | | | | |
| 24 | 300 | 410 | 506 | 110 | 69 | 69 | 40 | 971 | 512 | 338 | 543 | 44 / 44 | 135/100 | BSA 73 | 27.2 | - / - | 0 | 0 | 0 | 0 | 40 | 560 | 140 | - | - |
| LANAO 20 FULL PARTY | | | | | | | | | | | | | | | | | | | | | | | | | |
| 20 | 250 | 362 | 437 | 110 | 68 | 69 | 45 | 843 | 455 | 280 | 473 | 44 / 44 | 135/100 | BSA 73 | 27.2 | - / - | 0 | 0 | 50 | 0 | 40 | 540 | 114 | - | - |
| LANAO 20 PRO | | | | | | | | | | | | | | | | | | | | | | | | | |
| 20 | 250 | 362 | 437 | 110 | 68 | 69 | 45 | 843 | 455 | 280 | 473 | 44 / 44 | 135/100 | BSA 73 | 27.2 | - / - | 0 | 0 | 0 | 0 | 40 | 540 | 114 | - | - |

POWERKID

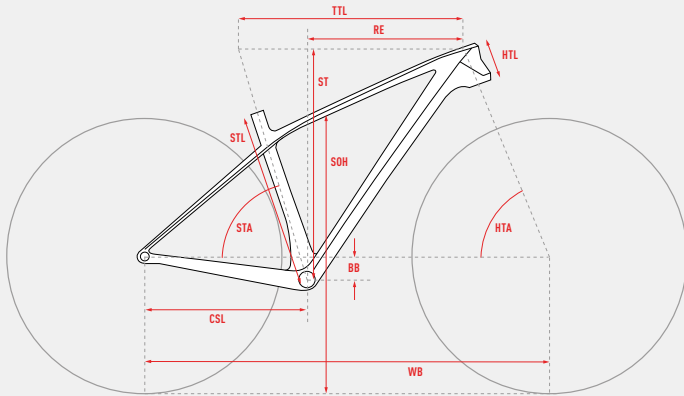















ALL DIMENSIONS IN MM (EXCEPT HTA AND STA IN °)

ALLE MASSE IN MM (AUSNAHME HTA UND STA IN °)

- STL** SEAT TUBE LENGTH
SITZROHRLÄNGE
- CSL** CHAINSTAY LENGTH
KETTENSTREBELÄNGE
- TTL** TOP TUBE LENGTH
OBERROHRLÄNGE
- HTL** HEAD TUBE LENGTH
STEUERROHRLÄNGE
- HTA** HEAD TUBE ANGLE
STEUERROHRWINKEL
- STA** SEAT TUBE ANGLE
SITZROHRWINKEL
- BB** BOTTOM BRACKET DROP
INNENLAGERABSENKUNG
- WB** WHEELBASE
RADSTAND
- ST** STACK
STACK
- RE** REACH
REACH
- SOH** STANDOVER HEIGHT
ÜBERSTANDSHÖHE
-  **HEAD SET DIAMETER (UPPER / LOWER)**
STEUERSATZDURCHMESSER (OBEN / UNTEN)

-  **AXLE STANDARD (REAR / FRONT)**
ACHSENSTANDARD (HINTEN / VORNE)
-  **BOTTOM BRACKET STANDARD**
TRETLAGERSTANDARD
-  **SEAT POST DIAMETER**
SITTELSTÜTZENDURCHMESSER
-  **SHOCK HARDWARE (Ø 8 MM)**
DÄMPFERBUCHSENMASSE (Ø 8 MM)
-  **SHOCK LENGTH**
DÄMPFEREINBAULÄNGE
-  **SHOCK TRAVEL**
DÄMPFERHUB
-  **FRONT FORK TRAVEL**
FEDERWEG VORNE
-  **REAR WHEEL TRAVEL**
FEDERWEG HINTEN
-  **STEM LENGTH**
VORBAULÄNGE
-  **HANDLEBAR WIDTH**
LENKERBREITE
-  **CRANK LENGTH**
KURBELLENGE
-  **SEAT TUBE BOTTLE MOUNT**
FLASCHE SITTELROHR
-  **DOWNTUBE BOTTLE MOUNT**
FLASCHE UNTERROHR

| | STL | CSL | TTL | HTL | HTA | STA | BB | WB | ST | RE | SOH |  |  |  |  |  |  |  |  |  |  |  |  |  |  | | |
|--------------------|-----|-----|-----|-----|-----|-----|----|-----|-----|-----|-----|---|---|---|---|---|---|---|---|---|---|---|---|---|---|---|---|
| POWERKID 16 | | | | | | | | | | | | | | | | | | | | | | | | | | | |
| 16 | 230 | 315 | 367 | 100 | 71 | 73 | 3 | 737 | 356 | 273 | 391 | 30/30 | 110/100 | BSA 68 | 27.2 | -/- | 0 | 0 | 0 | 0 | 40 | 460 | 114 | - | - | - | - |
| POWERKID 12 | | | | | | | | | | | | | | | | | | | | | | | | | | | |
| 12 | 180 | 262 | 302 | 100 | 71 | 73 | 10 | 612 | 292 | 225 | 335 | 30/30 | 110/100 | BSA 68 | 27.2 | -/- | 0 | 0 | 0 | 0 | 40 | 460 | 89 | - | - | - | - |

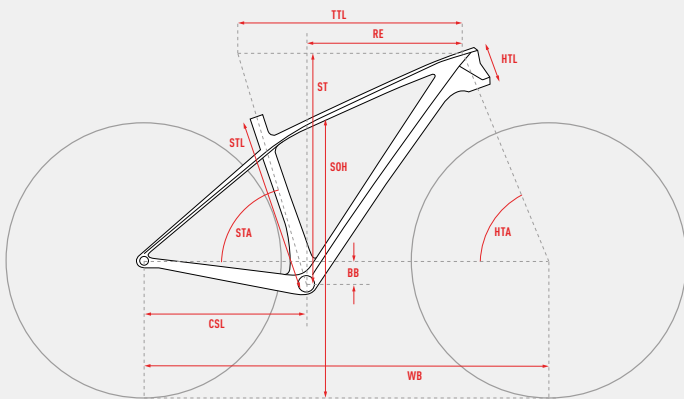

POWERKIDDY



ALL DIMENSIONS IN MM (EXCEPT HTA AND STA IN °)

ALLE MASSE IN MM (AUSNAHME HTA UND STA IN °)

- STL** SEAT TUBE LENGTH
SITZROHRLÄNGE
- CSL** CHAINSTAY LENGTH
KETTENSTREBELÄNGE
- TTL** TOP TUBE LENGTH
OBERROHRLÄNGE
- HTL** HEAD TUBE LENGTH
STEUERROHRLÄNGE
- HTA** HEAD TUBE ANGLE
STEUERROHRWINKEL
- STA** SEAT TUBE ANGLE
SITZROHRWINKEL
- BB** BOTTOM BRACKET DROP
INNENLAGERABSENKUNG
- WB** WHEELBASE
RADSTAND
- ST** STACK
STACK
- RE** REACH
REACH
- SOH** STANDOVER HEIGHT
ÜBERSTANDSHÖHE
-  **HEAD SET DIAMETER (UPPER / LOWER)**
STEUERSATZDURCHMESSER (OBEN / UNTEN)

-  **AXLE STANDARD (REAR / FRONT)**
ACHSENSTANDARD (HINTEN / VORNE)
-  **BOTTOM BRACKET STANDARD**
TRETLAGERSTANDARD
-  **SEAT POST DIAMETER**
SITTELSTÜTZENDURCHMESSER
-  **SHOCK HARDWARE (Ø 8 MM)**
DÄMPFERBUCHSENMASSE (Ø 8 MM)
-  **SHOCK LENGTH**
DÄMPFEREINBAULÄNGE
-  **SHOCK TRAVEL**
DÄMPFERHUB
-  **FRONT FORK TRAVEL**
FEDERWEG VORNE
-  **REAR WHEEL TRAVEL**
FEDERWEG HINTEN
-  **STEM LENGTH**
VORBAULÄNGE
-  **HANDLEBAR WIDTH**
LENKERBREITE
-  **CRANK LENGTH**
KURBELLENGE
-  **SEAT TUBE BOTTLE MOUNT**
FLASCHE SITTELROHR
-  **DOWNTUBE BOTTLE MOUNT**
FLASCHE UNTERROHR

| | STL | CSL | TTL | HTL | HTA | STA | BB | WB | ST | RE | SOH |  |  |  |  |  |  |  |  |  |  |  |  |  |  | | |
|----------------------|-----|-----|-----|-----|-----|------|----|-----|-----|-----|-----|---|---|---|---|---|---|---|---|---|---|---|---|---|---|---|--|
| POWERKIDDY 12 | | | | | | | | | | | | | | | | | | | | | | | | | | | |
| 12 | 190 | 240 | 293 | 70 | 70 | 75.9 | 0 | 595 | 257 | 236 | 310 | 30/30 | 100/100 | | | | | | | | 40 | 460 | - | - | - | - | |



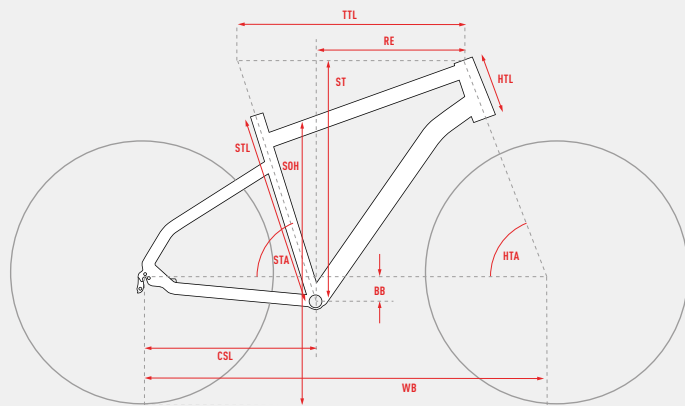



SQUARE^{CROSS}

























ALL DIMENSIONS IN MM (EXCEPT HTA AND STA IN °)















ALLE MASSE IN MM (AUSNAHME HTA UND STA IN °)

- STL** SEAT TUBE LENGTH
SITZROHRLÄNGE
- CSL** CHAINSTAY LENGTH
KETTENSTREBENLÄNGE
- TTL** TOP TUBE LENGTH
OBERROHRLÄNGE
- HTL** HEAD TUBE LENGTH
STEUERROHRLÄNGE
- HTA** HEAD TUBE ANGLE
STEUERROHRWINKEL
- STA** SEAT TUBE ANGLE
SITZROHRWINKEL
- BB** BOTTOM BRACKET DROP
INNENLAGERABSENKUNG
- WB** WHEELBASE
RADSTAND
- ST** STACK
STACK
- RE** REACH
REACH
- SOH** STANDOVER HEIGHT
ÜBERSTANDSHÖHE
-  HEAD SET DIAMETER (UPPER / LOWER)
STEUERSATZDURCHMESSER (OBEN / UNTEN)
-  AXLE STANDARD (REAR / FRONT)
ACHSENSTANDARD (HINTEN / VORNE)
-  BOTTOM BRACKET STANDARD
TRETLAGERSTANDARD
-  SEAT POST DIAMETER
SÄTTELSTÜTZENDURCHMESSER
-  SHOCK HARDWARE (Ø 8 MM)
DÄMPFERBUCHSENMASSE (Ø 8 MM)
-  SHOCK LENGTH
DÄMPFEREINBAULÄNGE
-  SHOCK TRAVEL
DÄMPFERHUB
-  FRONT FORK TRAVEL
FEDERWEG VORNE
-  REAR WHEEL TRAVEL
FEDERWEG HINTEN
-  STEM LENGTH
VORBAULÄNGE
-  HANDLEBAR WIDTH
LENKERBREITE
-  CRANK LENGTH
KURBELLÄNGE
-  SEAT TUBE BOTTLE MOUNT
FLASCHE SÄTTELROHR
-  DOWNTUBE BOTTLE MOUNT
FLASCHE UNTERROHR

| | STL | CSL | TTL | HTL | HTA | STA | BB | WB | ST | RE | SOH |  |  |  |  |  |  |  |  |  |  |  |  |  |  | | |
|-------------------------------|-----|-----|-----|-----|-----|------|----|------|-----|-----|-----|---|---|---|---|---|---|---|---|---|---|---|---|---|---|--|--|
| SQUARE CROSS ESSENTIAL | | | | | | | | | | | | | | | | | | | | | | | | | | | |
| S | 470 | 455 | 580 | 160 | 70 | 73.5 | 60 | 1105 | 636 | 391 | 735 | 44 / 56 | 135/100 | BSA 68 | 31.6 | - / - | 0 | 0 | 65 | 0 | 75 | 680 | 175 | 0.75 | 0.75 | | |
| M | 520 | 455 | 595 | 165 | 70 | 72.5 | 60 | 1108 | 641 | 393 | 770 | 44 / 56 | 135/100 | BSA 68 | 31.6 | - / - | 0 | 0 | 65 | 0 | 75 | 680 | 175 | 0.75 | 0.75 | | |
| L | 570 | 455 | 610 | 185 | 71 | 72.5 | 60 | 1112 | 664 | 400 | 815 | 44 / 56 | 135/100 | BSA 68 | 31.6 | - / - | 0 | 0 | 65 | 0 | 75 | 680 | 175 | 0.75 | 0.75 | | |
| XL | 620 | 455 | 625 | 205 | 71 | 72 | 60 | 1121 | 683 | 403 | 855 | 44 / 56 | 135/100 | BSA 68 | 31.6 | - / - | 0 | 0 | 65 | 0 | 75 | 680 | 175 | 0.75 | 0.75 | | |

| | STL | CSL | TTL | HTL | HTA | STA | BB | WB | ST | RE | SOH |  |  |  |  |  |  |  |  |  |  |  |  |  |  | | |
|---------------------------------|-----|-----|-----|-----|------|-----|----|------|-----|-----|-----|---|---|---|---|---|---|---|---|---|---|---|---|---|---|--|--|
| SQUARE CROSS ESSENTIAL W | | | | | | | | | | | | | | | | | | | | | | | | | | | |
| XS | 420 | 455 | 560 | 150 | 70.5 | 73 | 60 | 1073 | 629 | 368 | 630 | 44 / 56 | 135/100 | BSA 68 | 31.6 | - / - | 0 | 0 | 65 | 0 | 75 | 680 | 175 | - | 0.75 | | |
| S | 470 | 455 | 575 | 155 | 70.5 | 72 | 60 | 1076 | 634 | 369 | 625 | 44 / 56 | 135/100 | BSA 68 | 31.6 | - / - | 0 | 0 | 65 | 0 | 75 | 680 | 175 | - | 0.75 | | |
| M | 520 | 455 | 590 | 170 | 70.5 | 72 | 60 | 1091 | 648 | 379 | 625 | 44 / 56 | 135/100 | BSA 68 | 31.6 | - / - | 0 | 0 | 65 | 0 | 75 | 680 | 175 | - | 0.75 | | |
| L | 560 | 455 | 610 | 185 | 70.5 | 72 | 60 | 1112 | 662 | 395 | 625 | 44 / 56 | 135/100 | BSA 68 | 31.6 | - / - | 0 | 0 | 65 | 0 | 75 | 680 | 175 | - | 0.75 | | |

| | STL | CSL | TTL | HTL | HTA | STA | BB | WB | ST | RE | SOH |  |  |  |  |  |  |  |  |  |  |  |  |  |  | | |
|--------------------------|-----|-----|-----|-----|-----|------|----|------|-----|-----|-----|---|---|---|---|---|---|---|---|---|---|---|---|---|---|--|--|
| SQUARE CROSS BASE | | | | | | | | | | | | | | | | | | | | | | | | | | | |
| S | 470 | 455 | 580 | 160 | 70 | 73.5 | 60 | 1105 | 636 | 391 | 735 | 44 / 56 | 135/100 | BSA 68 | 31.6 | - / - | 0 | 0 | 63 | 0 | 75 | 680 | 175 | 0.75 | 0.75 | | |
| M | 520 | 455 | 595 | 165 | 70 | 72.5 | 60 | 1108 | 641 | 393 | 770 | 44 / 56 | 135/100 | BSA 68 | 31.6 | - / - | 0 | 0 | 63 | 0 | 75 | 680 | 175 | 0.75 | 0.75 | | |
| L | 570 | 455 | 610 | 185 | 71 | 72.5 | 60 | 1112 | 664 | 400 | 815 | 44 / 56 | 135/100 | BSA 68 | 31.6 | - / - | 0 | 0 | 63 | 0 | 75 | 680 | 175 | 0.75 | 0.75 | | |
| XL | 620 | 455 | 625 | 205 | 71 | 72 | 60 | 1121 | 683 | 403 | 855 | 44 / 56 | 135/100 | BSA 68 | 31.6 | - / - | 0 | 0 | 63 | 0 | 75 | 680 | 175 | 0.75 | 0.75 | | |

| | STL | CSL | TTL | HTL | HTA | STA | BB | WB | ST | RE | SOH |  |  |  |  |  |  |  |  |  |  |  |  |  |  | | |
|----------------------------|-----|-----|-----|-----|------|-----|----|------|-----|-----|-----|---|---|---|---|---|---|---|---|---|---|---|---|---|---|--|--|
| SQUARE CROSS BASE W | | | | | | | | | | | | | | | | | | | | | | | | | | | |
| XS | 420 | 455 | 560 | 150 | 70.5 | 73 | 60 | 1073 | 629 | 368 | 630 | 44 / 56 | 135/100 | BSA 68 | 31.6 | - / - | 0 | 0 | 63 | 0 | 75 | 680 | 175 | - | 0.75 | | |
| S | 470 | 455 | 575 | 155 | 70.5 | 72 | 60 | 1076 | 634 | 369 | 625 | 44 / 56 | 135/100 | BSA 68 | 31.6 | - / - | 0 | 0 | 63 | 0 | 75 | 680 | 175 | - | 0.75 | | |
| M | 520 | 455 | 590 | 170 | 70.5 | 72 | 60 | 1091 | 648 | 379 | 625 | 44 / 56 | 135/100 | BSA 68 | 31.6 | - / - | 0 | 0 | 63 | 0 | 75 | 680 | 175 | - | 0.75 | | |
| L | 560 | 455 | 610 | 185 | 70.5 | 72 | 60 | 1112 | 662 | 395 | 625 | 44 / 56 | 135/100 | BSA 68 | 31.6 | - / - | 0 | 0 | 63 | 0 | 75 | 680 | 175 | - | 0.75 | | |

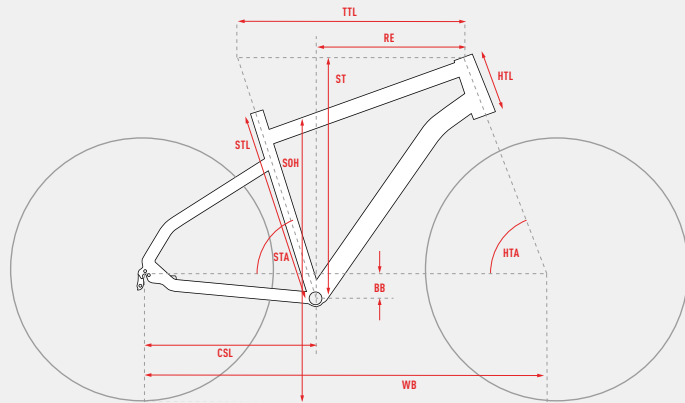

SQUARE TREKKING























ALL DIMENSIONS IN MM (EXCEPT HTA AND STA IN °)











ALLE MASSE IN MM (AUSNAHME HTA UND STA IN °)

- STL** SEAT TUBE LENGTH
SITZROHRLÄNGE
- CSL** CHAINSTAY LENGTH
KETTENSTREBENLÄNGE
- TTL** TOP TUBE LENGTH
OBERROHRLÄNGE
- HTL** HEAD TUBE LENGTH
STEUERROHRLÄNGE
- HTA** HEAD TUBE ANGLE
STEUERROHRWINKEL
- STA** SEAT TUBE ANGLE
SITZROHRWINKEL
- BB** BOTTOM BRACKET DROP
INNENLAGERABSENKUNG
- WB** WHEELBASE
RADSTAND
- ST** STACK
STACK
- RE** REACH
REACH
- SOH** STANDOVER HEIGHT
ÜBERSTANDSHÖHE
-  HEAD SET DIAMETER (UPPER / LOWER)
STEUERSATZDURCHMESSER (OBEN / UNTEN)

-  AXLE STANDARD (REAR / FRONT)
ACHSENSTANDARD (HINTEN / VORNE)
-  BOTTOM BRACKET STANDARD
TRETLAGERSTANDARD
-  SEAT POST DIAMETER
SATTELSTÜTZENDURCHMESSER
-  SHOCK HARDWARE (Ø 8 MM)
DÄMPFERBUCHSENMASSE (Ø 8 MM)
-  SHOCK LENGTH
DÄMPFEREINBAULÄNGE
-  SHOCK TRAVEL
DÄMPFERHUB
-  FRONT FORK TRAVEL
FEDERWEG VORNE
-  REAR WHEEL TRAVEL
FEDERWEG HINTEN
-  STEM LENGTH
VORBAULÄNGE
-  HANDLEBAR WIDTH
LENKERBREITE
-  CRANK LENGTH
KURBELLÄNGE
-  SEAT TUBE BOTTLE MOUNT
FLASCHE SATTELROHR
-  DOWNTUBE BOTTLE MOUNT
FLASCHE UNTERROHR

| | STL | CSL | TTL | HTL | HTA | STA | BB | WB | ST | RE | SOH |  |  |  |  |  |  |  |  |  |  |  |  |  |  | | |
|----------------------------------|-----|-----|-----|-----|-----|------|----|------|-----|-----|-----|---|---|---|---|---|---|---|---|---|---|---|---|---|---|--|--|
| SQUARE TREKKING ESSENTIAL | | | | | | | | | | | | | | | | | | | | | | | | | | | |
| S | 470 | 455 | 580 | 160 | 70 | 73.5 | 60 | 1105 | 636 | 391 | 735 | 44 / 56 | 135/100 | BSA 68 | 31.6 | - / - | 0 | 0 | 63 | 0 | 75 | 680 | 175 | 0.75 | 0.75 | | |
| M | 520 | 455 | 595 | 165 | 70 | 72.5 | 60 | 1108 | 641 | 393 | 770 | 44 / 56 | 135/100 | BSA 68 | 31.6 | - / - | 0 | 0 | 63 | 0 | 75 | 680 | 175 | 0.75 | 0.75 | | |
| L | 570 | 455 | 610 | 185 | 71 | 72.5 | 60 | 1112 | 664 | 400 | 815 | 44 / 56 | 135/100 | BSA 68 | 31.6 | - / - | 0 | 0 | 63 | 0 | 75 | 680 | 175 | 0.75 | 0.75 | | |
| XL | 620 | 455 | 625 | 205 | 71 | 72 | 60 | 1121 | 683 | 403 | 855 | 44 / 56 | 135/100 | BSA 68 | 31.6 | - / - | 0 | 0 | 63 | 0 | 75 | 680 | 175 | 0.75 | 0.75 | | |

| | STL | CSL | TTL | HTL | HTA | STA | BB | WB | ST | RE | SOH |  |  |  |  |  |  |  |  |  |  |  |  |  |  | | |
|------------------------------------|-----|-----|-----|-----|------|-----|----|------|-----|-----|-----|---|---|---|---|---|---|---|---|---|---|---|---|---|---|--|--|
| SQUARE TREKKING ESSENTIAL W | | | | | | | | | | | | | | | | | | | | | | | | | | | |
| XS | 420 | 455 | 560 | 150 | 70.5 | 73 | 60 | 1073 | 629 | 368 | 630 | 44 / 56 | 135/100 | BSA 68 | 31.6 | - / - | 0 | 0 | 63 | 0 | 75 | 680 | 175 | - | 0.75 | | |
| S | 470 | 455 | 575 | 155 | 70.5 | 72 | 60 | 1076 | 634 | 369 | 625 | 44 / 56 | 135/100 | BSA 68 | 31.6 | - / - | 0 | 0 | 63 | 0 | 75 | 680 | 175 | - | 0.75 | | |
| M | 520 | 455 | 590 | 170 | 70.5 | 72 | 60 | 1091 | 648 | 379 | 625 | 44 / 56 | 135/100 | BSA 68 | 31.6 | - / - | 0 | 0 | 63 | 0 | 75 | 680 | 175 | - | 0.75 | | |
| L | 560 | 455 | 610 | 185 | 70.5 | 72 | 60 | 1112 | 662 | 395 | 625 | 44 / 56 | 135/100 | BSA 68 | 31.6 | - / - | 0 | 0 | 63 | 0 | 75 | 680 | 175 | - | 0.75 | | |

| | STL | CSL | TTL | HTL | HTA | STA | BB | WB | ST | RE | SOH |  |  |  |  |  |  |  |  |  |  |  |  |  |  | | |
|-----------------------------|-----|-----|-----|-----|-----|------|----|------|-----|-----|-----|---|---|---|---|---|---|---|---|---|---|---|---|---|---|--|--|
| SQUARE TREKKING BASE | | | | | | | | | | | | | | | | | | | | | | | | | | | |
| S | 470 | 455 | 580 | 160 | 70 | 73.5 | 60 | 1105 | 636 | 391 | 735 | 44 / 56 | 135/100 | BSA 68 | 31.6 | - / - | 0 | 0 | 63 | 0 | 75 | 680 | 175 | 0.75 | 0.75 | | |
| M | 520 | 455 | 595 | 165 | 70 | 72.5 | 60 | 1108 | 641 | 393 | 770 | 44 / 56 | 135/100 | BSA 68 | 31.6 | - / - | 0 | 0 | 63 | 0 | 75 | 680 | 175 | 0.75 | 0.75 | | |
| L | 570 | 455 | 610 | 185 | 71 | 72.5 | 60 | 1112 | 664 | 400 | 815 | 44 / 56 | 135/100 | BSA 68 | 31.6 | - / - | 0 | 0 | 63 | 0 | 75 | 680 | 175 | 0.75 | 0.75 | | |
| XL | 620 | 455 | 625 | 205 | 71 | 72 | 60 | 1121 | 683 | 403 | 855 | 44 / 56 | 135/100 | BSA 68 | 31.6 | - / - | 0 | 0 | 63 | 0 | 75 | 680 | 175 | 0.75 | 0.75 | | |

| | STL | CSL | TTL | HTL | HTA | STA | BB | WB | ST | RE | SOH |  |  |  |  |  |  |  |  |  |  |  |  |  |  | | |
|-------------------------------|-----|-----|-----|-----|------|-----|----|------|-----|-----|-----|---|---|---|---|---|---|---|---|---|---|---|---|---|---|--|--|
| SQUARE TREKKING BASE W | | | | | | | | | | | | | | | | | | | | | | | | | | | |
| XS | 420 | 455 | 560 | 150 | 70.5 | 73 | 60 | 1073 | 629 | 368 | 630 | 44 / 56 | 135/100 | BSA 68 | 31.6 | - / - | 0 | 0 | 63 | 0 | 75 | 680 | 175 | - | 0.75 | | |
| S | 470 | 455 | 575 | 155 | 70.5 | 72 | 60 | 1076 | 634 | 369 | 625 | 44 / 56 | 135/100 | BSA 68 | 31.6 | - / - | 0 | 0 | 63 | 0 | 75 | 680 | 175 | - | 0.75 | | |
| M | 520 | 455 | 590 | 170 | 70.5 | 72 | 60 | 1091 | 648 | 379 | 625 | 44 / 56 | 135/100 | BSA 68 | 31.6 | - / - | 0 | 0 | 63 | 0 | 75 | 680 | 175 | - | 0.75 | | |
| L | 560 | 455 | 610 | 185 | 70.5 | 72 | 60 | 1112 | 662 | 395 | 625 | 44 / 56 | 135/100 | BSA 68 | 31.6 | - / - | 0 | 0 | 63 | 0 | 75 | 680 | 175 | - | 0.75 | | |

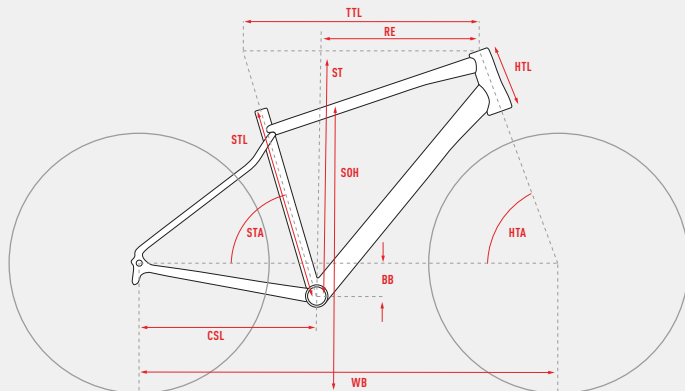

ALL DIMENSIONS IN MM (EXCEPT HTA AND STA IN °)

ALLE MASSE IN MM (AUSNAHME HTA UND STA IN °)

- STL** SEAT TUBE LENGTH
SITZROHRLÄNGE
- CSL** CHAINSTAY LENGTH
KETTENSTREBENLÄNGE
- TTL** TOP TUBE LENGTH
OBERROHRLÄNGE
- HTL** HEAD TUBE LENGTH
STEUERROHRLÄNGE
- HTA** HEAD TUBE ANGLE
STEUERROHRWINKEL
- STA** SEAT TUBE ANGLE
SITZROHRWINKEL
- BB** BOTTOM BRACKET DROP
INNENLAGERABSENKUNG
- WB** WHEELBASE
RADSTAND
- ST** STACK
STACK
- RE** REACH
REACH
- SOH** STANDOVER HEIGHT
ÜBERSTANDSHÖHE
- HEAD SET DIAMETER (UPPER / LOWER)
STEUERSATZDURCHMESSER (OBEN / UNTEN)

- AXLE STANDARD (REAR / FRONT)
ACHSENSTANDARD (HINTEN / VORNE)
- BOTTOM BRACKET STANDARD
TRETLAGERSTANDARD
- SEAT POST DIAMETER
SÄTTELSTÜTZENDURCHMESSER
- SHOCK HARDWARE (Ø 8 MM)
DÄMPFERBUCHSENMASSE (Ø 8 MM)
- SHOCK LENGTH
DÄMPFERBAULÄNGE
- SHOCK TRAVEL
DÄMPFERHUB
- FRONT FORK TRAVEL
FEDERWEG VORNE
- REAR WHEEL TRAVEL
FEDERWEG HINTEN
- STEM LENGTH
VORBAULÄNGE
- HANDLEBAR WIDTH
LENKERBREITE
- CRANK LENGTH
KURBELLÄNGE
- SEAT TUBE BOTTLE MOUNT
FLASCHE SÄTTELROHR
- DOWNTUBE BOTTLE MOUNT
FLASCHE UNTERROHR

| | STL | CSL | TTL | HTL | HTA | STA | BB | WB | ST | RE | SOH | | | | | | | | | | | | | | |
|------------------------|-----|-----|-----|-----|------|------|------|------|-----|-----|-----|-------|---------|------|-------|---|---|---|---|---|----|-----|-------|------|------|
| ASKET ADVANCED | | | | | | | | | | | | | | | | | | | | | | | | | |
| XS | 410 | 440 | 535 | 100 | 69.5 | 73.8 | 71.6 | 1049 | 558 | 373 | 680 | 0 / 0 | 142/100 | 27.2 | - / - | 0 | 0 | 0 | 0 | 0 | 60 | 420 | 170 | 0.5 | 0.6 |
| S | 450 | 440 | 563 | 130 | 69.8 | 73.7 | 71.5 | 1076 | 587 | 392 | 710 | 0 / 0 | 142/100 | 27.2 | - / - | 0 | 0 | 0 | 0 | 0 | 60 | 440 | 170 | 0.6 | 0.6 |
| M | 485 | 440 | 586 | 160 | 70.1 | 73.7 | 66.5 | 1098 | 612 | 407 | 750 | 0 / 0 | 142/100 | 27.2 | - / - | 0 | 0 | 0 | 0 | 0 | 60 | 460 | 172.5 | 0.75 | 0.75 |
| L | 525 | 440 | 615 | 190 | 70.4 | 73.6 | 66.5 | 1126 | 641 | 427 | 780 | 0 / 0 | 142/100 | 27.2 | - / - | 0 | 0 | 0 | 0 | 0 | 60 | 480 | 175 | 0.75 | 0.75 |
| XL | 560 | 440 | 639 | 220 | 70.7 | 73.6 | 61.5 | 1150 | 666 | 444 | 820 | 0 / 0 | 142/100 | 27.2 | - / - | 0 | 0 | 0 | 0 | 0 | 60 | 500 | 175 | 0.75 | 0.75 |
| ASKET ESSENTIAL | | | | | | | | | | | | | | | | | | | | | | | | | |
| XS | 410 | 440 | 535 | 100 | 69.5 | 73.8 | 71.6 | 1049 | 558 | 373 | 680 | 0 / 0 | 142/100 | 27.2 | - / - | 0 | 0 | 0 | 0 | 0 | 60 | 420 | 170 | 0.5 | 0.6 |
| S | 450 | 440 | 563 | 130 | 69.8 | 73.7 | 71.5 | 1076 | 587 | 392 | 710 | 0 / 0 | 142/100 | 27.2 | - / - | 0 | 0 | 0 | 0 | 0 | 60 | 440 | 170 | 0.6 | 0.6 |
| M | 485 | 440 | 586 | 160 | 70.1 | 73.7 | 66.5 | 1098 | 612 | 407 | 750 | 0 / 0 | 142/100 | 27.2 | - / - | 0 | 0 | 0 | 0 | 0 | 60 | 460 | 172.5 | 0.75 | 0.75 |
| L | 525 | 440 | 615 | 190 | 70.4 | 73.6 | 66.5 | 1126 | 641 | 427 | 780 | 0 / 0 | 142/100 | 27.2 | - / - | 0 | 0 | 0 | 0 | 0 | 60 | 480 | 175 | 0.75 | 0.75 |
| XL | 560 | 440 | 639 | 220 | 70.7 | 73.6 | 61.5 | 1150 | 666 | 444 | 820 | 0 / 0 | 142/100 | 27.2 | - / - | 0 | 0 | 0 | 0 | 0 | 60 | 500 | 175 | 0.75 | 0.75 |
| ASKET | | | | | | | | | | | | | | | | | | | | | | | | | |
| XS | 410 | 440 | 535 | 100 | 69.5 | 73.8 | 71.6 | 1049 | 558 | 373 | 680 | 0 / 0 | 142/100 | 27.2 | - / - | 0 | 0 | 0 | 0 | 0 | 60 | 420 | 170 | 0.5 | 0.6 |
| S | 450 | 440 | 563 | 130 | 69.8 | 73.7 | 71.5 | 1076 | 587 | 392 | 710 | 0 / 0 | 142/100 | 27.2 | - / - | 0 | 0 | 0 | 0 | 0 | 60 | 440 | 170 | 0.6 | 0.6 |
| M | 485 | 440 | 586 | 160 | 70.1 | 73.7 | 66.5 | 1098 | 612 | 407 | 750 | 0 / 0 | 142/100 | 27.2 | - / - | 0 | 0 | 0 | 0 | 0 | 60 | 460 | 172.5 | 0.75 | 0.75 |
| L | 525 | 440 | 615 | 190 | 70.4 | 73.6 | 66.5 | 1126 | 641 | 427 | 780 | 0 / 0 | 142/100 | 27.2 | - / - | 0 | 0 | 0 | 0 | 0 | 60 | 480 | 175 | 0.75 | 0.75 |
| XL | 560 | 440 | 639 | 220 | 70.7 | 73.6 | 61.5 | 1150 | 666 | 444 | 820 | 0 / 0 | 142/100 | 27.2 | - / - | 0 | 0 | 0 | 0 | 0 | 60 | 500 | 175 | 0.75 | 0.75 |
| URBAN ASKET | | | | | | | | | | | | | | | | | | | | | | | | | |
| XS | 410 | 440 | 535 | 100 | 69.5 | 73.8 | 71.6 | 1049 | 558 | 373 | 680 | 0 / 0 | 142/100 | 27.2 | - / - | 0 | 0 | 0 | 0 | 0 | 60 | 660 | 170 | 0.5 | 0.6 |
| S | 450 | 440 | 563 | 130 | 69.8 | 73.7 | 71.5 | 1076 | 587 | 392 | 710 | 0 / 0 | 142/100 | 27.2 | - / - | 0 | 0 | 0 | 0 | 0 | 60 | 660 | 170 | 0.6 | 0.6 |
| M | 485 | 440 | 586 | 160 | 70.1 | 73.7 | 66.5 | 1098 | 612 | 407 | 750 | 0 / 0 | 142/100 | 27.2 | - / - | 0 | 0 | 0 | 0 | 0 | 60 | 660 | 172.5 | 0.75 | 0.75 |
| L | 525 | 440 | 615 | 190 | 70.4 | 73.6 | 66.5 | 1126 | 641 | 427 | 780 | 0 / 0 | 142/100 | 27.2 | - / - | 0 | 0 | 0 | 0 | 0 | 60 | 660 | 175 | 0.75 | 0.75 |
| XL | 560 | 440 | 639 | 220 | 70.7 | 73.6 | 61.5 | 1150 | 666 | 444 | 820 | 0 / 0 | 142/100 | 27.2 | - / - | 0 | 0 | 0 | 0 | 0 | 60 | 660 | 175 | 0.75 | 0.75 |

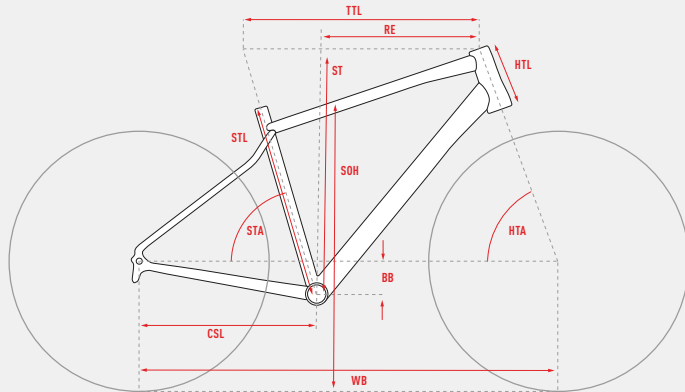

ALL DIMENSIONS IN MM (EXCEPT HTA AND STA IN °)

ALLE MASSE IN MM (AUSNAHME HTA UND STA IN °)

- STL** SEAT TUBE LENGTH
SITZROHRLÄNGE
- CSL** CHAINSTAY LENGTH
KETTENSTREBELÄNGE
- TTL** TOP TUBE LENGTH
OBERROHRLÄNGE
- HTL** HEAD TUBE LENGTH
STEUERROHRLÄNGE
- HTA** HEAD TUBE ANGLE
STEUERROHRWINKEL
- STA** SEAT TUBE ANGLE
SITZROHRWINKEL
- BB** BOTTOM BRACKET DROP
INNENLAGERABSSENKUNG
- WB** WHEELBASE
RADSTAND
- ST** STACK
STACK
- RE** REACH
REACH
- SOH** STANDOVER HEIGHT
ÜBERSTANDSHÖHE
- HEAD SET DIAMETER (UPPER / LOWER)
STEUERSATZDURCHMESSER (OBEN / UNTEN)
- AXLE STANDARD (REAR / FRONT)
ACHSENSTANDARD (HINTEN / VORNE)
- BOTTOM BRACKET STANDARD
TRETLAGERSTANDARD
- SEAT POST DIAMETER
SÄTTELSTÜTZENDURCHMESSER
- SHOCK HARDWARE (Ø 8 MM)
DÄMPFERBUCHSENMASSE (Ø 8 MM)
- SHOCK LENGTH
DÄMPFERENBAULÄNGE
- SHOCK TRAVEL
DÄMPFERHUB
- FRONT FORK TRAVEL
FEDERWEG VORNE
- REAR WHEEL TRAVEL
FEDERWEG HINTEN
- STEM LENGTH
VORBAULÄNGE
- HANDLEBAR WIDTH
LENKERBREITE
- CRANK LENGTH
KURBELLÄNGE
- SEAT TUBE BOTTLE MOUNT
FLASCHE SÄTTELROHR
- DOWNTUBE BOTTLE MOUNT
FLASCHE UNTERROHR

STL CSL TTL HTL HTA STA BB WB ST RE SOH

ASKET ADVANCED EQ

| | | | | | | | | | | | | | | | | | | | | | | | | | |
|----|-----|-----|-----|-----|------|------|------|------|-----|-----|-----|-------|---------|------|-------|---|---|---|---|---|----|-----|-------|------|------|
| XS | 410 | 440 | 535 | 100 | 69.5 | 73.8 | 71.6 | 1049 | 558 | 373 | 680 | 0 / 0 | 142/100 | 27.2 | - / - | 0 | 0 | 0 | 0 | 0 | 60 | 420 | 170 | 0.5 | 0.6 |
| S | 450 | 440 | 563 | 130 | 69.8 | 73.7 | 71.5 | 1076 | 587 | 392 | 710 | 0 / 0 | 142/100 | 27.2 | - / - | 0 | 0 | 0 | 0 | 0 | 60 | 440 | 170 | 0.6 | 0.6 |
| M | 485 | 440 | 586 | 160 | 70.1 | 73.7 | 66.5 | 1098 | 612 | 407 | 750 | 0 / 0 | 142/100 | 27.2 | - / - | 0 | 0 | 0 | 0 | 0 | 60 | 460 | 172.5 | 0.75 | 0.75 |
| L | 525 | 440 | 615 | 190 | 70.4 | 73.6 | 66.5 | 1126 | 641 | 427 | 780 | 0 / 0 | 142/100 | 27.2 | - / - | 0 | 0 | 0 | 0 | 0 | 60 | 480 | 175 | 0.75 | 0.75 |
| XL | 560 | 440 | 639 | 220 | 70.7 | 73.6 | 61.5 | 1150 | 666 | 444 | 820 | 0 / 0 | 142/100 | 27.2 | - / - | 0 | 0 | 0 | 0 | 0 | 60 | 500 | 175 | 0.75 | 0.75 |

STL CSL TTL HTL HTA STA BB WB ST RE SOH

ASKET ESSENTIAL EQ

| | | | | | | | | | | | | | | | | | | | | | | | | | |
|----|-----|-----|-----|-----|------|------|------|------|-----|-----|-----|-------|---------|------|-------|---|---|---|---|---|----|-----|-------|------|------|
| XS | 410 | 440 | 535 | 100 | 69.5 | 73.8 | 71.6 | 1049 | 558 | 373 | 680 | 0 / 0 | 142/100 | 27.2 | - / - | 0 | 0 | 0 | 0 | 0 | 60 | 420 | 170 | 0.5 | 0.6 |
| S | 450 | 440 | 563 | 130 | 69.8 | 73.7 | 71.5 | 1076 | 587 | 392 | 710 | 0 / 0 | 142/100 | 27.2 | - / - | 0 | 0 | 0 | 0 | 0 | 60 | 440 | 170 | 0.6 | 0.6 |
| M | 485 | 440 | 586 | 160 | 70.1 | 73.7 | 66.5 | 1098 | 612 | 407 | 750 | 0 / 0 | 142/100 | 27.2 | - / - | 0 | 0 | 0 | 0 | 0 | 60 | 460 | 172.5 | 0.75 | 0.75 |
| L | 525 | 440 | 615 | 190 | 70.4 | 73.6 | 66.5 | 1126 | 641 | 427 | 780 | 0 / 0 | 142/100 | 27.2 | - / - | 0 | 0 | 0 | 0 | 0 | 60 | 480 | 175 | 0.75 | 0.75 |
| XL | 560 | 440 | 639 | 220 | 70.7 | 73.6 | 61.5 | 1150 | 666 | 444 | 820 | 0 / 0 | 142/100 | 27.2 | - / - | 0 | 0 | 0 | 0 | 0 | 60 | 500 | 175 | 0.75 | 0.75 |

STL CSL TTL HTL HTA STA BB WB ST RE SOH

ASKET EQ

| | | | | | | | | | | | | | | | | | | | | | | | | | |
|----|-----|-----|-----|-----|------|------|------|------|-----|-----|-----|-------|---------|------|-------|---|---|---|---|---|----|-----|-------|------|------|
| XS | 410 | 440 | 535 | 100 | 69.5 | 73.8 | 71.6 | 1049 | 558 | 373 | 680 | 0 / 0 | 142/100 | 27.2 | - / - | 0 | 0 | 0 | 0 | 0 | 60 | 420 | 170 | 0.5 | 0.6 |
| S | 450 | 440 | 563 | 130 | 69.8 | 73.7 | 71.5 | 1076 | 587 | 392 | 710 | 0 / 0 | 142/100 | 27.2 | - / - | 0 | 0 | 0 | 0 | 0 | 60 | 440 | 170 | 0.6 | 0.6 |
| M | 485 | 440 | 586 | 160 | 70.1 | 73.7 | 66.5 | 1098 | 612 | 407 | 750 | 0 / 0 | 142/100 | 27.2 | - / - | 0 | 0 | 0 | 0 | 0 | 60 | 460 | 172.5 | 0.75 | 0.75 |
| L | 525 | 440 | 615 | 190 | 70.4 | 73.6 | 66.5 | 1126 | 641 | 427 | 780 | 0 / 0 | 142/100 | 27.2 | - / - | 0 | 0 | 0 | 0 | 0 | 60 | 480 | 175 | 0.75 | 0.75 |
| XL | 560 | 440 | 639 | 220 | 70.7 | 73.6 | 61.5 | 1150 | 666 | 444 | 820 | 0 / 0 | 142/100 | 27.2 | - / - | 0 | 0 | 0 | 0 | 0 | 60 | 500 | 175 | 0.75 | 0.75 |

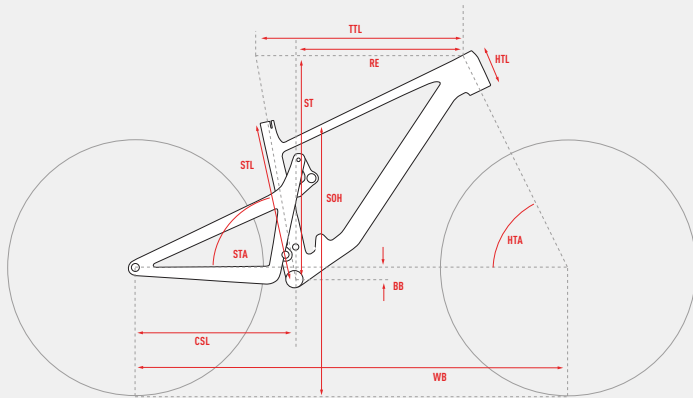

ALL DIMENSIONS IN MM (EXCEPT HTA AND STA IN °)

ALLE MASSE IN MM (AUSNAHME HTA UND STA IN °)

- STL** SEAT TUBE LENGTH
SITZROHRLÄNGE
- CSL** CHAINSTAY LENGTH
KETTENSTREBENLÄNGE
- TTL** TOP TUBE LENGTH
OBERROHRLÄNGE
- HTL** HEAD TUBE LENGTH
STEUERROHRLÄNGE
- HTA** HEAD TUBE ANGLE
STEUERROHRWINKEL
- STA** SEAT TUBE ANGLE
SITZROHRWINKEL
- BB** BOTTOM BRACKET DROP
INNENLAGERABSENKUNG
- WB** WHEELBASE
RADSTAND
- ST** STACK
STACK
- RE** REACH
REACH
- SOH** STANDOVER HEIGHT
ÜBERSTANDSHÖHE
- HEAD SET DIAMETER (UPPER / LOWER)
STEUERSATZDURCHMESSER (OBEN / UNTEN)
- AXLE STANDARD (REAR / FRONT)
ACHSENSTANDARD (HINTEN / VORNE)
- BOTTOM BRACKET STANDARD
TRETLAGERSTANDARD
- SEAT POST DIAMETER
SÄTTELSTÜTZENDURCHMESSER
- SHOCK HARDWARE (Ø 8 MM)
DÄMPFERBÜCHSENMASSE (Ø 8 MM)
- SHOCK LENGTH
DÄMPFERENBAULÄNGE
- SHOCK TRAVEL
DÄMPFERHUB
- FRONT FORK TRAVEL
FEDERWEG VORNE
- REAR WHEEL TRAVEL
FEDERWEG HINTEN
- STEM LENGTH
VORBAULÄNGE
- HANDLEBAR WIDTH
LENKERBREITE
- CRANK LENGTH
KURBELLÄNGE
- SEAT TUBE BOTTLE MOUNT
FLASCHE SÄTTELROHR
- DOWNTUBE BOTTLE MOUNT
FLASCHE UNTERROHR

STL CSL TTL HTL HTA STA BB WB ST RE SOH ST DT

| | STL | CSL | TTL | HTL | HTA | STA | BB | WB | ST | RE | SOH | | | | | | | | | | | | | | |
|----------------------|-----|-----|-----|-----|-----|-----|------|------|-----|-----|-----|-------|---------|--|------|------------------|-----|----|-----|-----|----|-----|-----|---|------|
| PATH RIOT LTD | | | | | | | | | | | | | | | | | | | | | | | | | |
| S | 417 | 446 | 580 | 90 | 64 | 77 | 38.1 | 1219 | 604 | 440 | 742 | 0 / 0 | 148/110 | | 34,9 | Trunnion / 30x10 | 185 | 55 | 150 | 140 | 40 | 760 | 170 | - | 0,5 |
| M | 441 | 446 | 614 | 110 | 64 | 77 | 38.1 | 1257 | 622 | 470 | 757 | 0 / 0 | 148/110 | | 34,9 | Trunnion / 30x10 | 185 | 55 | 150 | 140 | 40 | 780 | 170 | - | 0,75 |
| L | 465 | 455 | 646 | 140 | 64 | 77 | 33.2 | 1306 | 644 | 497 | 783 | 0 / 0 | 148/110 | | 34,9 | Trunnion / 30x10 | 185 | 55 | 150 | 140 | 40 | 780 | 175 | - | 0,75 |
| XL | 489 | 455 | 680 | 160 | 64 | 77 | 33.2 | 1345 | 662 | 527 | 801 | 0 / 0 | 148/110 | | 34,9 | Trunnion / 30x10 | 185 | 55 | 150 | 140 | 40 | 780 | 175 | - | 0,75 |

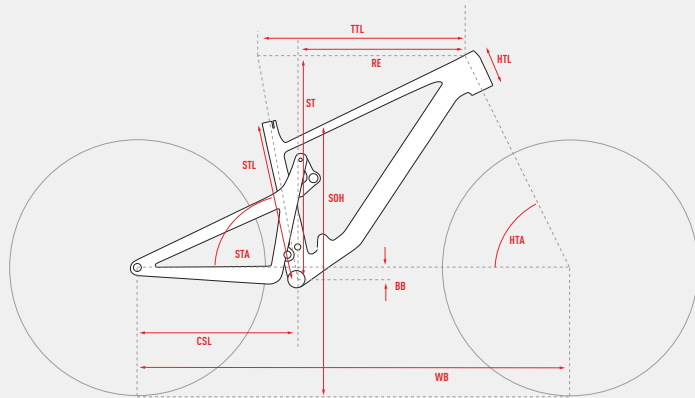

ALL DIMENSIONS IN MM (EXCEPT HTA AND STA IN °)

ALLE MASSE IN MM (AUSNAHME HTA UND STA IN °)

- STL** SEAT TUBE LENGTH
SITZROHRLÄNGE
- CSL** CHAINSTAY LENGTH
KETTENSTREBENLÄNGE
- TTL** TOP TUBE LENGTH
OBERROHRLÄNGE
- HTL** HEAD TUBE LENGTH
STEUERROHRLÄNGE
- HTA** HEAD TUBE ANGLE
STEUERROHRWINKEL
- STA** SEAT TUBE ANGLE
SITZROHRWINKEL
- BB** BOTTOM BRACKET DROP
INNENLAGERABSENKUNG
- WB** WHEELBASE
RADSTAND
- ST** STACK
STACK
- RE** REACH
REACH
- SOH** STANDOVER HEIGHT
ÜBERSTANDSHÖHE
- HEAD SET DIAMETER (UPPER / LOWER)**
STEUERSATZDURCHMESSER (OBEN / UNTEN)
- AXLE STANDARD (REAR / FRONT)**
ACHSENSTANDARD (HINTEN / VORNE)
- BOTTOM BRACKET STANDARD**
TRETLAGERSTANDARD
- SEAT POST DIAMETER**
SÄTTELSTÜTZENDURCHMESSER
- SHOCK HARDWARE (Ø 8 MM)**
DÄMPFERBUCHSENMASSE (Ø 8 MM)
- SHOCK LENGTH**
DÄMPFERENBAULÄNGE
- SHOCK TRAVEL**
DÄMPFERHUB
- FRONT FORK TRAVEL**
FEDERWEG VORNE
- REAR WHEEL TRAVEL**
FEDERWEG HINTEN
- STEM LENGTH**
VORBAULÄNGE
- HANDLEBAR WIDTH**
LENKERBREITE
- CRANK LENGTH**
KURBELLÄNGE
- SEAT TUBE BOTTLE MOUNT**
FLASCHE SÄTTELROHR
- DOWNTUBE BOTTLE MOUNT**
FLASCHE UNTERROHR

STL CSL TTL HTL HTA STA BB WB ST RE SOH

PATH RIOT ADVANCED

| | STL | CSL | TTL | HTL | HTA | STA | BB | WB | ST | RE | SOH | | | | | | | | | | | | | | |
|----|-----|-----|-----|-----|------|------|------|------|-----|-----|-----|-------|---------|------|------------------|-----|----|-----|-----|----|-----|-----|---|------|--|
| S | 417 | 446 | 581 | 90 | 63.5 | 76.5 | 34.2 | 1224 | 607 | 435 | 746 | 0 / 0 | 148/110 | 34,9 | Trunnion / 30x10 | 185 | 55 | 160 | 140 | 40 | 760 | 170 | - | 0,5 | |
| M | 441 | 446 | 615 | 110 | 63.5 | 76.5 | 34.3 | 1263 | 626 | 465 | 762 | 0 / 0 | 148/110 | 34,9 | Trunnion / 30x10 | 185 | 55 | 160 | 140 | 40 | 780 | 170 | - | 0,75 | |
| L | 465 | 455 | 647 | 140 | 63.5 | 76.5 | 29.5 | 1312 | 648 | 492 | 787 | 0 / 0 | 148/110 | 34,9 | Trunnion / 30x10 | 185 | 55 | 160 | 140 | 40 | 780 | 175 | - | 0,75 | |
| XL | 489 | 455 | 681 | 160 | 63.5 | 76.5 | 29.6 | 1360 | 666 | 522 | 805 | 0 / 0 | 148/110 | 34,9 | Trunnion / 30x10 | 185 | 55 | 160 | 140 | 40 | 780 | 175 | - | 0,75 | |

STL CSL TTL HTL HTA STA BB WB ST RE SOH

PATH RIOT FULL PARTY

| | STL | CSL | TTL | HTL | HTA | STA | BB | WB | ST | RE | SOH | | | | | | | | | | | | | | |
|----|-----|-----|-----|-----|------|------|------|------|-----|-----|-----|-------|---------|------|------------------|-----|----|-----|-----|----|-----|-----|---|------|--|
| S | 417 | 446 | 581 | 90 | 63.5 | 76.5 | 34.2 | 1224 | 607 | 435 | 746 | 0 / 0 | 148/110 | 34,9 | Trunnion / 30x10 | 185 | 55 | 160 | 140 | 40 | 760 | 170 | - | 0,5 | |
| M | 441 | 446 | 615 | 110 | 63.5 | 76.5 | 34.3 | 1263 | 626 | 465 | 762 | 0 / 0 | 148/110 | 34,9 | Trunnion / 30x10 | 185 | 55 | 160 | 140 | 40 | 780 | 170 | - | 0,75 | |
| L | 465 | 455 | 647 | 140 | 63.5 | 76.5 | 29.5 | 1312 | 648 | 492 | 787 | 0 / 0 | 148/110 | 34,9 | Trunnion / 30x10 | 185 | 55 | 160 | 140 | 40 | 780 | 175 | - | 0,75 | |
| XL | 489 | 455 | 681 | 160 | 63.5 | 76.5 | 29.6 | 1360 | 666 | 522 | 805 | 0 / 0 | 148/110 | 34,9 | Trunnion / 30x10 | 185 | 55 | 160 | 140 | 40 | 780 | 175 | - | 0,75 | |

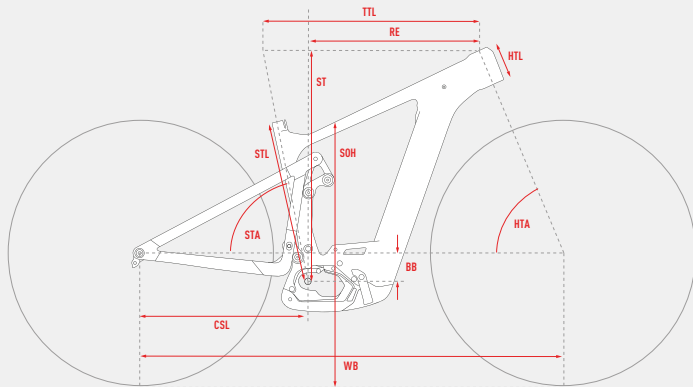

ALL DIMENSIONS IN MM (EXCEPT HTA AND STA IN °)

ALLE MASSE IN MM (AUSNAHME HTA UND STA IN °)

- STL** SEAT TUBE LENGTH
SITZROHRLÄNGE
- CSL** CHAINSTAY LENGTH
KETTENSTREBENLÄNGE
- TTL** TOP TUBE LENGTH
OBERROHRLÄNGE
- HTL** HEAD TUBE LENGTH
STEUERROHRLÄNGE
- HTA** HEAD TUBE ANGLE
STEUERROHRWINKEL
- STA** SEAT TUBE ANGLE
SITZROHRWINKEL
- BB** BOTTOM BRACKET DROP
INNENLAGERABSENKUNG
- WB** WHEELBASE
RADSTAND
- ST** STACK
STACK
- RE** REACH
REACH
- SOH** STANDOVER HEIGHT
ÜBERSTANDSHÖHE
- HEAD SET DIAMETER (UPPER / LOWER)
STEUERSATZDURCHMESSER (OBEN / UNTEN)
- AXLE STANDARD (REAR / FRONT)
ACHSENSTANDARD (HINTEN / VORNE)
- BOTTOM BRACKET STANDARD
TRETLAGERSTANDARD
- SEAT POST DIAMETER
SITTELSTÜTZENDURCHMESSER
- SHOCK HARDWARE (Ø 8 MM)
DÄMPFERBÜCHSENMASSE (Ø 8 MM)
- SHOCK LENGTH
DÄMPFERENBAULÄNGE
- SHOCK TRAVEL
DÄMPFERHUB
- FRONT FORK TRAVEL
FEDERWEG VORNE
- REAR WHEEL TRAVEL
FEDERWEG HINTEN
- STEM LENGTH
VORBAULÄNGE
- HANDLEBAR WIDTH
LENKERBREITE
- CRANK LENGTH
KURBELLÄNGE
- SEAT TUBE BOTTLE MOUNT
FLASCHE SITTELROHR
- DOWNTUBE BOTTLE MOUNT
FLASCHE UNTERROHR

STL CSL TTL HTL HTA STA BB WB ST RE SOH ST DT

E-RIOT AM FULL PARTY

| | STL | CSL | TTL | HTL | HTA | STA | BB | WB | ST | RE | SOH | | | | | | | | | | | | | | ST | | DT |
|----|-----|-----|-----|-----|------|-----|----|------|-----|-----|-----|---------|---------|------|------------------|-----|----|-----|-----|----|-----|-----|---|--------------|----|--|----|
| S | 417 | 435 | 588 | 120 | 65.5 | 76 | 24 | 1197 | 617 | 442 | 746 | 44 / 56 | 148/110 | 34.9 | Trunnion / 30x10 | 205 | 65 | 160 | 160 | 50 | 780 | 165 | - | Fidlock 0,45 | | | |
| M | 441 | 455 | 618 | 100 | 65.5 | 77 | 38 | 1248 | 627 | 468 | 740 | 44 / 56 | 148/110 | 34.9 | Trunnion / 30x10 | 205 | 65 | 160 | 160 | 50 | 780 | 165 | - | Fidlock 0,45 | | | |
| L | 465 | 455 | 648 | 140 | 65.5 | 77 | 38 | 1285 | 663 | 489 | 748 | 44 / 56 | 148/110 | 34.9 | Trunnion / 30x10 | 205 | 65 | 160 | 160 | 50 | 780 | 170 | - | Fidlock 0,6 | | | |
| XL | 489 | 455 | 682 | 160 | 65.5 | 77 | 38 | 1323 | 682 | 519 | 751 | 44 / 56 | 148/110 | 34.9 | Trunnion / 30x10 | 205 | 65 | 160 | 160 | 50 | 780 | 170 | - | Fidlock 0,6 | | | |

STL CSL TTL HTL HTA STA BB WB ST RE SOH ST DT

E-RIOT AM PRO

| | STL | CSL | TTL | HTL | HTA | STA | BB | WB | ST | RE | SOH | | | | | | | | | | | | | | ST | | DT |
|----|-----|-----|-----|-----|------|-----|----|------|-----|-----|-----|---------|---------|------|------------------|-----|----|-----|-----|----|-----|-----|---|--------------|----|--|----|
| S | 417 | 435 | 588 | 120 | 65.5 | 76 | 24 | 1197 | 617 | 442 | 746 | 44 / 56 | 148/110 | 34.9 | Trunnion / 30x10 | 205 | 65 | 160 | 160 | 45 | 760 | 165 | - | Fidlock 0,45 | | | |
| M | 441 | 455 | 618 | 100 | 65.5 | 77 | 38 | 1248 | 627 | 468 | 740 | 44 / 56 | 148/110 | 34.9 | Trunnion / 30x10 | 205 | 65 | 160 | 160 | 45 | 780 | 165 | - | Fidlock 0,45 | | | |
| L | 465 | 455 | 648 | 140 | 65.5 | 77 | 38 | 1285 | 663 | 489 | 748 | 44 / 56 | 148/110 | 34.9 | Trunnion / 30x10 | 205 | 65 | 160 | 160 | 45 | 780 | 170 | - | Fidlock 0,6 | | | |
| XL | 489 | 455 | 682 | 160 | 65.5 | 77 | 38 | 1323 | 682 | 519 | 751 | 44 / 56 | 148/110 | 34.9 | Trunnion / 30x10 | 205 | 65 | 160 | 160 | 45 | 780 | 170 | - | Fidlock 0,6 | | | |

STL CSL TTL HTL HTA STA BB WB ST RE SOH ST DT

E-RIOT AM ADVANCED

| | STL | CSL | TTL | HTL | HTA | STA | BB | WB | ST | RE | SOH | | | | | | | | | | | | | | ST | | DT |
|----|-----|-----|-----|-----|------|-----|----|------|-----|-----|-----|---------|---------|------|------------------|-----|----|-----|-----|----|-----|-----|---|--------------|----|-----|----|
| S | 417 | 435 | 588 | 120 | 65.5 | 76 | 24 | 1197 | 617 | 442 | 746 | 44 / 56 | 148/110 | 34.9 | Trunnion / 30x10 | 205 | 65 | 160 | 160 | 45 | 760 | 165 | - | Fidlock 0,45 | | | |
| M | 441 | 455 | 618 | 100 | 65.5 | 77 | 38 | 1248 | 627 | 468 | 740 | 44 / 56 | 148/110 | 34.9 | Trunnion / 30x10 | 205 | 65 | 160 | 160 | 45 | 780 | 165 | - | Fidlock 0,45 | | | |
| L | 465 | 455 | 648 | 140 | 65.5 | 77 | 38 | 1285 | 663 | 489 | 748 | 44 / 56 | 148/110 | 34.9 | Trunnion / 30x10 | 205 | 65 | 160 | 160 | 45 | 780 | 170 | - | Fidlock 0,6 | | | |
| XL | 489 | 455 | 682 | 160 | 65.5 | 77 | 38 | 1323 | 682 | 519 | 751 | 44 / 56 | 148/110 | 34.9 | Trunnion / 30x10 | 205 | 65 | 160 | 160 | 45 | 780 | 170 | - | Fidlock 0,6 | | 0,5 | |

ERIOR TRAIL

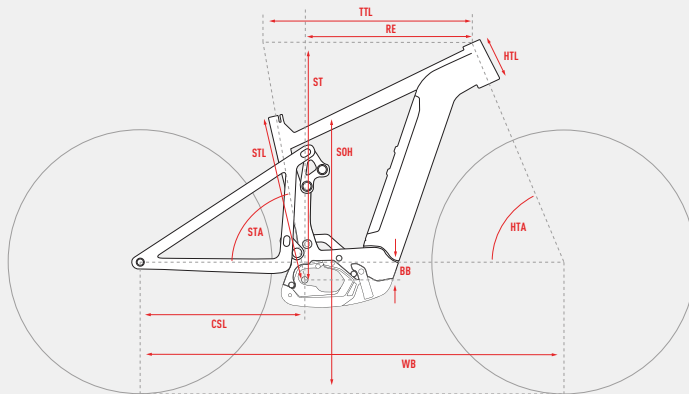

ALL DIMENSIONS IN MM (EXCEPT HTA AND STA IN °)

ALLE MASSE IN MM (AUSNAHME HTA UND STA IN °)

- STL** SEAT TUBE LENGTH
SITZROHRLÄNGE
- CSL** CHAINSTAY LENGTH
KETTENSTREBELÄNGE
- TTL** TOP TUBE LENGTH
OBERROHRLÄNGE
- HTL** HEAD TUBE LENGTH
STEUERROHRLÄNGE
- HTA** HEAD TUBE ANGLE
STEUERROHRWINKEL
- STA** SEAT TUBE ANGLE
SITZROHRWINKEL
- BB** BOTTOM BRACKET DROP
INNENLAGERABSINKUNG
- WB** WHEELBASE
RADSTAND
- ST** STACK
STACK
- RE** REACH
REACH
- SOH** STANDOVER HEIGHT
ÜBERSTANDSHÖHE
- HEAD SET DIAMETER (UPPER / LOWER)
STEUERSATZDURCHMESSER (OBEN / UNTEN)
- AXLE STANDARD (REAR / FRONT)
ACHSENSTANDARD (HINTEN / VORNE)
- BOTTOM BRACKET STANDARD
TRETLAGERSTANDARD
- SEAT POST DIAMETER
SÄTTELSTÜTZENDURCHMESSER
- SHOCK HARDWARE (Ø 8 MM)
DAMPFERBUCHSENMASSE (Ø 8 MM)
- SHOCK LENGTH
DÄMPFEREINBAULÄNGE
- SHOCK TRAVEL
DÄMPFERHÜB
- FRONT FORK TRAVEL
FEDERWEG VORNE
- REAR WHEEL TRAVEL
FEDERWEG HINTEN
- STEM LENGTH
VORBAULÄNGE
- HANDLEBAR WIDTH
LENKERBREITE
- CRANK LENGTH
KURBELLENGE
- SEAT TUBE BOTTLE MOUNT
FLASCHE SÄTTELROHR
- DOWNTUBE BOTTLE MOUNT
FLASCHE UNTERROHR

STL CSL TTL HTL HTA STA BB WB ST RE SOH

E-RIOT TRAIL ADVANCED

| | STL | CSL | TTL | HTL | HTA | STA | BB | WB | ST | RE | SOH | | | | | | | | | | | | | | |
|----|-----|-----|-----|-----|------|-----|----|------|-----|-----|-----|---------|---------|------|------------------|-----|----|-----|-----|----|-----|-----|---|--------------|--|
| S | 417 | 435 | 588 | 120 | 65.5 | 76 | 24 | 1197 | 617 | 442 | 746 | 44 / 56 | 148/110 | 34.9 | Trunnion / 30x10 | 185 | 55 | 150 | 140 | 45 | 760 | 165 | - | Fidlock 0,45 | |
| M | 441 | 455 | 618 | 100 | 65.5 | 77 | 38 | 1248 | 627 | 468 | 740 | 44 / 56 | 148/110 | 34.9 | Trunnion / 30x10 | 185 | 55 | 150 | 140 | 45 | 780 | 165 | - | Fidlock 0,45 | |
| L | 465 | 455 | 648 | 140 | 65.5 | 77 | 38 | 1285 | 663 | 489 | 748 | 44 / 56 | 148/110 | 34.9 | Trunnion / 30x10 | 185 | 55 | 150 | 140 | 45 | 780 | 170 | - | Fidlock 0,6 | |
| XL | 489 | 455 | 682 | 160 | 65.5 | 77 | 38 | 1323 | 682 | 519 | 751 | 44 / 56 | 148/110 | 34.9 | Trunnion / 30x10 | 185 | 55 | 150 | 140 | 45 | 780 | 170 | - | Fidlock 0,6 | |

STL CSL TTL HTL HTA STA BB WB ST RE SOH

E-RIOT TRAIL ESSENTIAL

| | STL | CSL | TTL | HTL | HTA | STA | BB | WB | ST | RE | SOH | | | | | | | | | | | | | | |
|----|-----|-----|-----|-----|------|-----|----|------|-----|-----|-----|---------|---------|------|------------------|-----|----|-----|-----|----|-----|-----|---|--------------|--|
| S | 417 | 435 | 588 | 120 | 65.5 | 76 | 24 | 1197 | 617 | 442 | 746 | 44 / 56 | 148/110 | 34.9 | Trunnion / 30x10 | 185 | 55 | 150 | 140 | 45 | 760 | 165 | - | Fidlock 0,45 | |
| M | 441 | 455 | 618 | 100 | 65.5 | 77 | 38 | 1248 | 627 | 468 | 740 | 44 / 56 | 148/110 | 34.9 | Trunnion / 30x10 | 185 | 55 | 150 | 140 | 45 | 780 | 165 | - | Fidlock 0,45 | |
| L | 465 | 455 | 648 | 140 | 65.5 | 77 | 38 | 1285 | 663 | 489 | 748 | 44 / 56 | 148/110 | 34.9 | Trunnion / 30x10 | 185 | 55 | 150 | 140 | 45 | 780 | 170 | - | Fidlock 0,6 | |
| XL | 489 | 455 | 682 | 160 | 65.5 | 77 | 38 | 1323 | 682 | 519 | 751 | 44 / 56 | 148/110 | 34.9 | Trunnion / 30x10 | 185 | 55 | 150 | 140 | 45 | 780 | 170 | - | Fidlock 0,6 | |



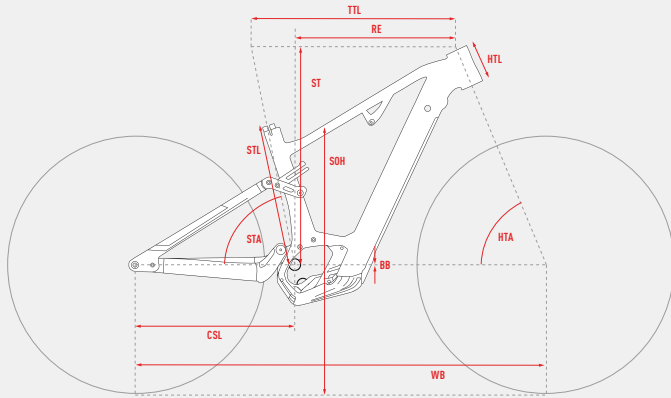





E/ASX 160



ALL DIMENSIONS IN MM (EXCEPT HTA AND STA IN °)

ALLE MASSE IN MM (AUSNAHME HTA UND STA IN °)

- STL** SEAT TUBE LENGTH
SITZROHRLÄNGE
- CSL** CHAINSTAY LENGTH
KETTENSTREBENLÄNGE
- TTL** TOP TUBE LENGTH
OBERROHRLÄNGE
- HTL** HEAD TUBE LENGTH
STEUERROHRLÄNGE
- HTA** HEAD TUBE ANGLE
STEUERROHRWINKEL
- STA** SEAT TUBE ANGLE
SITZROHRWINKEL
- BB** BOTTOM BRACKET DROP
INNENLAGERABSENKUNG
- WB** WHEELBASE
RADSTAND
- ST** STACK
STACK
- RE** REACH
REACH
- SOH** STANDOVER HEIGHT
ÜBERSTANDSHÖHE
-  HEAD SET DIAMETER (UPPER / LOWER)
STEUERSATZDURCHMESSER (OBEN / UNTEN)
-  AXLE STANDARD (REAR / FRONT)
ACHSENSTANDARD (HINTEN / VORNE)
-  BOTTOM BRACKET STANDARD
TRETLAGERSTANDARD
-  SEAT POST DIAMETER
SITZELSTÜTZENDURCHMESSER
-  SHOCK HARDWARE (Ø 8 MM)
DÄMPFERBUCHSENMASSE (Ø 8 MM)
-  SHOCK LENGTH
DÄMPFERENBAULÄNGE
-  SHOCK TRAVEL
DÄMPFERHUB
-  FRONT FORK TRAVEL
FEDERWEG VORNE
-  REAR WHEEL TRAVEL
FEDERWEG HINTEN
-  STEM LENGTH
VORBAULÄNGE
-  HANDLEBAR WIDTH
LENKERBREITE
-  CRANK LENGTH
KURBELLÄNGE
-  SEAT TUBE BOTTLE MOUNT
FLASCHE SÄTTELROHR
-  DOWNTUBE BOTTLE MOUNT
FLASCHE UNTERROHR

STL CSL TTL HTL HTA STA BB WB ST RE SOH              

E-ASX 160 UNIVERSAL

| | | | | | | | | | | | | | | | | | | | | | | | | |
|----|-----|-----|-----|-----|------|------|-----|------|-----|-----|-----|-------|---------|------|-------------|-----|----|-----|-----|----|-----|-----|---|------|
| S | 390 | 460 | 587 | 100 | 64.5 | 76.5 | -30 | 1230 | 631 | 435 | 735 | 0 / 0 | 148/110 | 31,6 | 25x8 / 15x8 | 230 | 60 | 160 | 160 | 45 | 760 | 165 | - | 0,5 |
| M | 430 | 460 | 609 | 110 | 65 | 76.5 | -30 | 1248 | 641 | 455 | 749 | 0 / 0 | 148/110 | 31,6 | 25x8 / 15x8 | 230 | 60 | 160 | 160 | 45 | 780 | 165 | - | 0,5 |
| L | 470 | 460 | 633 | 130 | 65 | 76.5 | -30 | 1276 | 659 | 475 | 748 | 0 / 0 | 148/110 | 31,6 | 25x8 / 15x8 | 230 | 60 | 160 | 160 | 45 | 780 | 170 | - | 0,5 |
| XL | 510 | 460 | 663 | 150 | 65 | 76.5 | -30 | 1310 | 678 | 500 | 757 | 0 / 0 | 148/110 | 31,6 | 25x8 / 15x8 | 230 | 60 | 160 | 160 | 45 | 780 | 170 | - | 0,75 |

STL CSL TTL HTL HTA STA BB WB ST RE SOH              

E-ASX 160 ESSENTIAL

| | | | | | | | | | | | | | | | | | | | | | | | | |
|----|-----|-----|-----|-----|------|------|-----|------|-----|-----|-----|-------|---------|------|-------------|-----|----|-----|-----|----|-----|-----|---|------|
| S | 390 | 460 | 587 | 100 | 64.5 | 76.5 | -30 | 1230 | 631 | 435 | 735 | 0 / 0 | 148/110 | 31,6 | 25x8 / 15x8 | 230 | 60 | 160 | 160 | 45 | 760 | 165 | - | 0,5 |
| M | 430 | 460 | 609 | 110 | 65 | 76.5 | -30 | 1248 | 641 | 455 | 749 | 0 / 0 | 148/110 | 31,6 | 25x8 / 15x8 | 230 | 60 | 160 | 160 | 45 | 800 | 165 | - | 0,5 |
| L | 470 | 460 | 633 | 130 | 65 | 76.5 | -30 | 1276 | 659 | 475 | 748 | 0 / 0 | 148/110 | 31,6 | 25x8 / 15x8 | 230 | 60 | 160 | 160 | 45 | 800 | 170 | - | 0,5 |
| XL | 510 | 460 | 663 | 150 | 65 | 76.5 | -30 | 1310 | 678 | 500 | 757 | 0 / 0 | 148/110 | 31,6 | 25x8 / 15x8 | 230 | 60 | 160 | 160 | 45 | 800 | 170 | - | 0,75 |

E/SX 130

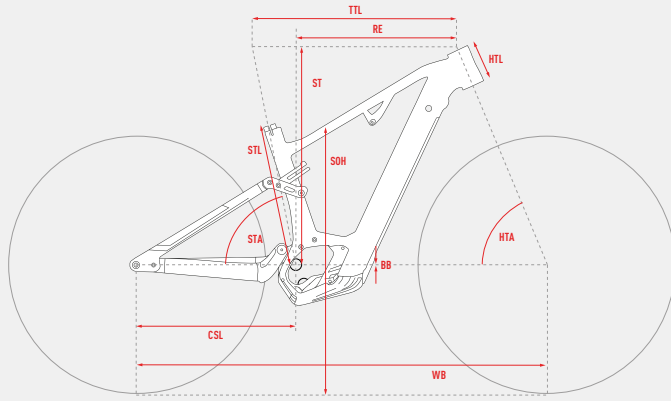

ALL DIMENSIONS IN MM (EXCEPT HTA AND STA IN °)

ALLE MASSE IN MM (AUSNAHME HTA UND STA IN °)

- STL** SEAT TUBE LENGTH
SITZROHRLÄNGE
- CSL** CHAINSTAY LENGTH
KETTENSTREBELÄNGE
- TTL** TOP TUBE LENGTH
OBERROHRLÄNGE
- HTL** HEAD TUBE LENGTH
STEUERROHRLÄNGE
- HTA** HEAD TUBE ANGLE
STEUERROHRWINKEL
- STA** SEAT TUBE ANGLE
SITZROHRWINKEL
- BB** BOTTOM BRACKET DROP
INNENLAGERABSINKUNG
- WB** WHEELBASE
RADSTAND
- ST** STACK
STACK
- RE** REACH
REACH
- SOH** STANDOVER HEIGHT
ÜBERSTANDSHÖHE
- HEAD SET DIAMETER (UPPER / LOWER)**
STEUERSATZDURCHMESSER (OBEN / UNTEN)
- AXLE STANDARD (REAR / FRONT)**
ACHSENSTANDARD (HINTEN / VORNE)
- BOTTOM BRACKET STANDARD**
TRETLAGERSTANDARD
- SEAT POST DIAMETER**
SÄTTELSTÜTZENDURCHMESSER
- SHOCK HARDWARE (Ø 8 MM)**
DAMPFERBUCHSENMASSE (Ø 8 MM)
- SHOCK LENGTH**
DÄMPFEREINBAULÄNGE
- SHOCK TRAVEL**
DÄMPFERHÜB
- FRONT FORK TRAVEL**
FEDERWEG VORNE
- REAR WHEEL TRAVEL**
FEDERWEG HINTEN
- STEM LENGTH**
VORBAULÄNGE
- HANDLEBAR WIDTH**
LENKERBREITE
- CRANK LENGTH**
KURBELLENGE
- SEAT TUBE BOTTLE MOUNT**
FLASCHE SÄTTELROHR
- DOWNTUBE BOTTLE MOUNT**
FLASCHE UNTERROHR

STL CSL TTL HTL HTA STA BB WB ST RE SOH

E-ASX 130 UNIVERSAL

| | | | | | | | | | | | | | | | | | | | | | | | | |
|----|-----|-----|-----|-----|------|----|-----|------|-----|-----|-----|-------|---------|------|-------------|-----|----|-----|-----|----|-----|-----|---|------|
| S | 390 | 460 | 588 | 110 | 65.5 | 76 | -30 | 1216 | 611 | 436 | 738 | 0 / 0 | 148/110 | 31,6 | 25x8 / 15x8 | 230 | 50 | 130 | 130 | 45 | 760 | 165 | - | 0,5 |
| M | 430 | 460 | 610 | 120 | 66 | 76 | -30 | 1233 | 621 | 455 | 756 | 0 / 0 | 148/110 | 31,6 | 25x8 / 15x8 | 230 | 50 | 130 | 130 | 45 | 780 | 165 | - | 0,5 |
| L | 470 | 460 | 634 | 140 | 66 | 76 | -30 | 1261 | 640 | 475 | 753 | 0 / 0 | 148/110 | 31,6 | 25x8 / 15x8 | 230 | 50 | 130 | 130 | 45 | 780 | 170 | - | 0,75 |
| XL | 510 | 460 | 664 | 160 | 66 | 76 | -30 | 1294 | 658 | 500 | 759 | 0 / 0 | 148/110 | 31,6 | 25x8 / 15x8 | 230 | 50 | 130 | 130 | 45 | 780 | 170 | - | 0,75 |

STL CSL TTL HTL HTA STA BB WB ST RE SOH

E-ASX 130 ESSENTIAL

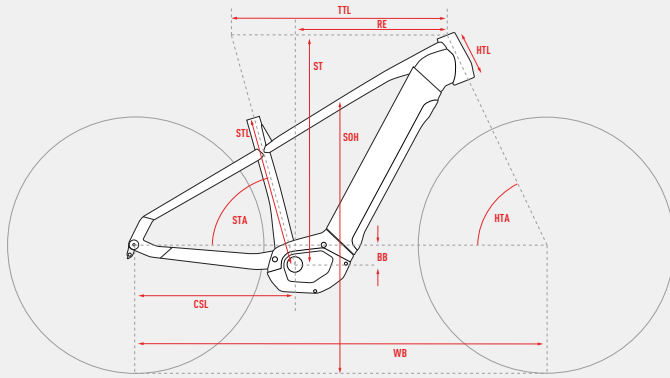

| | | | | | | | | | | | | | | | | | | | | | | | | |
|----|-----|-----|-----|-----|------|----|-----|------|-----|-----|-----|-------|---------|------|-------------|-----|----|-----|-----|----|-----|-----|---|------|
| S | 390 | 460 | 588 | 110 | 65.5 | 76 | -30 | 1216 | 611 | 436 | 738 | 0 / 0 | 148/110 | 31,6 | 25x8 / 15x8 | 230 | 50 | 130 | 130 | 45 | 760 | 165 | - | 0,5 |
| M | 430 | 460 | 610 | 120 | 66 | 76 | -30 | 1233 | 621 | 455 | 756 | 0 / 0 | 148/110 | 31,6 | 25x8 / 15x8 | 230 | 50 | 130 | 130 | 45 | 780 | 165 | - | 0,5 |
| L | 470 | 460 | 634 | 140 | 66 | 76 | -30 | 1261 | 640 | 475 | 753 | 0 / 0 | 148/110 | 31,6 | 25x8 / 15x8 | 230 | 50 | 130 | 130 | 45 | 780 | 170 | - | 0,75 |
| XL | 510 | 460 | 664 | 160 | 66 | 76 | -30 | 1294 | 658 | 500 | 759 | 0 / 0 | 148/110 | 31,6 | 25x8 / 15x8 | 230 | 50 | 130 | 130 | 45 | 780 | 170 | - | 0,75 |

















ALL DIMENSIONS IN MM (EXCEPT HTA AND STA IN °)

ALLE MASSE IN MM (AUSNAHME HTA UND STA IN °)

- STL** SEAT TUBE LENGTH
SITZROHRLÄNGE
- CSL** CHAINSTAY LENGTH
KETTENSTREBENLÄNGE
- TTL** TOP TUBE LENGTH
OBERROHRLÄNGE
- HTL** HEAD TUBE LENGTH
STEUERROHRLÄNGE
- HTA** HEAD TUBE ANGLE
STEUERROHRWINKEL
- STA** SEAT TUBE ANGLE
SITZROHRWINKEL
- BB** BOTTOM BRACKET DROP
INNENLAGERABSENKUNG
- WB** WHEELBASE
RADSTAND
- ST** STACK
STACK
- RE** REACH
REACH
- SOH** STANDOVER HEIGHT
ÜBERSTANDSHÖHE
-  HEAD SET DIAMETER (UPPER / LOWER)
STEUERSATZDURCHMESSER (OBEN / UNTEN)

-  AXLE STANDARD (REAR / FRONT)
ACHSENSTANDARD (HINTEN / VORNE)
-  BOTTOM BRACKET STANDARD
TRETLAGERSTANDARD
-  SEAT POST DIAMETER
SÄTTELSTÜTZENDURCHMESSER
-  SHOCK HARDWARE (Ø 8 MM)
DÄMPFERBUCHSENMASSE (Ø 8 MM)
-  SHOCK LENGTH
DÄMPFERENBAULÄNGE
-  SHOCK TRAVEL
DÄMPFERHUB
-  FRONT FORK TRAVEL
FEDERWEG VORNE
-  REAR WHEEL TRAVEL
FEDERWEG HINTEN
-  STEM LENGTH
VORBAULÄNGE
-  HANDLEBAR WIDTH
LENKERBREITE
-  CRANK LENGTH
KURBELLÄNGE
-  SEAT TUBE BOTTLE MOUNT
FLASCHE SÄTTELROHR
-  DOWNTUBE BOTTLE MOUNT
FLASCHE UNTERROHR

| | STL | CSL | TTL | HTL | HTA | STA | BB | WB | ST | RE | SOH |  |  |  |  |  |  |  |  |  |  |  |  |  |  | | |
|-------------------|-----|-----|-----|-----|-----|-----|-----|------|-----|-----|-----|---|---|---|---|---|---|---|---|---|---|---|---|---|---|--|--|
| E-TERU PRO | | | | | | | | | | | | | | | | | | | | | | | | | | | |
| XS | 380 | 465 | 605 | 140 | 68 | 74 | -65 | 1164 | 661 | 415 | 750 | 0 / 0 | 148/110 | 34,9 | - / - | 0 | 0 | 120 | 0 | 45 | 720 | 165 | - | 0,75 | | | |
| S | 400 | 465 | 610 | 140 | 68 | 74 | -60 | 1171 | 656 | 422 | 758 | 0 / 0 | 148/110 | 34,9 | - / - | 0 | 0 | 120 | 0 | 45 | 720 | 165 | - | 0,75 | | | |
| M | 450 | 475 | 625 | 140 | 67 | 74 | -65 | 1216 | 674 | 432 | 764 | 0 / 0 | 148/110 | 34,9 | - / - | 0 | 0 | 120 | 0 | 45 | 740 | 165 | - | 0,75 | | | |
| L | 500 | 475 | 648 | 155 | 67 | 74 | -65 | 1241 | 688 | 451 | 782 | 0 / 0 | 148/110 | 34,9 | - / - | 0 | 0 | 120 | 0 | 45 | 740 | 170 | - | 0,75 | | | |
| XL | 550 | 475 | 670 | 170 | 67 | 74 | -65 | 1265 | 701 | 469 | 814 | 0 / 0 | 148/110 | 34,9 | - / - | 0 | 0 | 120 | 0 | 45 | 740 | 170 | - | 0,75 | | | |

| | STL | CSL | TTL | HTL | HTA | STA | BB | WB | ST | RE | SOH |  |  |  |  |  |  |  |  |  |  |  |  |  |  | | |
|------------------------|-----|-----|-----|-----|-----|-----|-----|------|-----|-----|-----|---|---|---|---|---|---|---|---|---|---|---|---|---|---|--|--|
| E-TERU ADVANCED | | | | | | | | | | | | | | | | | | | | | | | | | | | |
| S | 400 | 465 | 610 | 140 | 68 | 74 | -60 | 1171 | 656 | 422 | 758 | 0 / 0 | 148/110 | 34,9 | - / - | 0 | 0 | 120 | 0 | 45 | 720 | 165 | - | 0,75 | | | |
| M | 450 | 475 | 625 | 140 | 67 | 74 | -65 | 1216 | 674 | 432 | 764 | 0 / 0 | 148/110 | 34,9 | - / - | 0 | 0 | 120 | 0 | 45 | 740 | 165 | - | 0,75 | | | |
| L | 500 | 475 | 648 | 155 | 67 | 74 | -65 | 1241 | 688 | 451 | 782 | 0 / 0 | 148/110 | 34,9 | - / - | 0 | 0 | 120 | 0 | 45 | 740 | 170 | - | 0,75 | | | |
| XL | 550 | 475 | 670 | 170 | 67 | 74 | -65 | 1265 | 701 | 469 | 814 | 0 / 0 | 148/110 | 34,9 | - / - | 0 | 0 | 120 | 0 | 45 | 740 | 170 | - | 0,75 | | | |



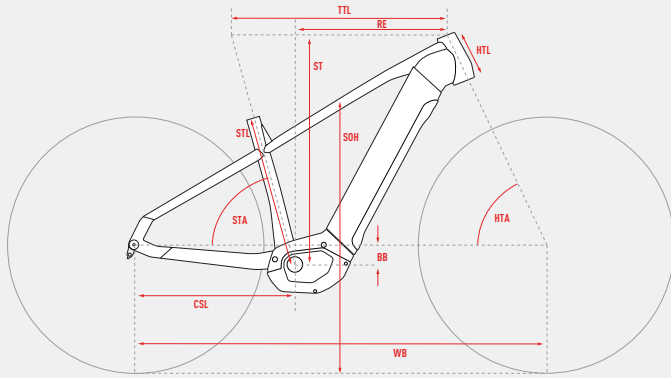











| | STL | CSL | TTL | HTL | HTA | STA | BB | WB | ST | RE | SOH |  |  |  |  |  |  |  |  |  |  |  |  |  |  | | |
|-------------------------|-----|-----|-----|-----|-----|-----|-----|------|-----|-----|-----|---|---|---|---|---|---|---|---|---|---|---|---|---|---|--|--|
| E-TERU UNIVERSAL | | | | | | | | | | | | | | | | | | | | | | | | | | | |
| XS | 380 | 465 | 605 | 140 | 68 | 74 | -65 | 1164 | 661 | 415 | 750 | 0 / 0 | 148/110 | 34,9 | - / - | 0 | 0 | 120 | 0 | 45 | 720 | 165 | - | 0,75 | | | |
| S | 400 | 465 | 610 | 140 | 68 | 74 | -60 | 1171 | 656 | 422 | 758 | 0 / 0 | 148/110 | 34,9 | - / - | 0 | 0 | 120 | 0 | 45 | 720 | 165 | - | 0,75 | | | |
| M | 450 | 465 | 620 | 140 | 68 | 74 | -60 | 1181 | 656 | 432 | 764 | 0 / 0 | 148/110 | 34,9 | - / - | 0 | 0 | 120 | 0 | 45 | 740 | 165 | - | 0,75 | | | |
| L | 500 | 465 | 635 | 155 | 68 | 74 | -60 | 1198 | 670 | 443 | 782 | 0 / 0 | 148/110 | 34,9 | - / - | 0 | 0 | 120 | 0 | 45 | 740 | 170 | - | 0,75 | | | |
| XL | 550 | 465 | 658 | 170 | 68 | 74 | -60 | 1223 | 684 | 462 | 814 | 0 / 0 | 148/110 | 34,9 | - / - | 0 | 0 | 120 | 0 | 45 | 740 | 170 | - | 0,75 | | | |



ALL DIMENSIONS IN MM (EXCEPT HTA AND STA IN °)















ALLE MASSE IN MM (AUSNAHME HTA UND STA IN °)

- STL** SEAT TUBE LENGTH
SITZROHRLÄNGE
- CSL** CHAINSTAY LENGTH
KETTENSTREBENLÄNGE
- TTL** TOP TUBE LENGTH
OBERROHRLÄNGE
- HTL** HEAD TUBE LENGTH
STEUERROHRLÄNGE
- HTA** HEAD TUBE ANGLE
STEUERROHRWINKEL
- STA** SEAT TUBE ANGLE
SITZROHRWINKEL
- BB** BOTTOM BRACKET DROP
INNENLAGERABSENKUNG
- WB** WHEELBASE
RADSTAND
- ST** STACK
STACK
- RE** REACH
REACH
- SOH** STANDOVER HEIGHT
ÜBERSTANDSHÖHE
-  HEAD SET DIAMETER (UPPER / LOWER)
STEUERSATZDURCHMESSER (OBEN / UNTEN)
-  AXLE STANDARD (REAR / FRONT)
ACHSENSTANDARD (HINTEN / VORNE)
-  BOTTOM BRACKET STANDARD
TRETLAGERSTANDARD
-  SEAT POST DIAMETER
SÄTTELSTÜTZENDURCHMESSER
-  SHOCK HARDWARE (Ø 8 MM)
DÄMPFERBUCHSENMASSE (Ø 8 MM)
-  SHOCK LENGTH
DÄMPFEREINBAULÄNGE
-  SHOCK TRAVEL
DÄMPFERHUB
-  FRONT FORK TRAVEL
FEDERWEG VORNE
-  REAR WHEEL TRAVEL
FEDERWEG HINTEN
-  STEM LENGTH
VORBAULÄNGE
-  HANDLEBAR WIDTH
LENKERBREITE
-  CRANK LENGTH
KURBELLÄNGE
-  SEAT TUBE BOTTLE MOUNT
FLASCHE SÄTTELROHR
-  DOWNTUBE BOTTLE MOUNT
FLASCHE UNTERROHR

STL CSL TTL HTL HTA STA BB WB ST RE SOH              











E-TERU PRO EQ

| | | | | | | | | | | | | | | | | | | | | | | | | |
|----|-----|-----|-----|-----|----|----|-----|------|-----|-----|-----|-------|---------|------|-------|---|---|-----|---|----|-----|-----|---|------|
| XS | 380 | 465 | 605 | 140 | 68 | 74 | -65 | 1164 | 661 | 415 | 750 | 0 / 0 | 148/110 | 34,9 | - / - | 0 | 0 | 100 | 0 | 80 | 720 | 165 | - | 0,75 |
| S | 400 | 465 | 610 | 140 | 68 | 74 | -60 | 1171 | 656 | 422 | 758 | 0 / 0 | 148/110 | 34,9 | - / - | 0 | 0 | 100 | 0 | 80 | 740 | 165 | - | 0,75 |
| M | 450 | 465 | 620 | 140 | 68 | 74 | -60 | 1181 | 656 | 432 | 755 | 0 / 0 | 148/110 | 34,9 | - / - | 0 | 0 | 100 | 0 | 80 | 740 | 165 | - | 0,75 |
| L | 500 | 465 | 635 | 155 | 68 | 74 | -60 | 1198 | 670 | 443 | 755 | 0 / 0 | 148/110 | 34,9 | - / - | 0 | 0 | 100 | 0 | 80 | 740 | 170 | - | 0,75 |
| XL | 550 | 465 | 658 | 170 | 68 | 74 | -60 | 1223 | 684 | 462 | 790 | 0 / 0 | 148/110 | 34,9 | - / - | 0 | 0 | 100 | 0 | 80 | 740 | 170 | - | 0,75 |

STL CSL TTL HTL HTA STA BB WB ST RE SOH              

E-TERU ADVANCED EQ

| | | | | | | | | | | | | | | | | | | | | | | | | |
|-----|-----|-----|-----|-----|----|----|-----|------|-----|-----|-----|-------|---------|------|-------|---|---|-----|---|----|-----|-----|---|------|
| S | 400 | 465 | 600 | 140 | 68 | 74 | -60 | 1162 | 653 | 413 | 758 | 0 / 0 | 148/110 | 34,9 | - / - | 0 | 0 | 100 | 0 | 80 | 720 | 165 | - | 0,75 |
| M | 450 | 465 | 610 | 140 | 68 | 74 | -60 | 1172 | 653 | 423 | 755 | 0 / 0 | 148/110 | 34,9 | - / - | 0 | 0 | 100 | 0 | 80 | 740 | 165 | - | 0,75 |
| L | 500 | 465 | 634 | 155 | 68 | 74 | -60 | 1198 | 667 | 443 | 755 | 0 / 0 | 148/110 | 34,9 | - / - | 0 | 0 | 100 | 0 | 80 | 740 | 170 | - | 0,75 |
| XL | 550 | 465 | 658 | 170 | 68 | 74 | -60 | 1223 | 681 | 463 | 790 | 0 / 0 | 148/110 | 34,9 | - / - | 0 | 0 | 100 | 0 | 80 | 740 | 170 | - | 0,75 |
| XXL | 600 | 465 | 680 | 180 | 68 | 74 | -60 | 1246 | 690 | 482 | 0 | 0 / 0 | 148/110 | 34,9 | - / - | 0 | 0 | 100 | 0 | 80 | 740 | 170 | - | 0,75 |

STL CSL TTL HTL HTA STA BB WB ST RE SOH              

E-TERU UNIVERSAL EQ

| | | | | | | | | | | | | | | | | | | | | | | | | |
|----|-----|-----|-----|-----|----|----|-----|------|-----|-----|-----|-------|---------|------|-------|---|---|-----|---|----|-----|-----|---|------|
| XS | 380 | 465 | 605 | 140 | 68 | 74 | -65 | 1164 | 661 | 415 | 750 | 0 / 0 | 148/110 | 34,9 | - / - | 0 | 0 | 100 | 0 | 80 | 720 | 165 | - | 0,75 |
| S | 400 | 465 | 610 | 140 | 68 | 74 | -60 | 1171 | 656 | 422 | 758 | 0 / 0 | 148/110 | 34,9 | - / - | 0 | 0 | 100 | 0 | 80 | 720 | 165 | - | 0,75 |
| M | 450 | 465 | 620 | 140 | 68 | 74 | -60 | 1181 | 656 | 432 | 755 | 0 / 0 | 148/110 | 34,9 | - / - | 0 | 0 | 100 | 0 | 80 | 740 | 165 | - | 0,75 |
| L | 500 | 465 | 635 | 155 | 68 | 74 | -60 | 1198 | 670 | 443 | 755 | 0 / 0 | 148/110 | 34,9 | - / - | 0 | 0 | 100 | 0 | 80 | 740 | 170 | - | 0,75 |
| XL | 550 | 465 | 658 | 170 | 68 | 74 | -60 | 1223 | 684 | 462 | 790 | 0 / 0 | 148/110 | 34,9 | - / - | 0 | 0 | 100 | 0 | 80 | 740 | 170 | - | 0,75 |

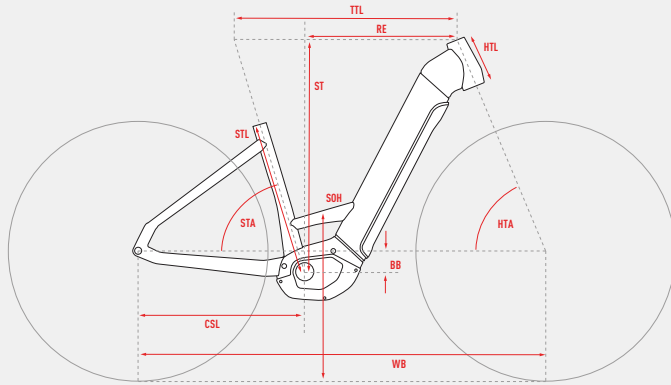















ALL DIMENSIONS IN MM (EXCEPT HTA AND STA IN °)

ALLE MASSE IN MM (AUSNAHME HTA UND STA IN °)















- STL** SEAT TUBE LENGTH
SITZROHRLÄNGE
- CSL** CHAINSTAY LENGTH
KETTENSTREBELÄNGE
- TTL** TOP TUBE LENGTH
OBERROHRLÄNGE
- HTL** HEAD TUBE LENGTH
STEUERROHRLÄNGE
- HTA** HEAD TUBE ANGLE
STEUERROHRWINKEL
- STA** SEAT TUBE ANGLE
SITZROHRWINKEL
- BB** BOTTOM BRACKET DROP
INNENLAGERABSINKUNG
- WB** WHEELBASE
RADSTAND
- ST** STACK
STACK
- RE** REACH
REACH
- SOH** STANDOVER HEIGHT
ÜBERSTANDSHÖHE
-  **HEAD SET DIAMETER (UPPER / LOWER)**
STEUERSATZDURCHMESSER (OBEN / UNTEN)

-  **AXLE STANDARD (REAR / FRONT)**
ACHSENSTANDARD (HINTEN / VORNE)
-  **BOTTOM BRACKET STANDARD**
TRETLAGERSTANDARD
-  **SEAT POST DIAMETER**
SÄTTELSTÜTZENDURCHMESSER
-  **SHOCK HARDWARE (Ø 8 MM)**
DAMPFERBUCHSENMASSE (Ø 8 MM)
-  **SHOCK LENGTH**
DAMPFEREINBAULÄNGE
-  **SHOCK TRAVEL**
DAMPFERHÜB
-  **FRONT FORK TRAVEL**
FEDERWEG VORNE
-  **REAR WHEEL TRAVEL**
FEDERWEG HINTEN
-  **STEM LENGTH**
VORBAULÄNGE
-  **HANDLEBAR WIDTH**
LENKERBREITE
-  **CRANK LENGTH**
KURBELLÄNGE
-  **SEAT TUBE BOTTLE MOUNT**
FLASCHE SÄTTELROHR
-  **DOWNTUBE BOTTLE MOUNT**
FLASCHE UNTERROHR

| | STL | CSL | TTL | HTL | HTA | STA | BB | WB | ST | RE | SOH |  |  |  |  |  |  |  |  |  |  |  |  |  |  |
|--|-----|-----|-----|-----|-----|-----|----|----|----|----|-----|---|---|---|---|---|---|---|---|---|---|---|---|---|---|
|--|-----|-----|-----|-----|-----|-----|----|----|----|----|-----|---|---|---|---|---|---|---|---|---|---|---|---|---|---|













E-TERU PRO EQ LOW

| | | | | | | | | | | | | | | | | | | | | | | | | |
|---|-----|-----|-----|-----|----|----|-----|------|-----|-----|-----|-------|---------|------|-------|---|---|-----|---|----|-----|-----|---|------|
| S | 380 | 475 | 610 | 150 | 69 | 74 | -65 | 1167 | 659 | 421 | 478 | 0 / 0 | 148/110 | 34,9 | - / - | 0 | 0 | 100 | 0 | 80 | 720 | 165 | - | 0,75 |
| M | 450 | 475 | 630 | 155 | 70 | 74 | -60 | 1177 | 663 | 440 | 482 | 0 / 0 | 148/110 | 34,9 | - / - | 0 | 0 | 100 | 0 | 80 | 740 | 165 | - | 0,75 |
| L | 500 | 475 | 660 | 175 | 70 | 74 | -60 | 1209 | 682 | 464 | 474 | 0 / 0 | 148/110 | 34,9 | - / - | 0 | 0 | 100 | 0 | 80 | 740 | 170 | - | 0,75 |

| | STL | CSL | TTL | HTL | HTA | STA | BB | WB | ST | RE | SOH |  |  |  |  |  |  |  |  |  |  |  |  |  |  |
|--|-----|-----|-----|-----|-----|-----|----|----|----|----|-----|---|---|---|---|---|---|---|---|---|---|---|---|---|---|
|--|-----|-----|-----|-----|-----|-----|----|----|----|----|-----|---|---|---|---|---|---|---|---|---|---|---|---|---|---|

E-TERU ADVANCED EQ LOW

| | | | | | | | | | | | | | | | | | | | | | | | | |
|---|-----|-----|-----|-----|----|----|-----|------|-----|-----|-----|-------|---------|------|-------|---|---|-----|---|----|-----|-----|---|------|
| S | 380 | 475 | 610 | 150 | 69 | 74 | -65 | 1167 | 659 | 421 | 478 | 0 / 0 | 148/110 | 34,9 | - / - | 0 | 0 | 100 | 0 | 80 | 720 | 165 | - | 0,75 |
| M | 450 | 475 | 630 | 155 | 70 | 74 | -60 | 1177 | 663 | 440 | 482 | 0 / 0 | 148/110 | 34,9 | - / - | 0 | 0 | 100 | 0 | 80 | 740 | 165 | - | 0,75 |
| L | 500 | 475 | 660 | 175 | 70 | 74 | -60 | 1209 | 682 | 464 | 474 | 0 / 0 | 148/110 | 34,9 | - / - | 0 | 0 | 100 | 0 | 80 | 740 | 170 | - | 0,75 |

| | STL | CSL | TTL | HTL | HTA | STA | BB | WB | ST | RE | SOH |  |  |  |  |  |  |  |  |  |  |  |  |  |  |
|--|-----|-----|-----|-----|-----|-----|----|----|----|----|-----|---|---|---|---|---|---|---|---|---|---|---|---|---|---|
|--|-----|-----|-----|-----|-----|-----|----|----|----|----|-----|---|---|---|---|---|---|---|---|---|---|---|---|---|---|

E-TERU UNIVERSAL EQ LOW

| | | | | | | | | | | | | | | | | | | | | | | | | |
|---|-----|-----|-----|-----|----|----|-----|------|-----|-----|-----|-------|---------|------|-------|---|---|-----|---|----|-----|-----|---|------|
| S | 380 | 475 | 610 | 150 | 69 | 74 | -65 | 1167 | 659 | 421 | 478 | 0 / 0 | 148/110 | 34,9 | - / - | 0 | 0 | 100 | 0 | 80 | 720 | 165 | - | 0,75 |
| M | 450 | 475 | 630 | 155 | 70 | 74 | -60 | 1177 | 663 | 440 | 482 | 0 / 0 | 148/110 | 34,9 | - / - | 0 | 0 | 100 | 0 | 80 | 740 | 165 | - | 0,75 |
| L | 500 | 475 | 660 | 175 | 70 | 74 | -60 | 1209 | 682 | 464 | 474 | 0 / 0 | 148/110 | 34,9 | - / - | 0 | 0 | 100 | 0 | 80 | 740 | 170 | - | 0,75 |

TERU

SUPER FIT
GHOST

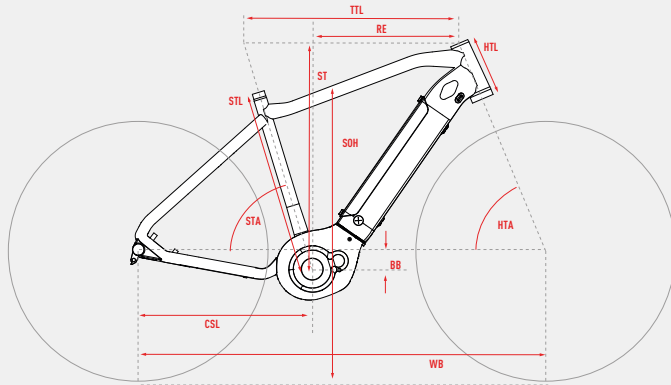

























ALL DIMENSIONS IN MM (EXCEPT HTA AND STA IN °)

ALLE MASSE IN MM (AUSNAHME HTA UND STA IN °)

- STL** SEAT TUBE LENGTH
SITZROHRLÄNGE
- CSL** CHAINSTAY LENGTH
KETTENSTREBENLÄNGE
- TTL** TOP TUBE LENGTH
OBERROHRLÄNGE
- HTL** HEAD TUBE LENGTH
STEUERROHRLÄNGE
- HTA** HEAD TUBE ANGLE
STEUERROHRWINKEL
- STA** SEAT TUBE ANGLE
SITZROHRWINKEL
- BB** BOTTOM BRACKET DROP
INNENLAGERABSINKUNG
- WB** WHEELBASE
RADSTAND
- ST** STACK
STACK
- RE** REACH
REACH
- SOH** STANDOVER HEIGHT
ÜBERSTANDSHÖHE
-  HEAD SET DIAMETER (UPPER / LOWER)
STEUERSATZDURCHMESSER (OBEN / UNTEN)

-  AXLE STANDARD (REAR / FRONT)
ACHSENSTANDARD (HINTEN / VORNE)
-  BOTTOM BRACKET STANDARD
TRETLAGERSTANDARD
-  SEAT POST DIAMETER
SÄTTELSTÜTZENDURCHMESSER
-  SHOCK HARDWARE (Ø 8 MM)
DAMPFERBUCHSENMASSE (Ø 8 MM)
-  SHOCK LENGTH
DAMPFEREINBAULÄNGE
-  SHOCK TRAVEL
DAMPFERHUB
-  FRONT FORK TRAVEL
FEDERWEG VORNE
-  REAR WHEEL TRAVEL
FEDERWEG HINTEN
-  STEM LENGTH
VORBAULÄNGE
-  HANDLEBAR WIDTH
LENKERBREITE
-  CRANK LENGTH
KURBELLÄNGE
-  SEATTUBE BOTTLE MOUNT
FLASCHE SÄTTELROHR
-  DOWNTUBE BOTTLE MOUNT
FLASCHE UNTERROHR

STL CSL TTL HTL HTA STA BB WB ST RE SOH                        

E-TERU ESSENTIAL

| | | | | | | | | | | | | | | | | | | | | | | | | |
|----|-----|-----|-----|-----|----|------|----|------|-----|-----|-----|-------|---------|------|-------|---|---|-----|---|----|-----|-----|------|---|
| S | 400 | 490 | 574 | 125 | 65 | 74.8 | 54 | 1217 | 624 | 405 | 704 | 0 / 0 | 148/110 | 31,6 | - / - | 0 | 0 | 120 | 0 | 45 | 700 | 165 | 0,5 | - |
| M | 450 | 495 | 606 | 120 | 65 | 74.6 | 69 | 1251 | 653 | 427 | 742 | 0 / 0 | 148/110 | 31,6 | - / - | 0 | 0 | 120 | 0 | 45 | 720 | 165 | 0,75 | - |
| L | 490 | 495 | 639 | 135 | 65 | 74.6 | 64 | 1287 | 661 | 456 | 765 | 0 / 0 | 148/110 | 31,6 | - / - | 0 | 0 | 120 | 0 | 45 | 740 | 170 | 0,75 | - |
| XL | 530 | 495 | 671 | 160 | 65 | 74.6 | 64 | 1323 | 683 | 482 | 804 | 0 / 0 | 148/110 | 31,6 | - / - | 0 | 0 | 120 | 0 | 45 | 760 | 170 | 0,75 | - |

TERU

SUPER FIT
GHOST

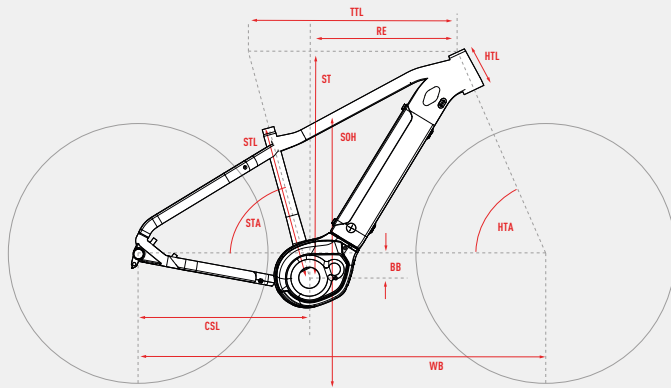







ALL DIMENSIONS IN MM (EXCEPT HTA AND STA IN °)

ALLE MASSE IN MM (AUSNAHME HTA UND STA IN °)

- STL** SEAT TUBE LENGTH
SITZROHRLÄNGE
- CSL** CHAINSTAY LENGTH
KETTENSTREBENLÄNGE
- TTL** TOP TUBE LENGTH
OBERROHRLÄNGE
- HTL** HEAD TUBE LENGTH
STEUERROHRLÄNGE
- HTA** HEAD TUBE ANGLE
STEUERROHRWINKEL
- STA** SEAT TUBE ANGLE
SITZROHRWINKEL
- BB** BOTTOM BRACKET DROP
INNENLAGERABSINKUNG
- WB** WHEELBASE
RADSTAND
- ST** STACK
STACK
- RE** REACH
REACH
- SOH** STANDOVER HEIGHT
ÜBERSTANDSHÖHE
-  HEAD SET DIAMETER (UPPER / LOWER)
STEUERSATZDURCHMESSER (OBEN / UNTEN)

-  AXLE STANDARD (REAR / FRONT)
ACHSENSTANDARD (HINTEN / VORNE)
-  BOTTOM BRACKET STANDARD
TRETLAGERSTANDARD
-  SEAT POST DIAMETER
SÄTTELSTÜTZENDURCHMESSER
-  SHOCK HARDWARE (Ø 8 MM)
DAMPFERBUCHSENMASSE (Ø 8 MM)
-  SHOCK LENGTH
DAMPFEREINBAULÄNGE
-  SHOCK TRAVEL
DAMPFERHUB
-  FRONT FORK TRAVEL
FEDERWEG VORNE
-  REAR WHEEL TRAVEL
FEDERWEG HINTEN
-  STEM LENGTH
VORBAULÄNGE
-  HANDLEBAR WIDTH
LENKERBREITE
-  CRANK LENGTH
KURBELLÄNGE
-  SEATTUBE BOTTLE MOUNT
FLASCHE SÄTTELROHR
-  DOWNTUBE BOTTLE MOUNT
FLASCHE UNTERROHR

STL CSL TTL HTL HTA STA BB WB ST RE SOH                        

E-TERU ESSENTIAL EQ

| | | | | | | | | | | | | | | | | | | | | | | | | |
|----|-----|-----|-----|-----|----|----|----|------|-----|-----|-----|-------|---------|------|-------|---|---|----|---|----|-----|-----|------|---|
| S | 480 | 490 | 545 | 155 | 67 | 73 | 55 | 1176 | 622 | 397 | 754 | 0 / 0 | 148/110 | 31,6 | - / - | 0 | 0 | 80 | 0 | 45 | 720 | 170 | 0,75 | - |
| M | 520 | 490 | 575 | 170 | 67 | 73 | 55 | 1198 | 636 | 414 | 797 | 0 / 0 | 148/110 | 31,6 | - / - | 0 | 0 | 80 | 0 | 45 | 740 | 170 | 0,75 | - |
| L | 560 | 490 | 604 | 180 | 67 | 73 | 55 | 1224 | 645 | 436 | 801 | 0 / 0 | 148/110 | 31,6 | - / - | 0 | 0 | 80 | 0 | 45 | 740 | 175 | 0,75 | - |
| XL | 600 | 490 | 635 | 190 | 67 | 73 | 55 | 1250 | 655 | 458 | 832 | 0 / 0 | 148/110 | 31,6 | - / - | 0 | 0 | 80 | 0 | 45 | 760 | 175 | 0,75 | - |

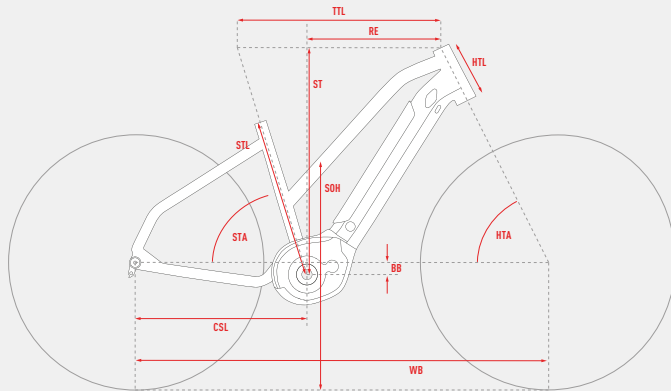

ALL DIMENSIONS IN MM (EXCEPT HTA AND STA IN °)

ALLE MASSE IN MM (AUSNAHME HTA UND STA IN °)

- STL** SEAT TUBE LENGTH
SITZROHRLÄNGE
- CSL** CHAINSTAY LENGTH
KETTENSTREBELÄNGE
- TTL** TOP TUBE LENGTH
OBERROHRLÄNGE
- HTL** HEAD TUBE LENGTH
STEUERROHRLÄNGE
- HTA** HEAD TUBE ANGLE
STEUERROHRWINKEL
- STA** SEAT TUBE ANGLE
SITZROHRWINKEL
- BB** BOTTOM BRACKET DROP
INNENLAGERABSINKUNG
- WB** WHEELBASE
RADSTAND
- ST** STACK
STACK
- RE** REACH
REACH
- SOH** STANDOVER HEIGHT
ÜBERSTANDSHÖHE
- HEAD SET DIAMETER (UPPER / LOWER)**
STEUERSATZDURCHMESSER (OBEN / UNTEN)

- AXLE STANDARD (REAR / FRONT)**
ACHSENSTANDARD (HINTEN / VORNE)
- BOTTOM BRACKET STANDARD**
TRETLAGERSTANDARD
- SEAT POST DIAMETER**
SÄTTELSTÜTZENDURCHMESSER
- SHOCK HARDWARE (Ø 8 MM)**
DAMPFERBUCHSENMASSE (Ø 8 MM)
- SHOCK LENGTH**
DÄMPFEREINBAULÄNGE
- SHOCK TRAVEL**
DÄMPFERHÜB
- FRONT FORK TRAVEL**
FEDERWEG VORNE
- REAR WHEEL TRAVEL**
FEDERWEG HINTEN
- STEM LENGTH**
VORBAULÄNGE
- HANDLEBAR WIDTH**
LENKERBREITE
- CRANK LENGTH**
KURBELLÄNGE
- SEAT TUBE BOTTLE MOUNT**
FLASCHE SÄTTELROHR
- DOWNTUBE BOTTLE MOUNT**
FLASCHE UNTERROHR

STL CSL TTL HTL HTA STA BB WB ST RE SOH

E-TERU ESSENTIAL EQ MID

| | | | | | | | | | | | | | | | | | | | | | | | | |
|---|-----|-----|-----|-----|----|----|----|------|-----|-----|-----|-------|---------|------|-------|---|---|----|---|----|-----|-----|---|---|
| S | 440 | 490 | 580 | 155 | 67 | 73 | 55 | 1169 | 622 | 390 | 601 | 0 / 0 | 148/110 | 31,6 | - / - | 0 | 0 | 80 | 0 | 45 | 720 | 170 | - | - |
| M | 480 | 490 | 595 | 170 | 67 | 73 | 55 | 1184 | 636 | 400 | 601 | 0 / 0 | 148/110 | 31,6 | - / - | 0 | 0 | 80 | 0 | 45 | 740 | 175 | - | - |
| L | 520 | 490 | 613 | 190 | 67 | 73 | 55 | 1205 | 655 | 413 | 600 | 0 / 0 | 148/110 | 31,6 | - / - | 0 | 0 | 80 | 0 | 45 | 740 | 175 | - | - |

STL CSL TTL HTL HTA STA BB WB ST RE SOH

E-TERU

| | | | | | | | | | | | | | | | | | | | | | | | | |
|----|-----|-----|-----|-----|----|------|----|------|-----|-----|-----|-------|---------|------|-------|---|---|-----|---|----|-----|-----|---|---|
| XS | 370 | 490 | 574 | 125 | 65 | 74.8 | 54 | 1217 | 624 | 405 | 620 | 0 / 0 | 148/110 | 31,6 | - / - | 0 | 0 | 120 | 0 | 45 | 700 | 165 | - | - |
|----|-----|-----|-----|-----|----|------|----|------|-----|-----|-----|-------|---------|------|-------|---|---|-----|---|----|-----|-----|---|---|

PATHASKET

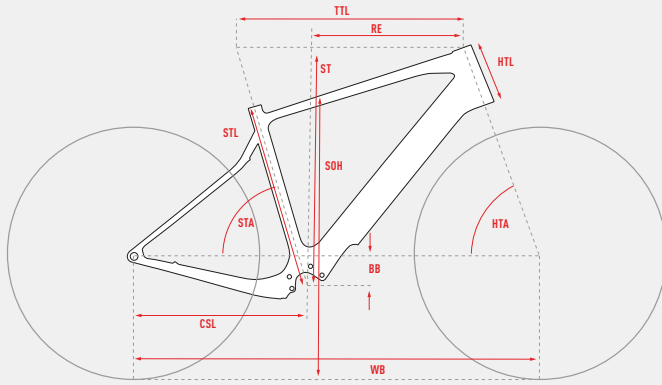

ALL DIMENSIONS IN MM (EXCEPT HTA AND STA IN °)















ALLE MASSE IN MM (AUSNAHME HTA UND STA IN °)

- STL** SEAT TUBE LENGTH
SITZROHRLÄNGE
- CSL** CHAINSTAY LENGTH
KETTENSTREBENLÄNGE
- TTL** TOP TUBE LENGTH
OBERROHRLÄNGE
- HTL** HEAD TUBE LENGTH
STEUERROHRLÄNGE
- HTA** HEAD TUBE ANGLE
STEUERROHRWINKEL
- STA** SEAT TUBE ANGLE
SITZROHRWINKEL
- BB** BOTTOM BRACKET DROP
INNENLAGERABSINKUNG
- WB** WHEELBASE
RADSTAND
- ST** STACK
STACK
- RE** REACH
REACH
- SOH** STANDOVER HEIGHT
ÜBERSTANDSHÖHE
-  HEAD SET DIAMETER (UPPER / LOWER)
STEUERSATZDURCHMESSER (OBEN / UNTEN)

-  AXLE STANDARD (REAR / FRONT)
ACHSENSTANDARD (HINTEN / VORNE)
-  BOTTOM BRACKET STANDARD
TRETLAGERSTANDARD
-  SEAT POST DIAMETER
SÄTTELSTÜTZENDURCHMESSER
-  SHOCK HARDWARE (Ø 8 MM)
DAMPFERBUCHSENMASSE (Ø 8 MM)
-  SHOCK LENGTH
DÄMPFEREINBAULÄNGE
-  SHOCK TRAVEL
DÄMPFERHÜB
-  FRONT FORK TRAVEL
FEDERWEG VORNE
-  REAR WHEEL TRAVEL
FEDERWEG HINTEN
-  STEM LENGTH
VORBAULÄNGE
-  HANDLEBAR WIDTH
LENKERBREITE
-  CRANK LENGTH
KURBELLÄNGE
-  SEAT TUBE BOTTLE MOUNT
FLASCHE SÄTTELROHR
-  DOWNTUBE BOTTLE MOUNT
FLASCHE UNTERROHR





STL CSL TTL HTL HTA STA BB WB ST RE SOH              

PATH ASKET PRO

| | STL | CSL | TTL | HTL | HTA | STA | BB | WB | ST | RE | SOH |  |  |  |  |  |  |  |  |  |  |  |  |  |  |
|----|-----|-----|-----|-----|------|------|----|------|-----|-----|-----|---|---|---|---|---|---|---|---|---|---|---|---|---|---|
| S | 440 | 445 | 564 | 130 | 69.8 | 73.7 | 70 | 1083 | 586 | 394 | 720 | 0 / 0 | 148/100 | 31,6 | - / - | 0 | 0 | 0 | 0 | 0 | 60 | 420 | 170 | 0,5 | 0,5 |
| M | 480 | 450 | 588 | 160 | 70 | 73.7 | 70 | 1110 | 615 | 408 | 760 | 0 / 0 | 148/100 | 31,6 | - / - | 0 | 0 | 0 | 0 | 0 | 60 | 440 | 170 | 0,75 | 0,75 |
| L | 500 | 455 | 616 | 190 | 70.3 | 73.6 | 65 | 1144 | 639 | 429 | 780 | 0 / 0 | 148/100 | 31,6 | - / - | 0 | 0 | 0 | 0 | 0 | 60 | 460 | 175 | 0,75 | 0,75 |
| XL | 540 | 460 | 640 | 220 | 70.5 | 73.6 | 65 | 1171 | 669 | 443 | 820 | 0 / 0 | 148/100 | 31,6 | - / - | 0 | 0 | 0 | 0 | 0 | 60 | 480 | 175 | 0,75 | 0,75 |

STL CSL TTL HTL HTA STA BB WB ST RE SOH              

PATH ASKET ADVANCED

| | STL | CSL | TTL | HTL | HTA | STA | BB | WB | ST | RE | SOH |  |  |  |  |  |  |  |  |  |  |  |  |  |  |
|----|-----|-----|-----|-----|------|------|----|------|-----|-----|-----|---|---|---|---|---|---|---|---|---|---|---|---|---|---|
| S | 440 | 445 | 564 | 130 | 69.8 | 73.7 | 70 | 1083 | 586 | 394 | 720 | 0 / 0 | 148/100 | 31,6 | - / - | 0 | 0 | 40 | 0 | 60 | 420 | 170 | 0,5 | 0,5 | |
| M | 480 | 450 | 588 | 160 | 70 | 73.7 | 70 | 1110 | 615 | 408 | 760 | 0 / 0 | 148/100 | 31,6 | - / - | 0 | 0 | 40 | 0 | 60 | 440 | 170 | 0,75 | 0,75 | |
| L | 500 | 455 | 616 | 190 | 70.3 | 73.6 | 65 | 1144 | 639 | 429 | 780 | 0 / 0 | 148/100 | 31,6 | - / - | 0 | 0 | 40 | 0 | 60 | 460 | 175 | 0,75 | 0,75 | |
| XL | 540 | 460 | 640 | 220 | 70.5 | 73.6 | 65 | 1171 | 669 | 443 | 820 | 0 / 0 | 148/100 | 31,6 | - / - | 0 | 0 | 40 | 0 | 60 | 480 | 175 | 0,75 | 0,75 | |

TECHNIK LEXIKON // TECHNOLOGY GLOSSARY

170
160

FEDERWEG // TRAVEL

ERSTE ZAHL = FEDERWEG VORNE
ZWEITE ZAHL = FEDERWEG HINTEN
FIRST NUMBER = FRONT TRAVEL
SECOND NUMBER = REAR TRAVEL

ONE-PIECE
ROCKER

EINTEILIGE DÄMPFERWIPPE // ONE-PIECE-ROCKER

EINTEILIGES DESIGN FÜR MAXIMALE STEIFIGKEIT // Unsere einteilige Dämpferwippe gibt noch mal ein Extrapuls obenauf: Mehr Steifigkeit führt zu geringerer Querbelastung der Bolzen und des gesamten Hinterbaus.
ONE-PIECE DESIGN FOR MAXIMIZED STIFFNESS // Our one-piece rocker comes with an extra bonus: more stiffness leads to decreased transverse forces on the bolts and the entire rear.

BALL
BEARINGS

VOLLKUGELIGE INDUSTRIELAGER // FULL COMPLEMENT BEARING

DETAILS, DIE SICH LOHNEN // Höchster Standard für alle. Mit den langlebigen, gedichteten Kugellagern sind unsere Mountainbikes bestens gegen alle äußeren Einflüsse geschützt.
DETAILS THAT ARE WORTHWHILE // The highest standard for all! With the long-life, sealed ball bearings our mountain bikes are well protected against dirt, shear forces or wear.

HF-TUBES

HYDROGEFORMTE ROHRSÄTZE // HYDRO-FORMED TUBESETS

PERFEKT GEFORMT FÜR HÖCHSTE ANSPRÜCHE // Der Hydroforming-Prozess erzielt bestmögliche Steifigkeit und optimalen Kraftfluss für jedes einzelne Rahmensegment. So haben wir Freiheit für kreatives Rohrdesign.
PERFECTLY SHAPED FOR HIGH PERFORMANCE // The hydroforming process achieves ultimate rigidity and optimal power flow for each frame segment. This gives us freedom for creative tube design.

PROGRESSIVE
GEOMETRY

FORTSCHRITTLICHE GEOMETRIE // ADVANCED GEOMETRY

MEHR KONTROLLE. MEHR SPASS // Die Trails werden anspruchsvoller und die Fahrer auch: Dafür haben wir moderne Geometrien entwickelt, die jedem Anspruch gerecht werden.
MORE CONTROL. MORE FUN // The trails are becoming more demanding - and the riders as well: That's why we develop modern geometries that are able to meet any demand.

CARBON
FLEX STAYS

CARBON FLEX STAYS // CARBON FLEX STAYS

VERBORGENER SCHATZ FÜR LANGE AUSFAHRTEN // Unsichtbares Plus: Die Flex Stays in der Sitz- und Kettenstrebe geben dem Hinterbau die Möglichkeit, direktional nach oben auszuweichen und sind somit ein dickes Komfort-Plus.
HIDDEN TREASURE ON LONG RIDES // Invisible plus: The flexstays of the seat and chainstays enable the rear triangle to move upward directionally: a huge plus in comfort.

FORGED
DROPOUT

GESCHMIEDETE AUSFALLENDEN // FORGED DROPOUT

WIE ANGENOSSEN // Unsere geschmiedeten Ausfallenden sind hochwertig verarbeitet, erzielen besonders hohe Steifigkeitswerte und integrieren sich zudem perfekt in unser Rahmendesign.
THE PERFECT FIT // Our forged dropouts are manufactured to a high quality, obtaining particularly high stiffness values, and are perfectly integrated into our frame design.

FORGED
YOKES

GESCHMIEDETE KETTENSTREBENBRÜCKE // FORGED CHAINSTAY YOKE

GESCHMIEDETE LÖSUNG // Die Verbindung von Kettenstrebe und Tretlager ist eine ganz entscheidende Stelle am Bike. Durch unsere aufwendige Schmiede-Lösung erreichen wir eine sehr hohe Steifig- und Festigkeit.
FORGED SOLUTION // The connection between the chainstay and bottom bracket is a very crucial point on the bike. With our elaborate forged solution we achieve a very high degree of stiffness and strength.

GHOST
FORK

GHOST-GABELSYSTEM // GHOST FORK SYSTEM

ALUMINIUM ODER CARBON - SELBST ENTWICKELT // Unsere eigenen Gabeln sind das Tüpfelchen auf dem i. Speziell für cleane und superschnelle Bikes haben wir optimierte Lösungen geschaffen.
ALUMINIUM OR CARBON, SELF-DEVELOPED // Our own forks are the icing on the cake. We created optimum solutions particularly for clean and fast bikes.

VARIO
FORK

ABSENKBARE FEDERGABEL // VARIO FORK

ZWEI GABELN IN EINER // Tiefe Front für den Anstieg und voller Federweg für die Abfahrt. Die Federgabeln mit zwei unterschiedlichen Federwegslängen verändern den Charakter des Bikes maßgeblich.
ONE SUSPENSION FORK, TWO OPTIONS // Low front for the climb, and the entire travel for the downhill. The suspension forks with two different positions considerably change the bike's personality.

INNER
ROUTING

INNEN VERLEGTE ZÜGE // INNER ROUTING

SAUBERE SACHE MIT SUPER SCHUTZ // Innen verlegte Züge und Leitungen sind besser gegen äußere Einflüsse geschützt und sorgen für eine cleane Optik am Bike.
KEEPING IT CLEAN WITH SUPER PROTECTION // Better protection and a cleaner look: The main advantages of internal cables and routing.

INVISIBLE
ROUTING

UNSICHTBARE KABELFÜHRUNG // INVISIBLE CABLE ROUTING

SAUBER VERLEGT, LEICHT ZUGÄNGLICH // Unsichtbar verlegt, aber trotzdem offen zugänglich: Mit der speziellen Form des Unterrohrs lassen wir die Züge verschwinden. Sollte mal etwas sein, kommt man aber immer noch ohne großen Aufwand dran.
INVISIBLY ROUTED, YET EASILY ACCESSIBLE // Invisibly routed, yet still easily accessible: The cables disappear invisibly in the unique shape of our downtube. If needed, easy access is guaranteed.

ISCG 05

ISCG 05 // ISCG 05

INTERNATIONALER STANDARD FÜR INTEGRIERTEN SCHUTZ // Der International Standard Chain Guide ist eine genormte 3-Punkt-Befestigung von Kettenführungen direkt am Tretlagergehäuse. Bei der Montage von Kettenführungen muss das Tretlager nicht mehr ein- oder ausgebaut werden.
INTERNATIONAL STANDARD FOR INTEGRATED PROTECTION // The International Standard Chain Guide is a standardized 3-point mount chain guide installed directly on the bottom bracket shell. When mounting chain guides the bottom bracket no longer needs to be installed or removed.

THROUGH
AXLE

STECKACHSEN-STANDARD // THROUGH-AXLE STANDARD

MEHR KONTROLLE AUF DEN TRAILS // Ein Standard, der bei abfahrtslastigen Bikes ein Muss ist. Die Steckachse ermöglicht ein noch steiferes Dreieck im Hinterbau und führt zu einer besseren Kräfteleitung und -verteilung.
MORE CONTROL ON THE TRAILS // A standard that is a "must" in downhill-focused bikes. The thru-axle allows for an even stiffer rear triangle and guarantees improved force transmission and distribution.

PROTECTION

RAHMENSCHUTZ // FRAME PROTECTION

SCHÜTZ DEIN RAD // Bei fast allen Fullys und den Carbon-Hardtails Standard: unser Rahmenschutz. Denn geschützt fährt's sich am besten!
PROTECT YOUR BIKE // Standard on almost all full-suspensions and carbon hardtails - our frame protection. Protection guarantees the best rides!

BOOST

BOOST STANDARD // BOOST STANDARD

BREITER IST BESSER // Boost bedeutet breitere Naben. So einfach das ist, so groß ist die Verbesserung: Breitere Naben bringen mehr Stabilität.
WIDER IS BETTER // Boost means wider hubs. A small adjustment for a great improvement: Wider hubs bring more stability.

BIKE
READY

RACE READY // RACE READY

WETTKAMPFORIENTIERT // Wir wissen, was es auf der Strecke braucht. Zum einen, weil unsere Teamfahrer uns ständig mit viel Feedback versorgen. Zum anderen besteht unser Entwicklungsteam selbst aus ehemaligen (und teils noch aktiven) Rennfahrern. So liefern wir ein renntaugliches Produkt, das aus dem Karton bereit für die Strecke ist.
A COMPETITIVE SPIRIT // We know what is needed on the track. First, because our team riders constantly provide us with a lot of feedback. Second, our development team itself is made up of former (and still partly active) racers. That's how we deliver a race-ready product: ready for the track right out of the box.

FEM

FEM-BERECHNET // FEM CALCULATED

KOMPLEXE BERECHNUNGEN FÜR UNKOMPLIZIERTE LÖSUNGEN // Unsere FEM-optimierten Rahmen wurden mit aufwendigen Kalkulationen bis ins letzte Detail verbessert. Dadurch ergeben sich simple Lösungen, die aber viel komplexer sind, als man vermutet.
COMPLEX CALCULATIONS FOR UNCOMPLICATED SOLUTIONS // Our optimized FEM frames have been improved with complex calculations down to the last detail. The resulting, seemingly simple solutions are much more complex than they appear.

BOTTLE
READY

VORBEREITET FÜR TRINKFLASCHENHALTER // BOTTLE READY

ERFRISCHENDER STAURAUHM VORPROGRAMMIERT // Hier gibt's genügend Platz für eine Erfrischung unterwegs. Bei Bikes mit diesem Symbol, bekommst du locker eine Trinkflasche im Rahmendreieck unter.
DESIGNED WITH TRULY REFRESHING STORAGE IN MIND // There's plenty of space for refreshments. Bikes featuring this symbol provide enough space for a bottle.

VARIO
READY

VORBEREITUNG FÜR INNEN VERLEGTE TELESKOPSTÜTZE // READY FOR DROPPER SEATPOST

ABSENKEN FÜR MEHR FREIHEIT // Unsere Rahmen sind bereit für absenkbare Sattelstützen: Die Zugführung lässt sich sauber und gut geschützt innen verlegen.
LOWER FOR MORE FREEDOM // Our frames are already prepared for dropper seat posts: The cables can be routed inside the tubes for a clean look and better protection.

BOSCH
SMART
SYSTEM

BOSCH SMART SYSTEM // BOSCH SMART SYSTEM

DIE NÄCHSTE STUFE // Mit dem neuen smarten System hebt Bosch das E-Bike auf das nächste Level. Die vollvernetzte Kombination aus Akku, Display, Drive Unit und eBike Flow App sorgt für ein neues E-Bike Erlebnis.
THE NEXT LEVEL // With the new smart system, Bosch is taking e-bikes to the next level. The fully networked combination of battery, display, drive unit and eBike Flow app ensures a new e-bike experience.

BOSCH
MOTOR

BOSCH MOTOR // BOSCH MOTOR

BEWAHRTER ANTRIEB MIT ORDENTLICH VORTRIEB // Diese bereits bekannten Elektroantriebe garantieren hervorragende Qualität, Leistungsfähigkeit und Langlebigkeit in praktischem Design.
A PROVEN MOTOR WITH RESPECTABLE POWER // These well-known electric drives guarantee excellent quality, performance and durability in a compact design.

FULLY
INTEGRATED

VOLL-INTEGRIERTER AKKU // FULLY INTEGRATED BATTERY

GUT VERSTAUT // Mit geringstem Materialaufwand optisch schick integriert: die neuen Bikes mit Vollintegration.
NEATLY HIDDEN // Artfully integrated and looking like a million bucks without spending a lot on materials: the new bikes with full-integration.

MXeT
CONCEPT

HYBRIDE MXER-KONZEPT // HYBRIDE MXER CONCEPT

DIE ANTWORT AUF BESTE PERFORMANCE // MXer klingt wie Motocross? Richtig. Großes, schmales 29" Vorderrad und kleines, breites 27.5" Hinterrad sorgen für beste Spurführung und Überrollverhalten sowie maximale Traktion und Kraftübertragung am Heck.
THE ANSWER FOR BEST PERFORMANCE // MXer sounds like Motocross? Correct. A big, slim 29" front wheel and a small, wide 27.5" rear wheel guarantee great directional stability, low rolling resistance, maximum traction and power transmission at the rear.

SHORT
CRANK

KURZE EMTB-KURBEL // SHORT EMTB CRANK

MEHR KURBELN STATT KÄMPFEN // Nicht nur mehr Bodenfreiheit, sondern auch eine bessere Motorleistung dank kürzerer Kurbeln: Diese führen automatisch zu höherer Trittfrequenz und lassen die Motoren in einer besseren Kraftzone arbeiten.
MORE PEDALING, LESS STRUGGLING // Shorter cranks mean not only more ground clearance, but also improved motor use: They automatically result in a higher cadence and make the motor work in an improved power zone.

DISC
BRAKE

SCHIEBENBREMSE // DISC BRAKE

BESTE BREMSKRAFT, BESTENS DOSIERBAR // Ob in der Stadt oder im Gelände: Die hydraulischen Scheibenbremsen greifen auch bei Nässe zuverlässig sicher und schnell.
BEST BRAKING POWER, WITH EXCEPTIONAL CONTROL // Whether in town or on terrain: The hydraulic disc brakes guarantee a safe and fast grip even in wet conditions.

COIL
SHOCK

STAHLFEDERDÄMPFER // COIL SHOCK

UNKOMPLIZIERT UND ZUVERLÄSSIG // Weniger Wartungsaufwand, höhere Zuverlässigkeit, unerreichbare Performance und einfaches Set-up. Wer sich Zeit, Aufwand und Dämpfer-Pumpe sparen will, der liegt mit einem Stahlfederdämpfer absolut richtig.
UNCOMPLICATED AND RELIABLE // Less maintenance, higher reliability, unbeatable performance and easy setup. For those who want to save time, effort and shock pump, a coil shock is just up their alley.

ENCAP
SHIFTING

GEKAPSELTE SCHALTUNG // ENCAPSULATED SHIFTING

GUT GESCHÜTZTER ANTRIEB // Das kompakte Nabenge triebe ist nicht nur unsichtbar versteckt, sondern auch abgeschirmt vor Schmutz und dadurch deutlich weniger empfindlich oder verschleißanfällig.
WELL PROTECTED DRIVE // The compact hub transmission is not only tucked away to make it invisible, but is also properly shielded against dirt and thus much less sensitive or susceptible to wear.



EINFACH-ANTRIEB // 1-BY DRIVETRAIN

WENIGER TEILE, WENIGER STRESS // Vergiss den 2. Shifter, den Umwerfer und den Schaltzug dorthin: Beim Einfach-Antrieb kannst du dir das alles sparen. Weiterer Pluspunkt: Die Kette klappert nicht und fällt auch nicht mehr ab.
LESS PARTS, LESS HASSLE // Forget about the second shifter, the front derailleur and the cables there; with the 1-by drivetrain you don't need any of those things. No more chain slapping either. And your chain jumping off the gear is so yesterday.



RIEMENANTRIEB // BELT DRIVE

ZUVERLÄSSIG BEI JEDER WITTERUNG // Keine Schmiere, kein Dreck, weniger Verschleiß und bestens geschützte Hosenhose. Was will man mehr für den Weg ins Büro?
RELIABLE IN EVERY CONDITION // No grease, no dirt, less wear and well protected pant legs. What more do you need for your commute to the office?



TELESKOPSTÜTZE // DROPPER POST

MEHR PLATZ, WENN'S HEISS HERGEHT // Per Fernbedienung absenkbarer Sattelstütze: Eine großartige Erleichterung, wenn der Trail steil wird.
DROP IT WHEN THE TRAIL GETS ROUGH // Remote-controlled seatpost: a great help when the trail gets steep.



VORBEREITET FÜR BIKEPACKING // BIKEPACKING READY

MACH DEIN BIKE ZUM LASTENTIER // Für Packkünstler und Weltenbummler: An diese Aufnahmen lässt sich quasi alles befestigen.
MAKE YOUR BIKE A REAL WORKHORSE // For packing artists and globetrotters: You can attach pretty much anything to these mounts.



MTB-LENKZENTRALE // MTB COCKPIT

MOUNTAINBIKE-TECHNIK AUCH FÜR DEN GROSSSTADTOSCHNUNGEL // Unsere DNA aus dem Mountainbikebereich ist auch auf den urbanen Strecken kein Nachteil: Beste Kontrolle und angenehme Ergonomie sind nie verkehrt.
MOUNTAIN BIKE TRICKERY FOR THE URBAN JUNGLE // Our DNA from the mountain bike sector certainly is no disadvantage on urban trails either: optimum control and comfortable ergonomics always feel good.



NABENDYNAMO // HUB DYNAMO

ZUVERLÄSSIG, WARTUNGSARM UND VOLLER ENERGIE // Die Nabendynamos liefern leise und leichtgängig viel Energie für zuverlässige Beleuchtung. Neben dem hohen Wirkungsgrad sind sie auch noch robust und wartungsarm.
RELIABLE, LOW MAINTENANCE AND FULL OF ENERGY // The hub dynamos quietly and smoothly deliver a lot of energy for reliable lighting. Not only are they highly efficient, they are also robust and require low maintenance.



INTEGRIERTE BELEUCHTUNG // INTEGRATED LIGHTING

UNAUFFALLIG LEUCHTENDES BEISPIEL // Minimalistisches Design, maximale Funktion: Die Kabel unserer hochwertigen Lampen verschwinden sauber und gut geschützt im Schutzblech.
AN UNOBTUSIVE SHINING EXAMPLE // Minimalist design, maximum functionality: The cables of our high-quality lamps disappear completely and are well protected in the mudguard.



USB-LADEBUCHSE // USB CHARGER

UNTERWEGS AUFLADEN // Wir integrieren den Energielieferanten ins Rad: An der Lenkzentrale kann man seine Geräte unterwegs über die USB-Schnittstelle aufladen. Gespeist wird sie durch den Nabendynamo, wobei das Kabel sauber durch die Gabel verläuft.
CHARGING ON THE GO // We integrate the energy source into the bike: On the handlebars you can charge your devices on the go via the USB interface. It is powered via the hub dynamo, with the cable running cleanly through the fork.



VORBEREITET FÜR FAHRADSTÄNDER // KICK STAND READY

VORBEREITET AUF ALLES // Falls ihr mal einen sicheren Stand braucht: Diese Bikes sind dafür vorbereitet.
PREPARED LIKE SECOND TO NONE // In case you need a safe stand at some point: These bikes are ready for an upgrade.



INTEGRIERTE FAHRADSTÄNDER // INSTALLED KICK STAND

DER SICHERE STAND FÜR DEIN BIKE // Damit du dein Bike immer und überall sicher abstellen kannst, haben wir es mit einem Fahrradständer ausgestattet. Nie wieder nervige „Parkplatzsuche“.
YOUR BIKE STANDING SAFELY // To place your bike safely anytime and anywhere, we have equipped it with a secure kick stand. No more annoying search for a parking space.



EXTRA STEIFE SCHUTZBLECHE // EXTRA STRONG FENDERS

CLEAN IM DOPPELTEN SINNE // Selbst am Schutzblech kann man tüfteln: Durch unsere extrem steife Schutzblech-Konstruktion können wir auf zusätzliche Streben verzichten. Das spart nicht nur Gewicht, sondern sorgt auch für eine super cleane Optik.
CLEAN IN BOTH SENSES // Even mudguards you can tinker with: Through our extremely stiff mudguard design we can do without additional struts. This not only saves weight, but also ensures a minimalist look.



VORBEREITET FÜR SCHUTZBLECHE // FENDER READY

SAUBER BLEIBEN // Wer Matsch- und Wasserspritzer abhalten will, der kann unsere Rahmen unkompliziert mit Schutzblechen nachrüsten.
STAY CLEAN // Anyone who wants to keep mud and water splashes at bay can easily retrofit their bike with mudguards.



VERBAUTE SCHUTZBLECHE // INSTALLED FENDERS

DEIN SCHUTZ GEGEN DRECK // Für alle, die ihre Kleidung vor Schmutzspritzern schützen wollen: Diese Bikes haben die Schutzbleche bereits montiert.
YOUR PROTECTION AGAINST DIRT // For everyone who wants to protect their clothing from splashes of dirt: these bikes have already mounted the fenders.



INTEGRIERTER GEPÄCKTRÄGER // INTEGRATED CARRIER

ELEGANT UNAUFFÄLLIG UND TROTZDEM BELASTBAR // Unser Gepäckträger ist schlicht und einfach. Im elegant unauffälligen Design steckt aber eine extrem steife, robuste Konstruktion, die mit 25 Kilo belastbar und mit den gängigen Taschensystemen von anderen Anbietern kompatibel ist.
ELEGANTLY INCONSPICUOUS, YET RESILIENT // Our luggage rack is plain and simple. However, the elegant and discrete design brings an extremely rigid, robust construction that can take loads of up to 25 kg and is compatible with the usual bag systems of other manufacturers.



INTEGRIERTER SEITENTASCHENTRÄGER // INTEGRATED PANNIER BAG CARRIER

STYLISCH, STARK UND TRAGFÄHIG // Das stylische Äußere unseres urbanen Gepäckträgers soll nicht täuschen: Die Konstruktion fügt sich optisch perfekt in das schlichte Gesamtbild ein, ist aber durchaus gut belastbar. Seitlich lassen sich Packtaschen anbringen.
STYLISH, STRONG AND SOUND // Don't be fooled by the stylish exterior of our urban luggage rack: The structure fits perfectly into the minimalist overall picture, yet is exceptionally sturdy. Panniers can also be fitted to the sides.



HERAUSNEHMBARE BATTERIE // REMOVEABLE BATTERY

GUT VERSTAUT MIT FLEXIBLEN LADEOPTIONEN // Die In-Tube Batterien lassen sich einfach aus dem Rahmen entnehmen und können somit überall geladert und geladen werden. Auch größeren Touren steht nichts im Wege, denn ein zweiter Akku kann schnell eingesteckt werden.
WELL PLACED WITH FLEXIBLE CHARGING OPTIONS // In-tube batteries can be easily removed from the frame for storage or charging anywhere. Even longer tours are no problem, a second battery can be quickly inserted.



KABELABDECKUNG // CABLE COVER

DESIGN TRIFFT FUNKTION // Kabelführungen benötigen einen festen Sitz und wollen versteckt sein. Unter der Kabelabdeckung am Unterrohr sind sie perfekt verstaut. Mit Hilfe des Snap-Lock Verschlusses am Cover lassen sich die Kabel werkzeuglos und im Handumdrehen für einen schnellen Service freilegen.
DESIGN MEETS FUNCTION // Cable guides need a firm fit and want to be hidden. They are perfectly stowed away under the cable cover on the down tube. With the help of the snap lock on the cover, the cables can be exposed without tools in no time at all for quick service.



FAZUA RIDE 60 ANTRIEBSSYSTEM // FAZUA RIDE 60 ENGINE

LEISE, KOMPAKT UND KRAFTVOLL // Der Antriebshersteller aus Ottobrunn bei München präsentiert ein Gesamtsystem, das mit seiner Kombination aus Kraft, intuitiver Bedienung und Leichtigkeit ein besonders agiles, natürliches und nahezu geräuschloses Fahrerlebnis schafft. Über alle Kategorien hinweg: RIDE 60 ist die ideale Unterstützung für smarte Commuter, ausdauernde Gravel-Biker und anspruchsvolle E-Mountainbiker.
QUIET, COMPACT AND POWERFUL // The drive manufacturer from Ottobrunn near Munich, presents a system that, with its combination of power, intuitive operation and lightness, creates a particularly agile, natural and almost effortless riding experience across all categories. RIDE 60 is the supreme assistance for smart commuters, adventurous gravel cyclists and demanding e-mountainbikers.



EINTEILIGER HINTERBAU // ONE-PIECE REAR TRIANGLE

EINFACH, SCHLICHT UND STEIF // Eine einteilige Hinterbau-Konstruktion bietet hohe Steifigkeit, da der Hinterbau aus festen Verbindungen besteht.
EASY, SIMPLE AND STIFF // A one-piece rear triangle construction made of solid connections offers high stiffness.



EINTEILIGER HEBEL // ONE-PIECE LINK

EINTEILIGES DESIGN FÜR MAXIMALE STEIFIGKEIT // Der einteilige Umlenkhebel bietet mehr Gegenhalt für Querbelastungen. Somit werden Belastungen an den Lagerstellen und am gesamten Hinterbau minimiert.
ONE-PIECE DESIGN FOR MAXIMUM STIFFNESS // The one-piece bell crank provides more counter support for lateral stress. This minimizes stress on the bearings and the entire rear triangle.



TRACTIONLINK // TRACTIONLINK

PERFEKT ABGESTIMMTES FAHRWERK // TractionLink sorgt dafür, dass dein Bike nie an Bodenhaftung verliert, egal wie unwegsam das Gelände wird. Die Kinematik zeichnet sich durch ein besonders ausgewogenes Verhältnis zwischen Antriebsneutralität und Hinterradperformance aus. Der Federweg wird optimal genutzt, Schläge werden souverän absorbiert und Bremsstötter gehören der Vergangenheit an.
ALWAYS PUSH ON THE TRAIL // TractionLink ensures that your bike never loses traction, no matter how rough and wild the terrain becomes. The kinematics of our new RIOT is characterized by an especially well-balanced relation between pedaling efficiency and rear triangle performance. The travel is optimally used, impacts are confidently absorbed and brake stuttering is a thing of the past.



SRAM UDH SCHALTAUGE // SRAM UDH DERAILLEUR HANGER

WIR LIEBEN STANDARD // Ein Schaltauge für alle. Um es für alle einfacher zu machen, benötigt es mehr Standards. Von SRAM kommt jetzt das „Universal derailleur hanger“ zum Einsatz, das nicht nur die Zahl an Ersatzteilen reduziert, sondern das Schaltwerk auch vor Schäden schützt, indem es bei Schlägen nach hinten weglappt.
WE LOVE STANDARD // One derailleur hanger for all. To make it easier for everyone, we need more standards. SRAM now uses the „Universal derailleur hanger“, which not only reduces the number of spare parts, but also protects your rear derailleur from damage by folding backwards at impact.



SMARTTUBE WERKZEUGE // SMARTTUBE TOOLS

WERKZEUG SMART VERSTECKT // Mit den extrem leichten, aber robusten Smarttube Tools lassen sich die wichtigsten Werkzeuge, die man beim Biken braucht, einfach im Lenker verstauen. Das Minitool beinhaltet vier Sechskant und einen Torx 25 Aufsatz. Der Smarttube Kettentennier kommt mit Tubeless Repair Funktion, Tubeless Plugs und einer Aufnahme für ein Kettenschloss.
CLEVERLY HIDDEN TOOLS // With the extremely light but robust Smarttube tools, the most important tools you need when biking can be easily stored in the handlebars. The minitool includes four hexagons bits and a Torx 25. The Smarttube chain tool has a tubeless repair function, tubeless plugs and a magnetic mount for a chain lock.



EIGHTPINS SATTELSTÜTZE // EIGHTPINS DROPPER POST

DIE REVOLUTIONIERTE SATTELSTÜTZE // Durch diese Sattelstütze kommt jeder Fahrer auf den Genuss des vollen Hubes, denn sie kann an jede Körpergröße und jeden Fahrstil angepasst werden.
THE REVOLUTIONIZED DROPPER POST // With this seat post, every rider can enjoy the full stroke as it can be adapted to any height and riding style.



SINGLE SPEED // SINGLE SPEED

WEIL EINFACH EINFACH IST // Kein Shifter, kein Schaltwerk mehr – weil weniger manchmal mehr ist, setzen wir bei einigen Bikes auf einen Single Speed Antrieb.
BECAUSE SIMPLY IS SIMPLE // No more shifter, no more rear derailleur – because less is sometimes more, we use a single speed drive for some bikes.



VIERGELLENK-HINTERBAU // 4-BAR-LINKAGE

DAS BESTE AUF JEDEM TRAIL // Seit Jahren bewährt: Dieses verlässliche Fahrwerk arbeitet nach einem fortschrittlichen Prinzip, bei dem die Bremskräfte die Federungsfunktion nicht beeinflussen. So sind maximale Tritteffizienz und Traktion garantiert – bergauf und bergab.
THE BEST ON EVERY TRAIL // Proven for years – the reliable rear suspension works according to a progressive principle in which the braking forces do not affect the suspension function. This guarantees maximum pedaling efficiency and traction – uphill and downhill.



VORBEREITET FÜR RANGE EXTENDER // RANGE EXTENDER READY

LUST AUF MEHR? // Mit dem Zusatzakku kannst du dir optional 210 WH extra Power gönnen. Dieser ergänzt die Leistung des Hauptakkus oder ersetzt diesen sogar.
WANT MORE? // With the Range Extender you get additional 210 WH power. This battery will supplement the main battery or even replace it.



COMPLETE LOCKOUT // VOLLSTÄNDIGER LOCKOUT

Mehr Kontrolle oder mehr Federweg // Die Lockout Funktion der Gabel und des Dampfers kannst du in Sekunden vom Lenker aus steuern. So kannst du das Maximum aus deinem Bike herausholen.
MORE CONTROL OR MORE TRAVEL? // You can control the lockout function of the fork and the damper remotely from the handlebar in mere seconds. That's how you get the maximum out of your bike.



SCHLAUCHLOS // TUBELESS

NIE WIEDER LÖCHER IM SCHLAUCH // Schlauchlos-Bereifung bietet eindeutige Vorteile bei Schnelligkeit, Komfort, Grip und Pannensicherheit. Zusätzlich verbauen wir Tire Noodles um die Felge zu schützen. Für den Notfall liefern wir zudem ein Reparaturkit für den Mantel mit.
NO MORE HOLES IN TUBES // Tubeless tires offer clear advantages in speed, comfort, grip and puncture resistance. Additionally a built in tire noodle offers extra protection for the rim. For emergencies we also include a tire repair kit.

EINSATZBEREICHE // RANGE OF USE

Jedes Fahrrad wurde für einen bestimmten Gebrauch beziehungsweise Einsatzbereich entwickelt und gebaut. Dieser Abschnitt erklärt diese Einsatzbereiche und gibt Auskunft über das maximal zulässige Gesamtgewicht bzw. Fahrergewicht.

Das **Gesamtgewicht (A)** setzt sich zusammen aus dem Gewicht des Fahrrads, des fahrfertig bekleideten Fahrers und des Gepäcks.

Das **Fahrergewicht (B)** setzt sich zusammen aus dem Gewicht des fahrfertig bekleideten Fahrers und des Gepäcks.

Each bicycle is designed for a specific range of use. This section explains those ranges and the weight limits.

The **total weight (A)** equals the weight of the bicycle plus fully geared rider plus luggage.

The **riders weight (B)** equals the weight of the fully geared rider plus luggage.

A MAXIMAL ZULÄSSIGES GESAMTGEWICHT //
MAX. ALLOWED TOTAL WEIGHT

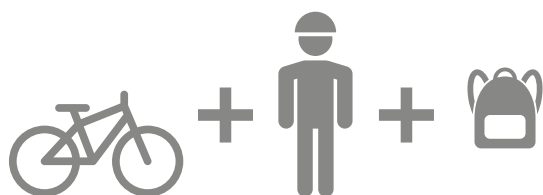

B MAXIMAL ZULÄSSIGES FAHRERGEWICHT //
MAX. ALLOWED RIDER'S WEIGHT

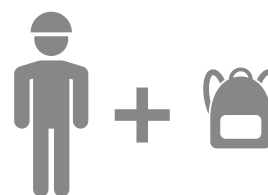

ACHTUNG

Fahrräder sind stets entsprechend ihrem zugelassenen Einsatzbereich zu verwenden. Wird ein Fahrrad höheren Belastungen ausgesetzt, als von uns in der jeweiligen Kategorie empfohlen, kann das zu Beschädigungen des Materials und sogar zum Bruch führen. Ein beschädigtes Fahrrad kann unkontrollierbar werden und dadurch schwere Stürze verursachen.

Beachten Sie auch die Betriebsanleitung des jeweiligen Fahrrads.

WARNING







Bikes always have to be used within and according to their range of use. If a bike is exposed to more stress than intended in its specific range of use, the bicycle and/or its parts may be damaged or break. A damaged or broken bike may be difficult or impossible to control and may cause severe crashes.

Always pay attention to the operating manual of the respective bicycle as well.







EINSATZBEREICHE // RANGE OF USE

| MODELL // MODEL | KATEGORIE EINSATZBEREICH // RANGE OF USE CATEGORY | MAX. ZULÄSSIGES GESAMTGEWICHT (*max. zulässiges Fahrergewicht) // MAX. ALLOWED TOTAL WEIGHT (*max. allowed riders weight) |
|--|--|--|
| RIOT EN | 4 | 120 kg |
| RIOT AM | 4 | 120 kg |
| RIOT TRAIL | 4 | 120 kg |
| LECTOR FS | 3 | 120 kg |
| LECTOR | 3 | 120 kg |
| NIRVANA TOUR | 3 | 120 kg |
| NIRVANA TRAIL | 3 | 120 kg |
| NIRVANA 4X | 4 | 120 kg |
| KATO FS | 4 | 120 kg |
| KATO | 3 | 120 kg |
| LANAO | 3 | 120 kg |
| RIOT YOUTH | 4 | 120 kg |
| KATO YOUTH | 3 | 120 kg |
| LANAO YOUTH | 3 | 120 kg |
| KATO 24 | 2 | 60 kg |
| KATO 20 | 2 | 60 kg |
| LANAO 24 | 2 | 60 kg |
| LANAO 20 | 2 | 60 kg |
| POWERKID 16 | 0 | 30 kg |
| POWERKID 12 | 0 | 30 kg |
| POWERKIDDY 12 | 0 | 30 kg |
| SQUARE TREKKING | 2 | 120 kg |
| SQUARE CROSS | 2 | 120 kg |
| ASKET | 3 | 120 kg |
| PATH RIOT | 4 | 120 kg |
| E-RIOT EN | 4 | 120 kg |
| E-RIOT AM | 4 | 120 kg |
| E-RIOT TRAIL | 4 | 120 kg |
| E-ASX 160 | 4 | 120 kg |
| E-ASX 130 | 4 | 120 kg |
| E-TERU (PRO, ADVANCED, UNIVERSAL, ESSENTIAL) | 3 | 130 kg |
| E-TERU EQ | 2 | 130 kg |
| E-TERU | 2 | 120 kg |
| PATH ASKET | 3 | 120 kg |

EINSATZBEREICHE

| Symbol | Fahrzeugkategorie | Nutzung |
|---|--|--|
|  | <p>Fahrzeuge der Kategorie 0 sind in der Regel Kinderspielräder 12" und Kinderräder 12" und 16".</p> | <p>KATEGORIE 0:</p> <ul style="list-style-type: none"> - Für Kinder ab 3 Jahren - Verwendung nur unter Aufsicht Erziehungsberechtigter - Teilnahme an dem Straßenverkehr ist nicht gestattet - Teilnahme an Wettkämpfen ist nicht gestattet - Nicht für Sprünge und akrobatische Handlungen geeignet |
|  | <p>Fahrzeuge der Kategorie 1 sind in der Regel Fahrräder, Pedelecs und S-Pedelecs des Typs Rennrad oder Fitness Bike (Urban Bike).</p> | <p>KATEGORIE 1:</p> <ul style="list-style-type: none"> - Ausschließlich für asphaltierte, betonierte oder gepflasterte Straßen und Wege - Permanenter Bodenkontakt der Laufräder muss gewährleistet sein - Die Teilnahme an Wettkämpfen ist gestattet - Nicht für Drops, Sprünge und akrobatische Handlungen geeignet |
|  | <p>Fahrzeuge der Kategorie 2 sind in der Regel Fahrräder, Pedelecs und S-Pedelecs des Typs City-, Trekking-, Cross-Trekking- oder Lastenrad, außerdem Kinderräder 20" und Jugendräder 24".</p> | <p>KATEGORIE 2:</p> <ul style="list-style-type: none"> - Beinhaltet Kategorie 1 sowie befestigte und naturfeste Wege mit moderaten Steigungen - Absätze von bis zu 15 cm, z. B. Bordsteinkanten, können hinuntergefahren werden - Die Teilnahme an Wettkämpfen ist nicht gestattet - Nicht für Sprünge und akrobatische Handlungen geeignet |
|  | <p>Fahrzeuge der Kategorie 3 sind in der Regel Fahrräder, Pedelecs und S-Pedelecs des Typs Mountainbike mit Einsatzzweck Cross Country, Marathon und Tour sowie Fahrräder aus den Bereichen Cyclo-Cross und All Track.</p> | <p>KATEGORIE 3:</p> <ul style="list-style-type: none"> - Beinhaltet Kategorien 1 und 2 sowie raue Trails mit kleineren Hindernissen und unbefestigte Strecken, die eine gute Fahrtechnik erfordern - Die Teilnahme an Wettkämpfen ist gestattet - Drops und Sprünge bis zu einer Höhe von max. 60 cm sind zulässig (unter der Voraussetzung entsprechender Fahrtechnik) - Nicht für akrobatische Handlungen geeignet |
|  | <p>Fahrzeuge der Kategorie 4 sind in der Regel Fahrräder, Pedelecs und S-Pedelecs des Typs Mountainbike mit Einsatzzweck Allmountain.</p> | <p>KATEGORIE 4:</p> <ul style="list-style-type: none"> - Beinhaltet Kategorien 1, 2 und 3 - Größere Hindernisse und höhere Geschwindigkeiten setzen gesteigertes fahrerisches Können voraus - Die Teilnahme an Wettkämpfen ist gestattet - Drops und Sprünge bis zu einer Höhe von max. 120 cm sind zulässig (unter der Voraussetzung entsprechender Fahrtechnik) - Nicht für akrobatische Handlungen geeignet |
|  | <p>Fahrzeuge der Kategorie 5 sind in der Regel Fahrräder, Pedelecs und S-Pedelecs des Typs Mountainbike mit Einsatzzweck Enduro/Freeride/Downhill.</p> | <p>KATEGORIE 5:</p> <ul style="list-style-type: none"> - Beinhaltet Kategorien 1, 2, 3 und 4 sowie sehr schnell gefahrenes und sehr anspruchsvolles Gelände mit extremen Steigungen - Sehr hohe Ansprüche an das fahrerische Können - Die Teilnahme an Wettkämpfen ist gestattet - Weite Sprünge und Drops sind zulässig (unter der Voraussetzung entsprechender Fahrtechnik) - Nicht für akrobatische Handlungen geeignet |

RANGE OF USE

| Symbol | Cycle category | Use |
|---|--|---|
|  | <p>Category 0 cycles are generally 12" balance bikes and 12" or 16" children's bikes.</p> | <p>CATEGORY 0:</p> <ul style="list-style-type: none"> - For children aged 3 years and up - Only for use under the supervision of a parent or guardian - Not permitted on the road - Not permitted in competitions - Not suitable for jumps or acrobatics |
|  | <p>Category 1 cycles are generally bikes, pedelecs and S-pedelecs in the style of racing bikes or fitness bikes (urban bikes).</p> | <p>CATEGORY 1:</p> <ul style="list-style-type: none"> - Solely for asphalt, concrete or paved roads and paths - Wheels must be kept in permanent contact with the ground - Permitted in competitions - Not suitable for drops, jumps or acrobatics |
|  | <p>Category 2 cycles are generally bikes, pedelecs and S-pedelecs in the style of city, trekking, cross-trekking or cargo bikes, as well as 20" children's bikes and 24" junior bikes.</p> | <p>CATEGORY 2:</p> <ul style="list-style-type: none"> - Includes category 1, plus surfaced and naturally firm paths with moderate inclines - Can be ridden down steps of up to 15 cm / 5.9", e.g. kerbs - Not permitted in competitions - Not suitable for jumps or acrobatics |
|  | <p>Category 3 cycles are generally bikes, pedelecs and S-pedelecs in the style of mountain bikes designed for cross-country, marathon and touring use, plus bikes in the cyclo-cross and all-track segments.</p> | <p>CATEGORY 3:</p> <ul style="list-style-type: none"> - Includes categories 1 and 2, plus rough trails with small obstacles, and unsurfaced routes that require good riding technique - Permitted in competitions - Drops and jumps permitted up to a max. height of 60 cm / 23.6" (with appropriate riding technique) - Not suitable for acrobatics |
|  | <p>Category 4 cycles are generally bikes, pedelecs and S-pedelecs in the style of mountain bikes designed for all-mountain use.</p> | <p>CATEGORY 4:</p> <ul style="list-style-type: none"> - Includes categories 1, 2 and 3 - Larger obstacles and higher speeds require increased riding skills - Permitted in competitions - Drops and jumps permitted up to a max. height of 120 cm / 47.2" (with appropriate riding technique) - Not suitable for acrobatics |
|  | <p>Category 5 cycles are generally bikes, pedelecs and S-pedelecs in the style of mountain bikes designed for enduro/freeride/downhill use.</p> | <p>CATEGORY 5:</p> <ul style="list-style-type: none"> - Includes categories 1, 2, 3 and 4, plus very fast and very demanding terrain with extreme inclines - Very high demands on riding skill - Permitted in competitions - Long drops and jumps permitted (with appropriate riding technique) - Not suitable for acrobatics |



IMPRINT

Alle Angaben der GHOST-Bikes GmbH wie Preise, Größen, Gewichte, Farben einschließlich Lieferzeiten und/oder sonstigen Angaben erfolgen mit größter Sorgfalt. Die GHOST-Bikes GmbH übernimmt keine Gewähr für mögliche Abweichungen. Offensichtliche Fehler oder Irrtümer im Katalog sind für die GHOST-Bikes GmbH nicht bindend. Alle Preise sind unverbindliche Preisempfehlungen inklusive der gesetzlichen MwSt.

Aus Gründen der besseren Lesbarkeit wird bei Personenbezeichnungen und personenbezogenen Hauptwörtern in diesem Dealerbook die männliche Form verwendet. Entsprechende Begriffe gelten im Sinne der Gleichbehandlung grundsätzlich für alle Geschlechter. Die verkürzte Sprachform hat nur redaktionelle Gründe und beinhaltet keine Wertung.

PHOTOS

Jens Staudt, Jan Kasl, Rob Trnka, Philip Ruopp, Christian Gaal, Felix Meyer, Adrian Greiter, Attention Builders, Yearning, GHOST Marketing

DANK AN

Alle Mitarbeiter von GHOST-Bikes – jeden Einzelnen in unserer einmaligen Firma, der ein Teil dieses langen und manchmal auch harten Entwicklungsprozesses unserer Produkte war, die wir nun mit Stolz präsentieren.

Irrtümer, Änderungen und Druckfehler vorbehalten.
Bilder können vom Original abweichen.

GHOST-Bikes GmbH ist ein Mitglied der ACCELL GROUP.

© 2022 GHOST Bikes

Unter Umständen sind nicht alle in diesem Katalog gezeigten Produkte in allen Regionen erhältlich, bitte kontaktiere dazu dein Vertriebsteam.

Weiterführende Informationen und Neuigkeiten findest Du unter www.ghost-bikes.com.

All representations made by GHOST-Bikes GmbH regarding numbers, sizes, weights, colours including delivery times and/or other specifications are made with care. GHOST-Bikes GmbH does not guarantee that there will not be any deviations. Obvious mistakes or errors in the catalogue are not binding on GHOST-Bikes GmbH. All prices are recommended retail prices incl. VAT.

For reasons of better readability, the masculine form is used for personal names and personal nouns in this dealerbook. Corresponding terms apply to all genders in the sense of equal treatment. The abbreviated language form has only editorial reasons and does not imply any valuation.

PHOTOS

Jens Staudt, Jan Kasl, Rob Trnka, Philip Ruopp, Christian Gaal, Felix Meyer, Adrian Greiter, Attention Builders, Yearning, GHOST Marketing

THANKS TO

All employees of GHOST-Bikes – to each one of you in our unique company who was a part of this long and sometimes difficult development process of our products which we now proudly present.

We are not liable for errors, changes or misprints.
Images might not represent the original.

GHOST-Bikes GmbH is a member of ACCELL GROUP.

© 2022 GHOST Bikes

Under certain circumstances, not all of the products shown in this catalogue might be available in all regions. Please contact your sales department for more information.

For more detailed information and other news, please visit our website at www.ghost-bikes.com.

GHOST-Bikes GmbH

An der Tongrube 3
95652 Waldsassen
Germany

Tel: +49 (9632) 9255-0
Fax: +49 (9632) 9255-116
Email: info@ghost-bikes.de
Web: ghost-bikes.com



GHOST

BUILT FOR THE ROUGH

Art. Nr.: KAT461



GHOST-BIKES.COM