

2013

GHOST[®]
GERMAN BICYCLE TECHNOLOGY



BIKEN BEDEUTET...

SEINE FREUDE MIT FREUNDEN ZU TEILEN

BIKING MEANS...SHARING FUN WITH FRIENDS



BIKEN BEDEUTET...

NEUE ORTE ZU ENTDECKEN

BIKING MEANS...DISCOVERING NEW PLACES









BIKEN BEDEUTET...

DIE NATUR ZU GENIESSEN

BIKING MEANS...ENJOYING NATURE

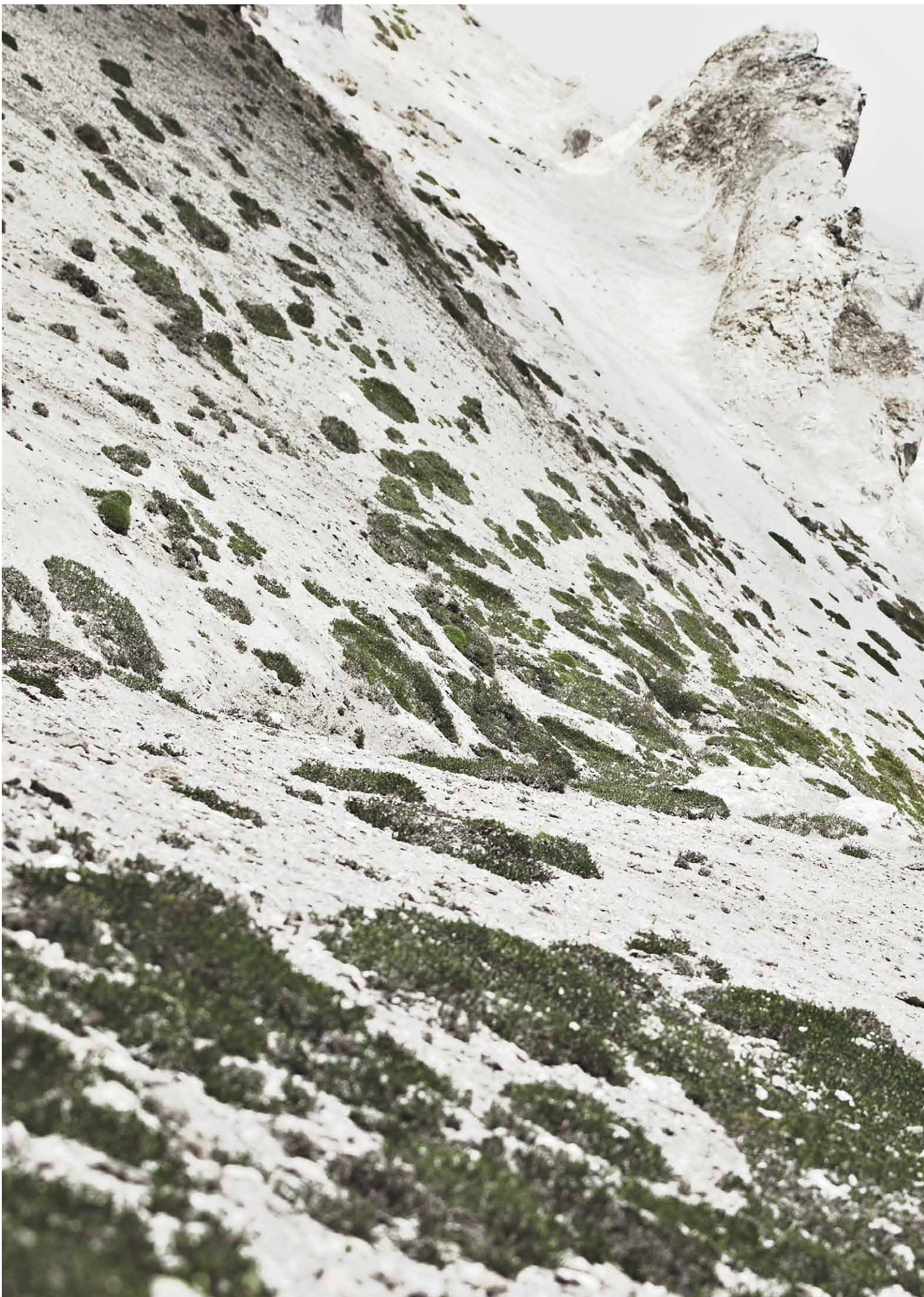

BIKEN BEDEUTET...

AUF DER SUCHE NACH SEINEN GRENZEN ZU SEIN

BIKING MEANS...SEARCHING FOR YOUR LIMITS





BIKEN BEDEUTET...

LEIDENSCHAFT!

BIKING MEANS...PASSION!

Philosophie, Leidenschaft und Begeisterung!

Das sind die Faktoren, die jeder Mitarbeiter bei GHOST in die Entwicklung der einzelnen Räder einbringt.

Die Wünsche der Kunden sowie die eigenen hohen Ansprüche sind unser Antrieb und lassen uns stetig nach wegweisenden Innovationen und Ideen streben.

Werde ein Teil dieser Leidenschaft - have your own GHOST.

Philosophy, passion and enthusiasm!

These characteristics are incorporated by each GHOST employee into the development of our bikes.

The demands of our customers and our own high goals drive us to constantly pursue trendsetting innovations and ideas.

Become a part of our passion - have your own GHOST.



20TH ANNIVERSARY





Auf der Suche nach dem perfekten Rad - 20 Jahre GHOST

Im Jahr 1993 sind wir zu einer langen Bike-Tour aufgebrochen. Wohin die Reise gehen sollte? Wie lange sie dauern sollte? Wir hatten damals keinen blassen Schimmer... Unser Gepäck: Ein Rucksack voll Leidenschaft, Liebe zur Technik, Natur und Umwelt, gepaart mit einer gehörigen Portion Experimentiergeist und Perfektionismus. Unsere Mission: Fahrräder der absoluten Spitzenklasse zu bauen. Wir sind einfach unserem Instinkt gefolgt und haben das getan, was wir am liebsten tun: Biken und Basteln, bei Tag und bei Nacht - bis auch das allerletzte Detail stimmt.

Zu zweit sind wir gestartet und über die Jahre gesellten sich immer mehr bike-euphorische Wegbegleiter dazu. Ohne sie wären wir nie da angekommen, wo wir gegenwärtig sind und in Zukunft hin wollen. Unseren Traum von damals haben wir unterwegs nie aus den Augen verloren: perfekte Räder für jeden Anspruch und Einsatzbereich zu entwickeln. Das schönste, sicherste und beste Rad für Profis, Genussradler und Freizeitathleten. Und das tun wir bis heute. Mit der gleichen Leidenschaft wie vor zwanzig Jahren. Für grenzenlosen Fahrspaß.

Looking for the perfect bicycle - 20 years of GHOST

In 1993 we started off on a lengthy bike tour. Where did we want to go? How long did we want to be on the road? We had no clue back then... Our luggage: A backpack full of passion, love for technology, nature and environment, combined with a healthy portion of ingenuity and perfectionism. Our mission: to build premium-class bicycles. We just followed our instinct and did what we loved to do: biking and tinkering, day and night - until the very last little detail was perfect.

We started off as just the two of us and over the years, we picked up more and more bike-crazy companions. Without them, we never would have gotten where we are now and where we want to go in the future. But we never lost sight of our dream from years ago: to build perfect bicycles for any standard and range of use. We wanted to create the safest, most beautiful, and best bike for professionals, joy riders and amateur athletes. And that's what we are still doing today. With the same passion we had twenty years ago. For infinite riding fun.

KLAUS MÖHWALD | GRÜNDER FOUNDER

GHOST 2013

INHALT | CONTENTS

<i>20TH ANNIVERSARY</i>	<i>14</i>
<i>ENTWICKLUNG DEVELOPMENT</i>	<i>18</i>
<i>TECHNOLOGIE TECHNOLOGY</i>	<i>20</i>
<i>DESIGN & PRODUKT MANAGEMENT DESIGN & PRODUCT MANAGEMENT</i>	<i>30</i>
<i>QUALITÄTSKONTROLLE QUALITY CONTROL</i>	<i>32</i>
<i>GHOST RACING TEAMS</i>	<i>34</i>
<i>GHOST BIKES 2013</i>	<i>38</i>
<i>20TH ANNIVERSARY SPECIAL</i>	<i>40</i>
<i>FULLY</i>	<i>44</i>
<i>AMR 29</i>	<i>48</i>
<i>AMR</i>	<i>52</i>
<i>ASX</i>	<i>58</i>
<i>AMR PLUS</i>	<i>62</i>
<i>CAGUA 650B</i>	<i>68</i>
<i>CAGUA</i>	<i>74</i>
<i>NORTHSHORE</i>	<i>80</i>
<i>DOWNHILL</i>	<i>84</i>
<i>HARDTAIL</i>	<i>90</i>
<i>HTX 29</i>	<i>94</i>
<i>HTX</i>	<i>98</i>
<i>SE 29</i>	<i>104</i>
<i>SE</i>	<i>110</i>
<i>DIRT 4CROSS</i>	<i>120</i>

<i>MISS</i>		126
	<i>MISS AMR</i>	128
	<i>MISS RT</i>	130
	<i>MISS</i>	131
<i>PEDELECS</i>		136
	<i>E-HYBRIDE TRAIL</i>	138
	<i>E-HYBRIDE CROSS</i>	142
	<i>E-HYBRIDE TREKKING E-HYBRIDE WAVE</i>	146
<i>TOWN & COUNTRY</i>		152
	<i>CROSS</i>	154
	<i>TREKKING</i>	164
<i>ROAD</i>		176
	<i>RACE</i>	178
	<i>SPEEDLINE</i>	186
<i>POWERKID</i>	<i>POWERKID POWERKIDDY</i>	192
<i>EBS</i>		206
<i>GEOMETRIE GEOMETRY</i>		214
<i>BEKLEIDUNG & ACCESSOIRES GEAR & APPAREL</i>		228
<i>TECH LEXIKON TECHNICAL DICTIONARY</i>		244
<i>ERGONOMIE ERGONOMICS</i>		248
<i>MITARBEITER STAFF</i>		250
<i>GHOST INTERNATIONAL</i>		252
<i>IMPRESSUM</i>		254

GHOST ENTWICKLUNG

GHOST DEVELOPMENT

„Leidenschaft, Faszination und Pioniergeist - drei zentrale Begriffe, die für unsere Entwicklungen bei GHOST stehen. Mein Ziel ist es, Fahrräder zu entwickeln, die technisch und optisch nicht nur dem Zeitgeist entsprechen, sondern Teil der nächsten Evolutionsstufe sind. Bikes der neuen Generation.“

„Passion, fascination and pioneering spirit - three central terms, which represent our innovations at GHOST. My goal is to develop bicycles which not only represent the current technical and design zeitgeist, but are part of the next step of evolution. Bikes for a new generation.“

VOLKER ACKERMANN | SENIOR ENGINEER

German Bicycle Technology

Bei GHOST setzen wir auf die Fähigkeiten unseres Entwicklungsteams mit top ausgebildeten Ingenieuren, Technikern und Designern - Biker mit Leib und Seele. Unsere sehr erfolgreichen Teamfahrer geben mit ihren Erfahrungen aus dem harten Rennbetrieb wichtige Impulse für Neuentwicklungen und tragen zur steten Verbesserung der Räder bei.

Mittels modernster CAD-Software und Berechnungstools entstehen unsere Hightech-Fahrräder am Standort Waldsassen in Bayern. In enger Zusammenarbeit mit unseren kompetenten Entwicklungspartnern, allen voran die Technische Universität Chemnitz, entstehen innovative Lösungsansätze. So setzen wir in unseren Rädern bereits heute die Technologien von morgen ein.

Weil unser Designteam mit den Entwicklern von A bis Z Hand in Hand arbeitet, entstehen Fahrräder in perfekter Form und Funktion.

At GHOST we highly value the skills of our development team consisting of top-educated engineers, technicians and designers - bikers with heart and soul. Our very successful team riders and their experience in the tough racing scene give important input into new developments and contribute to the continuous improvement of our bicycles.

Our high-tech bicycles are built with the aid of the latest CAD software and calculation tools at our Waldsassen location in Bavaria. Our close cooperation with competent development partners, most importantly the Technical University in Chemnitz, results in innovative solution concepts. We are able to incorporate tomorrow's technologies into today's bicycles.

Since our design team is working closely with our developers every step of the way, we develop bicycles with perfect form and function.

ENTWICKLUNGSPARTNER
DEVELOPMENT PARTNER



TECHNISCHE UNIVERSITÄT
CHEMNITZ



silbærg
SNOWBOARDS





E:i SHOCK

MULTIFUNKTIONS-
ANZEIGE

MULTIINFORMATION
DISPLAY

AUTOMATISCHE
DÄMPFEREINSTELLUNG
AUTOMATIC SHOCK ADJUSTMENT

LEISTUNGSFÄHIGER
AKKU

POWERFUL BATTERY

INTELLIGENTER COMPUTER

INTELLIGENT COMPUTER

TRETLAGERSENSOR

BOTTOM BRACKET SENSOR



Erstmalig passt sich dein Hinterraddämpfer an jeden Fahrzustand selbstständig an. Vortrieb, Traktion und Komfort schließen sich endlich nicht mehr gegenseitig aus, sondern werden in jeder Fahrsituation ohne Kompromisse umgesetzt.

For the first time, your rear suspension adjusts automatically to all riding conditions. Propulsion, traction and comfort no longer compete with each other. Now your bicycle provides all you need without any compromise.

FEDERGABEL-SENSOREN

SUSPENSION FORK SENSORS

FEDERGABELSENSOREN

SUSPENSION FORK SENSORS

Zwei Sensoren bestimmen anhand der Gabel-Beschleunigung, welche Dämpfer Position optimal ist.

Two sensors determine the perfect E:| Shock position by measuring fork acceleration

TRETLAGERSENSOR

BOTTOM BRACKET SENSOR

Er liefert die Information ob getreten wird, oder nicht.

Senses crank rotation and transmits status to the computer

INTELLIGENTER COMPUTER

INTELLIGENT COMPUTER

Der Computer verarbeitet alle Daten und gibt die richtige Einstellungen an den Dämpfer weiter.

Computes all data and transmits the perfect settings to the E:| Shock

MULTIFUNKTIONSANZEIGE

MULTI-FUNKTIONAL DISPLAY

Das Display vereint die umfangreichen Funktionen eines hochwertigen Tachometers mit der Statusanzeige des E:| Shock Systems.

The display combines ample functions of a high-quality tachometer with the status display of the E:| Shock system.

AUTOMATISCHE DÄMPFEREINSTELLUNG

AUTOMATIC SHOCK ADJUSTMENT

- (1) Open wenn nicht getreten wird und bei großen Schlägen
when no active pedaling takes place and during large impacts
- (2) Platform sobald getreten wird und der Boden ungleichmäßig ist
as soon as pedaling takes place and terrain is uneven
- (3) Lock sobald getreten wird und der Boden eben ist
as soon as pedaling takes place and terrain is even

LEISTUNGSFÄHIGER AKKU

POWERFUL BATTERY

Ein leistungsfähiger Akku stellt die Energie für langanhaltenden Fahrspaß zur Verfügung.

A powerful battery provides the energy for long-lasting riding fun.



CAGUA 650B

ANTI SQUAT

X-12

ISCG

E-TYPE DIRECT

PRESSFIT BB



E-TYPE DIRECT

Bei dieser Technologie wird der vordere Umwerfer direkt an den Rahmen geschraubt. Rahmen belastende Schellenlösungen gehören damit der Vergangenheit an. Durch diese Systemintegration werden unsere Rahmen noch leichter. Aber auch bei der Performance wirst du eine deutliche Verbesserung spüren. Der Umwerfer steht dank hochpräziser Fertigung immer perfekt zum Kettenblatt. Knackige und äußerst präzise Schaltvorgänge sorgen somit für noch mehr Fahrspaß.

This technology means that the front derailleur is screwed directly onto the frame. Frame stressing shell mounting solutions are a thing of the past. The result of this system integration is another improvement yielding even lighter frames. In addition, you will also notice significantly improved performance. Thanks to the ultra-precise manufacturing process the derailleur is always perfectly located in relation to the chain ring. Crisp and supremely precise gear shifting provides even more riding fun.

PBB PRESSFIT BB

Bei PressFit Innenlagern werden die Lagerschalen direkt in das Tretlagergehäuse eingepresst und nicht wie üblich geschraubt. Die größere Gehäusebreite erlaubt es, das Unterrohr breiter anzubinden. Die größere Abstützbreite erhöht die Steifigkeit und die fehlende Verschraubung erhöht die Stabilität und reduziert den Wartungsaufwand.

PressFit Bottom Brackets feature bearing shells that are directly pressed - and not screwed - into the bottom bracket housing. The larger housing width allows for a wider down tube. Greater support width results in increased stiffness. The screwless design improves stability and reduces maintenance.

X12

Mit dem X-12 Steckachs-System wird der Einsatz von Steckachsen für ein größeres Bikespektrum sinnvoll. Denn das Syntace X-12 System ist leicht und dabei supersteif, die Nabenachse wird unter hoher Axialspannung bombenfest in den Hinterbau geklemmt.

Thanks to the X-12 rear-axle standard, it makes sense to use a through-axle system on a wider spectrum of bicycles. The Syntace X-12 system is light and yet super stiff because the hub axle is clamped tightly into the rear triangle under great axial tension.

ISCG

Die ISCG-Aufnahmen finden sich an unseren 4Cross und DH-Rahmen. Der International Standard for Chain Guide ist eine genormte 3-Punkt-Befestigung von Kettenführungen am Tretlagergehäuse. Vorteil: Bei der Montage von Kettenführungen muss das Tretlager nicht ein- oder ausgebaut werden.

Our 4-Cross and DH frames are ISCG compatible. The International Standard Chain Guide is a standardized 3-point mounting system to mount chain guides to bottom bracket shells. The advantage: Mounting chain guides does not require disassembly and reassembly of the bottom bracket.

ANTI-SQUAT TECHNOLOGY

Durch geschickte Positionierung der Drehpunkte in unserem Hinterbau federt dieser beim Pedalieren nicht ein (Anti Squat Effekt) und liefert damit eine effektive Kraftübertragung ohne störendes Wippen. Die Traktion wird verbessert und negative Fahrwerkseinflüsse werden eliminiert.

Clever positioning of the rear triangle pivot points eliminates squatting during pedaling (anti-squat effect) and offers efficient power transmission without unwanted bobbing. Traction is improved and negative forces are eliminated.

HTX LECTOR 29

MIMS

ACTIVE FLEX
SEAT STAY

SPECIFIC CHAINSTAY LENGTH



TAPERED HEADTUBE



THT | TAPERED HEAD TUBE

Das Tapered Steuerrohr wird nach unten hin breiter, wodurch die Kräfte von der Gabel besser in den Rahmen eingeleitet werden. Durch die erhöhte Steifigkeit des THT zusammen mit der Tapered Gabel erhält das Bike ein besseres, direkteres Lenkverhalten.

The tapered head tube broadens towards the bottom leading to better force transfer from the fork to the frame. The increased stiffness of the tapered head tube combined with the tapered fork lead to the bicycle's improved and more direct steering.

ACTIVE FLEX SEAT STAY

Die flexenden Sitzstreben bieten ein gewisses Maß an vertikaler Nachgiebigkeit und damit die entscheidende Schonung, die der Körper braucht. Jede Erschütterung, die der Rahmen aufnehmen kann, schont die Muskulatur des Fahrers.

Flexing seat stays offer a certain amount of vertical give and therefore offer crucial protection the body needs. Each vibration and shock the frame can absorb spares the rider's muscles unnecessary strain.

MIMS

Bei unseren Lector Modellen wenden wir sowohl das Lug Bonding und T2T Verfahren als auch die Monocoque Bauweise an. Dabei vereinen wir die Vorteile aus jedem Verfahren - bei bestem Preis-Leistungsverhältnis

Our HTX models are manufactured by combining the advantages of the Lug Bonding, T2T and Monocoque processes resulting in an optimum price to performance ratio.

SCL SPECIFIC CHAINSTAY LENGTH

Specific Chainstay Length, also mit der Rahmengröße mitwachsende Kettenstreben, haben bei uns schon eine lange Tradition. Das Prinzip ist einfach: Unsere Rahmen wachsen nicht nur am Vorderrahmen in Höhe und Länge, sondern auch am Hinterbau im gleichen Verhältnis. Das Ergebnis ist ein perfekt ausbalanciertes Bike, das in jeder Rahmenhöhe gleichbleibend überragende Fahreigenschaften bietet.

Specific Chainstay Length means that the chainstays grow with frame size. This system already has a long tradition at GHOST. The principle is easy. Not only do our frames grow in height and in length at the front, but also at the chainstay at exactly the same ratio. This results in a perfectly balanced bike which offers superior riding performance in any frame size.

E-HYBRIDE

CONTINUOUS
CABLE HOUSING

BOSCH SYSTEM

HYDROFORMING TUBESET



In den neuen E-Hybride-Serien Cross, Trekking und Wave setzen wir das bewährte BOSCH Mittelmotor-System ein. Mit seiner intelligenten 3-fach-Sensorik sorgt der Pedelec-Antrieb für unaufdringlichen Schub, der Fahrspaß, Leichtigkeit und Beherrschbarkeit garantiert. Dabei lässt sich die Unterstützung in mehreren Stufen einstellen oder bei Bedarf deaktivieren. Moderne Lithium-Ionen-Akkus sorgen mit einem Energiegehalt von bis zu 400 Wattstunden für hohe Reichweiten und langanhaltenden Fahrspaß. Das mitgelieferte Schnellladegerät ermöglicht eine vollständige Aufladung der herausnehmbaren Akkus in weniger als 3,5 Stunden.

Our new E-Hybride series Cross, Trekking and Wave feature the proven BOSCH middle motor system. Thanks to its intelligent three-way sensor technology, the pedelec drive provides discreet power, which guarantees riding fun, lightness and control. There are several assist levels to choose from, and the assist can also be switched off entirely. Modern Lithium-Ion batteries provide energy supply of up to 400 watt-hours for long range and long-lasting riding fun. The charger, which is included, is capable of a complete recharge of the detachable battery in less than 3.5 hours.



Die Schaltzüge sind mit durchgehenden Außenhüllen ausgestattet. Dies garantiert auch langfristig gute Schaltperformance, weil die Schaltqualität nicht durch Verschmutzung und Nässe in den Zügen beeinflusst wird.

The derailleur cables have continuous cable housings. Great long-term shift performance is guaranteed by eliminating any negative effects dirt might cause in the derailleur cables.



Das optisch markante Erscheinungsbild macht unsere Aluminiumrahmen mit dieser Technologie nicht nur zu einem echten Hingucker. Durch die bedarfsgerechte, optimale Anpassung der Rohrform an die einwirkenden Kräfte wird das Rad trotz niedrigerem Gewicht noch stabiler.

We do not use standardized tubesets, but develop our frames and required tubes ourselves. A lightweight, yet sturdy frame requires specifically adapted forms and wall thicknesses.

GHOST TECHNOLOGIE

GHOST TECHNOLOGY

ION TECHNOLOGY

Unsere E-Hybride-Trail-Modelle begeistern seit 2012 mit dem kraftvollen ION-Hinterradantrieb. Der lautlose Direktantrieb sorgt in Verbindung mit einer ausgeklügelten Steuerung und Sensorik für ein äußerst natürliches Fahrgefühl. Eine hervorragende Gewichtverteilung ist die Folge des im Unterrohr integrierten Akkus, der bestens gegen Beschädigungen geschützt wird und unsere E-Hybride-Trail-Modelle erst auf den zweiten Blick als Pedelecs erkennen lässt.

Neu bei den 2013er Modellen ist ein Display, welches neben umfangreichen Funktionen die Möglichkeit bietet, dem Akku beim Bergabfahren Energie zurückzuführen und damit die Reichweite und Fahrfreude zu verlängern.

Our E-Hybride Trail models, introduced in 2012, wow with their powerful ION rear wheel drive. In combination with thought-out control and sensor technology, the silent direct drive provides an extremely natural riding feel. The battery is integrated into the downtube where it is optimally protected against damage and makes our E-Hybride Trail models hard to identify as Pedelecs. It also yields another huge advantage: excellent weight balance.

New for 2013 is a display which features multiple functions and the opportunity to recharge the battery on the downhill which increases range and prolongs riding fun.



Durch den im Unterrohr integrierten Akku entstehen mehrere Vorteile. Der Schwerpunkt des Rades ist tief und zentral gelegen, was ein angenehm sicheres Fahrgefühl auch bei höheren Geschwindigkeiten mit sich bringt. Zudem sorgt diese "Aluminiumhülle" um den Akkupack für einen zusätzlichen Schutz vor Beschädigungen. Auch optisch ist die Integration des Akkus im Unterrohr eine besonders schöne Lösung. Alle Kabel sind perfekt integriert und garantieren so für ein aufgeräumtes Erscheinungsbild. Im Bedarfsfall kann der Akku mit wenigen Handgriffen ausgebaut werden.

The integration of the battery into the down tube yields several advantages. The center of gravity of the bicycle is low and central which ensures a pleasantly safe riding feeling even at higher speeds. In addition, the "aluminum sleeve" around the battery pack provides additional protection from the elements. Visually, the integration of the battery in the down tube is an especially beautiful solution as well. All cables are perfectly integrated and guarantee a clean appearance. If necessary, the battery can be easily removed.

SMOOTH RATIO SUSPENSION 2:1

Der Rocker lenkt mit einem Übersetzungsverhältnis von 2:1 den Dämpfer an. Das bedeutet, dass sich der Dämpfer für 2 cm Federweg am Hinterbau genau 1 cm bewegt. Das Ergebnis spürst du sofort. Die Federung arbeitet deutlich sensibler und lässt sich auch einfacher abstimmen. Zudem sind die auftretenden Reibungskräfte geringer, da der Dämpfer mit weniger Luftdruck gefahren werden kann. Das sorgt neben der immens verbesserten Sensibilität auch für eine längere Lebensdauer.

The rocker activates the shock with a transmission ratio of 2:1. This means that the suspension element moves by 1 cm for 2 cm of travel at the chainstay. You'll notice the result immediately. The suspension operates noticeably more sensitively and is much easier to tune. In addition, the operating friction forces are much lower because the damper requires less air pressure. In addition to the immensely improved sensitivity, this also ensures more durability.



Unser Needle Bearing System steht für super sensibel ansprechende Hinterbauten. Viele Testergebnisse belegen dies eindrucksvoll. Die Technik ist gleichermaßen einfach wie genial. Die Nadellager befinden sich im Dämpferauge an Stelle der herkömmlich eingesetzten Gleitlager und sorgen so für ein minimales Losbrechmoment. Das Ergebnis ist ein überragendes Ansprechverhalten schon bei kleinsten Fahrbahnunebenheiten.

Our Needle Bearing System ensures super sensitive rear triangle performance, as many test results have impressively shown. The technology is both simple and ingenious. The needle bearings are located in the damper eyelet, replacing commonly used bush bearings, and ensure a minimum break-away torque. The low torque results in an outstanding responsiveness to even the smallest bumps.

PM DIRECT

Der Verzicht auf unnötige Schrauben und die vereinfachte Einstellbarkeit machen PM Direct zum neuen Standard. Die direkte Aufnahme des Bremssattels sorgt für cleane Optik und ideale Wärmeableitung.

PM Direct's screwless design and simplified adjustability has become the new standard. Mounting the brake caliper directly onto the post results in a clean look and optimum heat transfer.

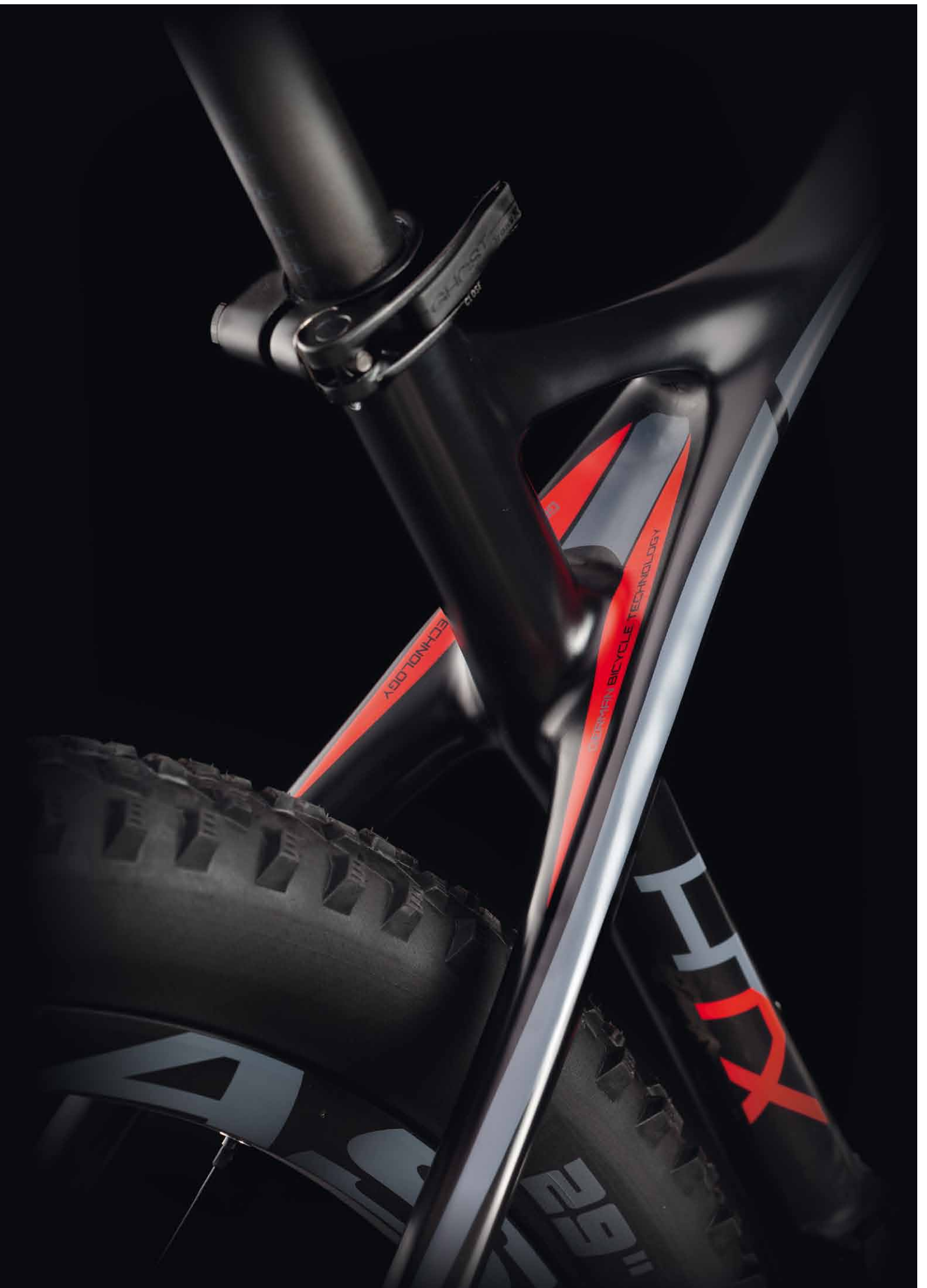

GHOST DESIGN & PRODUKTMANAGEMENT

GHOST DESIGN & PRODUCT MANAGEMENT

„Höchste Qualität an unseren Bikes, sei es bei Gabel, Schaltung oder Dämpfer, zu einem fairen Preis für unsere Kunden, das ist mein oberstes Ziel. Technische Innovationen und die Weiterentwicklung bewährter Produkte faszinieren mich und werden persönlich auf ausgiebigen Touren unter die Lupe genommen. Die Leidenschaft zum Biken treibt mich an, für jede Alters- und Zielgruppe das perfekte Fahrrad auf den Markt zu bringen.“

„My ultimate goal is to offer highest possible bicycle quality, including fork, rear derailleur and suspension system at a fair price for our customers. Technical innovations and redesign of proven products fascinate me and I am testing them myself extensively on extended tours. My passion for cycling is what drives me - to introduce the perfect bicycle for every age and target group to the market.“

FLORIAN ZEITLER | PRODUCT MANAGER

Im Jahr 2011 erhielten unsere rennerprobten Modelle HTX Lector Pro Team und RT Lector Pro Team den begehrten Red Dot Design Award in der hartumkämpften Kategorie Product Design. Weiterhin erhielt das HTX Lector 5800 den Focus Open Award in Silber.

Auch im Jahr 2012 beeindruckt unser neues Modell HTX 29 Lector mit dem internationalen Taipei Cycle D&I Award sowie das Cagua Lector mit dem Universal Design Award 2012. Wir freuen uns über diese Auszeichnungen, weil sie zeigen, dass Funktionalität, Ergonomie und zukunftsweisendes Design in unseren Fahrrädern erfolgreich umgesetzt wird. Schließlich profitieren unsere Modelle aus dem Modelljahr 2013 von den Erfolgen und wir sind entschlossen auch in Zukunft Fahrräder mit modernem Design und innovativer Technik anzubieten.

In 2011 our race-proven models HTX Lector Team Pro and RT Lector Pro team won the coveted Red Dot Design Award in the highly competitive category product design. Furthermore, the HTX Lector 5800 received the Focus Open Award in silver.

Also in 2012, our new model HTX Lector 29 impresses with the international Taipei Cycle D&I award and the Cagua Lector with the Universal Design Award. We are pleased to receive these awards. It shows that functionality, ergonomics and innovative design are successfully implemented in our bikes. Finally, our 2013 models will benefit from the successes and we are determined to offer bikes with modern design and innovative technology in the future.



HTX Lector 2011
RT Lector 2011



HTX Lector 29 2013



Cagua Lector 2012



HTX Lector 2011



GHOST QUALITÄTSKONTROLLE

GHOST QUALITY CONTROL

„Die Liebe zum Fahrrad ist mein täglicher Antrieb, die Bikes noch sicherer und besser zu machen. Ich teste die Bikes nicht nur im Labor, sondern auch draußen auf den Trails persönlich auf Herz und Nieren. Und nur, wenn es mich überzeugt, geht es mit der Weiterentwicklung weiter. Ich stehe im engen Kontakt mit der Entwicklungsabteilung und den Rennteams. Zusammen optimieren wir die Bikes bis ins kleinste Detail.“

„Love of cycling drives me daily to make our bikes even safer and better. I test the bicycles not only in the lab, but also put them through the acid test outdoors on the trails. The development process only continues when I am convinced. I am in very close contact with the development department and the racing teams. Together, we optimize the bikes down to the last little detail.“

TINO BUSCHMANN | QUALITY ENGINEER

Die Sicherheit unserer Kunden ist eine zentrale Säule in der GHOST Philosophie. Deshalb testen wir unsere Rahmen noch härter und präziser, als es die europäische Norm vorschreibt. Jede Radkategorie wird dem Einsatzbereich entsprechend getestet. In Entwicklungsprojekten mit der Technischen Universität Chemnitz und der Technischen Universität München wurde ermittelt, welche realen Kräfte bei intensivem Fahrbetrieb auf unsere Rahmen einwirken.

Moderne Prüfstände stellen den realen Fahrbetrieb nach, so dass man ein ganzes Fahrradleben im Zeitraffer simulieren kann. Auf diese Weise werden Prototypenkonstruktionen bis zur Serienreife optimiert und weiterentwickelt. Darüber hinaus sind auch die Erkenntnisse unserer Zulieferer und externer Prüfinstitute sowie regelmäßige Kontrollen in der Serienfertigung unerlässlich, um die hohen Qualitätsansprüche an ein GHOST Bike zu erfüllen. Auch die Anbauteile unserer Bikes müssen dem europäischen Standard für Fahrradteile (CEN-Norm) entsprechen und sind nach dieser Norm zertifiziert.

Our customers' safety is a central pillar of GHOST's philosophy. That is why we put our frames through tougher and more precise tests than required by European standards. Each bicycle category is tested according to its intended range of use. Developmental research projects at the Technical University Chemnitz and the Technical University of Munich determine the specific real forces which our frames have to sustain during intense riding conditions.

The latest test rigs simulate real riding conditions and enable us to compress a bike's entire life cycle into a short amount of time. This is how new prototype designs are optimized and redesigned until they reach serial production readiness. In addition, the findings of our suppliers, external testing centers and regular production checks are essential for GHOST bicycles to fulfill the highest quality demands. The components of our bicycles also have to meet the European standard (CEN standard) for bicycle components and are certified according to this standard.



GHOST RACING TEAMS

CROSS COUNTRY

GHOST FACTORY RACING TEAM

Neben aufwendigen Labortests leisten die Profis des GHOST Factory Racing Teams mit ihren Praxis-Feedbacks einen wichtigen Beitrag zur stetigen Weiterentwicklung der hochwertigen GHOST Rahmen.

Nicht ohne Grund stehen die GHOST Athleten mit ihren Bikes immer wieder auf den Podien dieser Welt: Olympia-Gold, Weltcup-Siege, WM-Medaillen, EM-Titel, unzählige DM-Titel und Bundesliga-Gesamtsiege. Sicherlich werden diese Leistungsträger auch in der kommenden Saison ihre Erfolgsgeschichte fortschreiben. Die GHOST Family drückt euch allen die Daumen und wünscht euch viel Glück und Erfolg.

In addition to extensive lab tests, the practical feedback of the GHOST Factory Team professionals is a crucial contribution to the continuous further development of premium-quality GHOST frames.

GHOST athletes and their bicycles can be seen on podiums all over the world again and again for a reason: Olympic Gold, World Cup victories, World Championship medals, European Championship medals, countless German Championship titles and German Federal League Overall victories. Surely, these top performers will add to their success stories during the upcoming season. The GHOST family keeps their fingers crossed and wishes you all the best, good luck and great results.





GHOST RACING TEAMS

ROAD

NSP GHOST TEAM

Das NSP GHOST Team hat sich aus dem GHOST Junior Road Team weiterentwickelt und konnte bereits in den ersten beiden Saisons beeindruckende Erfolge in der Profi-Liga einfahren.

NSP GHOST Team evolved from the GHOST Junior Road Team and was able to achieve impressive results in their first two seasons in the professional league.

GRAVITY

GHOST FACTORY RACING TEAM

Against the Gravity - das Spiel mit der Schwerkraft.

Egal ob Downhill Weltcup, 4X World Series, Rampage oder Enduro - die härtesten Prüfstände dieser Welt befinden sich auf den Rennstrecken rund um den Globus. Mit dabei die schnellsten Mountainbiker Deutschlands. Die Fahrer des GHOST Factory Racing Teams treiben dabei die Entwicklung der Bikes von morgen voran. GHOST Bikes - von der Rennstrecke direkt zu dir nach Hause.

Whether it is Downhill World Cups, 4X World Series, rampage or Enduro - the toughest test rigs in the world are the race courses around the globe. And Germany's fastest mountain bikers are right there. The GHOST Factory Racing Team riders drive the development of tomorrow's bikes. GHOST Bikes - from the race course straight to your house.





GHOST BIKES 2013

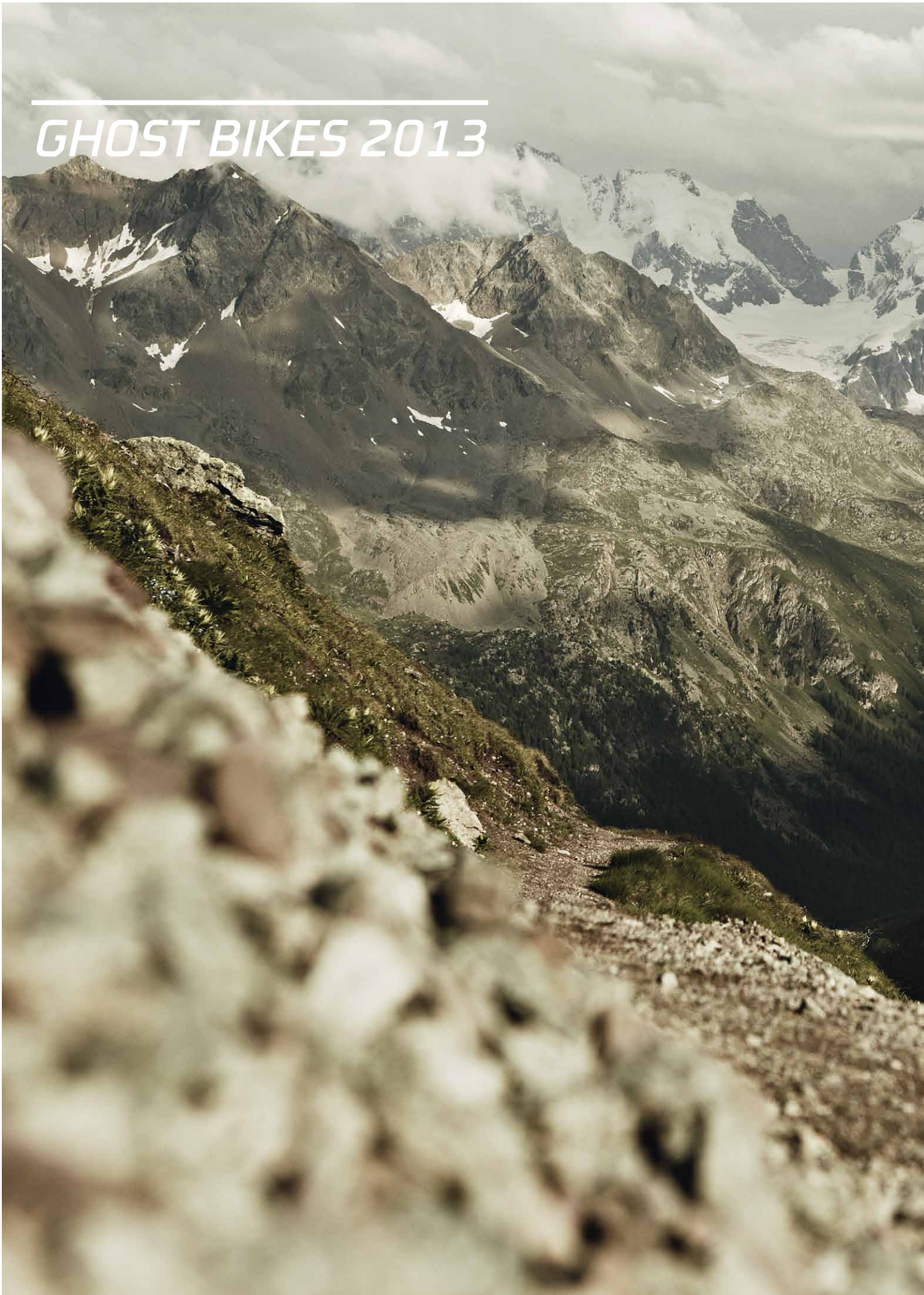

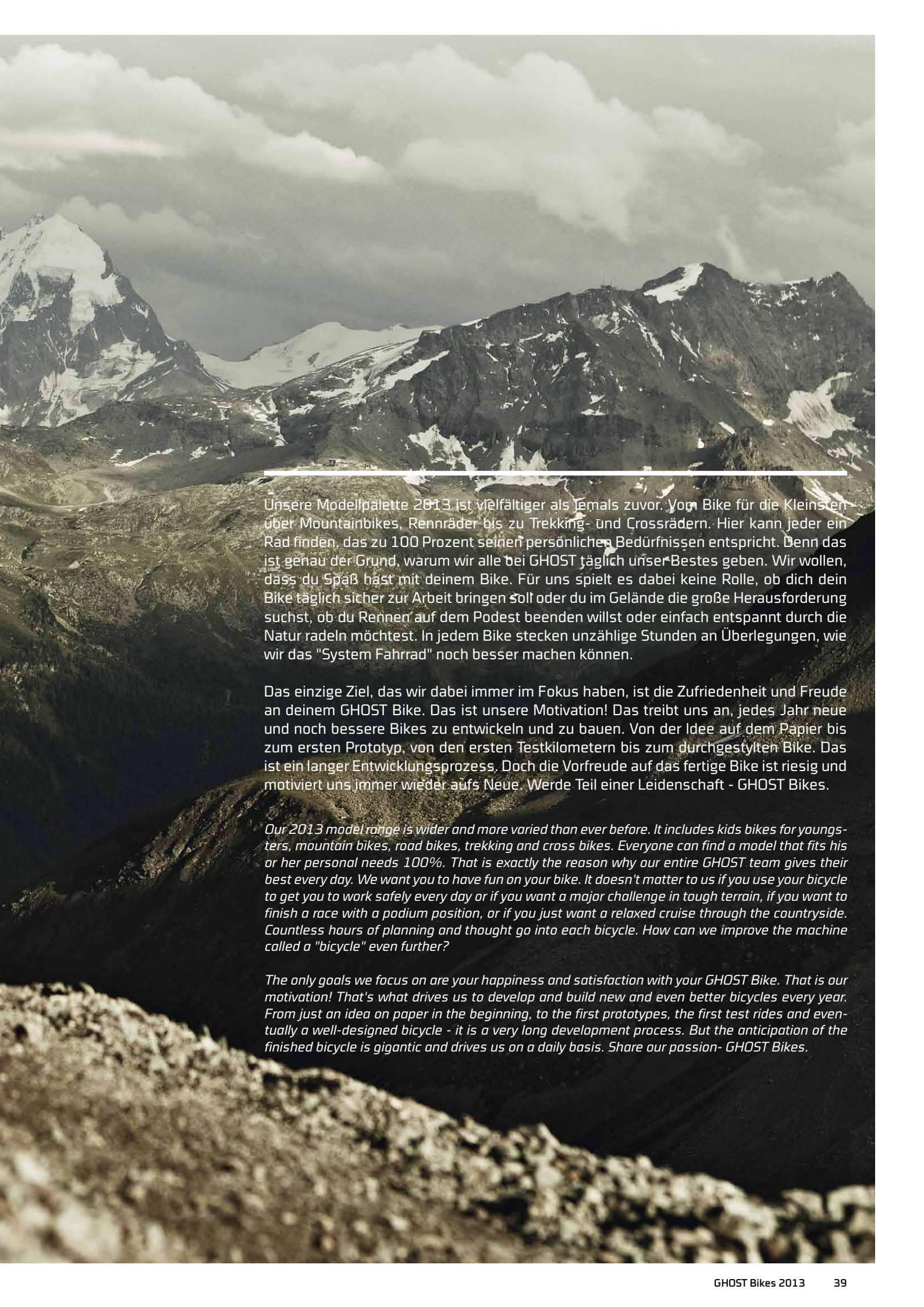

Unsere Modellpalette 2013 ist vielfältiger als jemals zuvor. Vom Bike für die Kleinsten über Mountainbikes, Rennräder bis zu Trekking- und Crossrädern. Hier kann jeder ein Rad finden, das zu 100 Prozent seinen persönlichen Bedürfnissen entspricht. Denn das ist genau der Grund, warum wir alle bei GHOST täglich unser Bestes geben. Wir wollen, dass du Spaß hast mit deinem Bike. Für uns spielt es dabei keine Rolle, ob dich dein Bike täglich sicher zur Arbeit bringen soll oder du im Gelände die große Herausforderung suchst, ob du Rennen auf dem Podest beenden willst oder einfach entspannt durch die Natur radeln möchtest. In jedem Bike stecken unzählige Stunden an Überlegungen, wie wir das "System Fahrrad" noch besser machen können.

Das einzige Ziel, das wir dabei immer im Fokus haben, ist die Zufriedenheit und Freude an deinem GHOST Bike. Das ist unsere Motivation! Das treibt uns an, jedes Jahr neue und noch bessere Bikes zu entwickeln und zu bauen. Von der Idee auf dem Papier bis zum ersten Prototyp, von den ersten Testkilometern bis zum durchgestylten Bike. Das ist ein langer Entwicklungsprozess. Doch die Vorfreude auf das fertige Bike ist riesig und motiviert uns immer wieder aufs Neue. Werde Teil einer Leidenschaft - GHOST Bikes.

Our 2013 model range is wider and more varied than ever before. It includes kids bikes for youngsters, mountain bikes, road bikes, trekking and cross bikes. Everyone can find a model that fits his or her personal needs 100%. That is exactly the reason why our entire GHOST team gives their best every day. We want you to have fun on your bike. It doesn't matter to us if you use your bicycle to get you to work safely every day or if you want a major challenge in tough terrain, if you want to finish a race with a podium position, or if you just want a relaxed cruise through the countryside. Countless hours of planning and thought go into each bicycle. How can we improve the machine called a "bicycle" even further?

The only goals we focus on are your happiness and satisfaction with your GHOST Bike. That is our motivation! That's what drives us to develop and build new and even better bicycles every year. From just an idea on paper in the beginning, to the first prototypes, the first test rides and eventually a well-designed bicycle - it is a very long development process. But the anticipation of the finished bicycle is gigantic and drives us on a daily basis. Share our passion- GHOST Bikes.

AMR LECTOR 20TH ANNIVERSARY

GREY / BLACK / RED



Im Jahr 1993 sind wir zu einer langen Bike-Tour aufgebrochen. Wohin die Reise gehen sollte? Wie lange sie dauern sollte? Mit unserem AMR für immer...

In 1993, we started off on a lengthy bike tour. Where did we want to go? How long did we want to be on the road? With our AMR, forever...

SMOOTH RATIO
SUSPENSION **2:1**

SCL SPECIFIC
CHAINSTAY LENGTH

ANTI-SQUAT
TECHNOLOGY

20
years

	AMR HM Carbon/Alloy MIMS SCL		Shimano 505 Disc 180 mm
	GHOST light A5-007N 31.8 mm		Schwalbe Nobby Nic 2.25
	Rock Shox Reba RL Solo Air PopLoc 120 mm Tapered		Schwalbe Nobby Nic 2.25
	Ritchey Tapered		Alex DP 20 Disc
	GHOST Low Rizer light 680 mm 31.8 mm		DT Swiss 1.8
	GHOST SL SP 717 31.6 mm		Shimano 435
	GHOST VL 1535		Shimano CS-HG62 11-34
	Shimano XT 10-Speed		SRAM Monarch RT 3
	Shimano SLX		120 mm
	Shimano Deore SL		120 mm
	Shimano 505		40/44/48/52/56 cm
	Shimano Pressfit BB		kg
	Shimano SLX 42-32-24		12.40 kg

HTX LECTOR

20TH ANNIVERSARY

BLACK / GREY / RED



- | | | | |
|--|-------------------------|----------------------------|-------------------|
| HTX HM Carbon MIMS AFT SCL | Shimano XT 10-Speed | Schwalbe Racing Ralph 2.25 | 100 mm |
| GHOST light AS-007N 31.8 mm | Shimano SLX | Schwalbe Racing Ralph 2.25 | 40/44/48/52/56 cm |
| Rock Shox Reba RL Solo Air PopLoc 100 mm Tapered | Shimano Deore SL | Alex XD Sport | 10.70 kg |
| Ritchey Tapered | Shimano 505 | DT Swiss 1.8 | |
| GHOST Low Rizer light 660 mm 31.8 mm | Shimano Pressfit BB | Shimano Deore | |
| GHOST SL SP 717 27.2 mm | Shimano XT 42-32-24 | SRAM PG-1030 11-36 | |
| GHOST VL 1535 | Shimano 505 Disc 180 mm | | |

RACE LECTOR

20TH ANNIVERSARY

BLACK / GREY / RED



- | | | | |
|-------------------------------|-------------------------------|----------------------|-------------------|
| Race HM Carbon ACR SCL | Shimano Ultegra 10-Speed | Schwalbe Ultrero | 100 mm |
| FSA 190 Laser 31.8 mm | Shimano Ultegra | Schwalbe Ultrero | 47/50/53/56/59 cm |
| CG Carbon | Shimano Ultegra | Easton 700C Wheelset | 7.60 kg |
| Tapered | Shimano Ultegra | Easton 700C Wheelset | |
| FSA Road Vero Compact 31.8 mm | Shimano Pressfit BB | Easton 700C Wheelset | |
| GHOST SL SP 717 27.2 mm | Shimano Ultegra Compact 50-34 | Shimano 105 11-28 | |
| GHOST VL 1411 | Shimano Ultegra | | |



20 YEARS

FULLY

AMR 29

Marathon Race



All Mountain Tour



AMR

All Mountain Tour

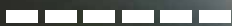

All Mountain Trail



ASX

All Mountain Tour



AMR PLUS

All Mountain Tour

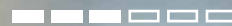

All Mountain Trail

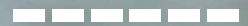



CAGUA 650B

All Mountain Trail

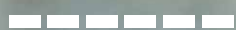

Enduro

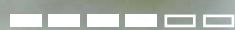

CAGUA

Enduro

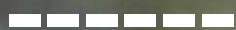

Freeride

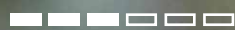

NORTHSHORE

Freeride

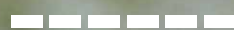

Downhill

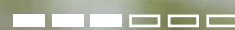

DOWNHILL

Downhill

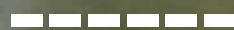

Freeride



AMR

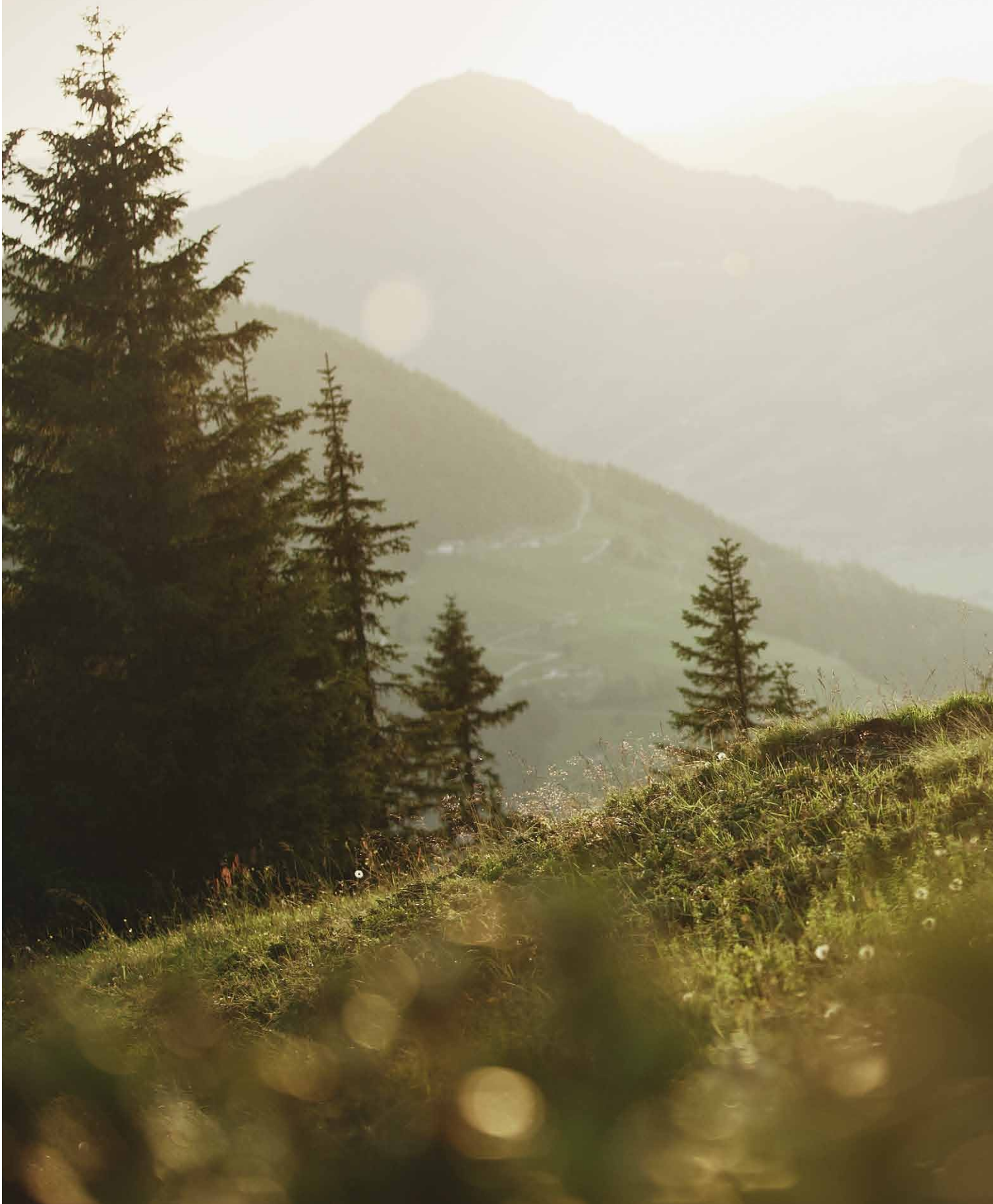

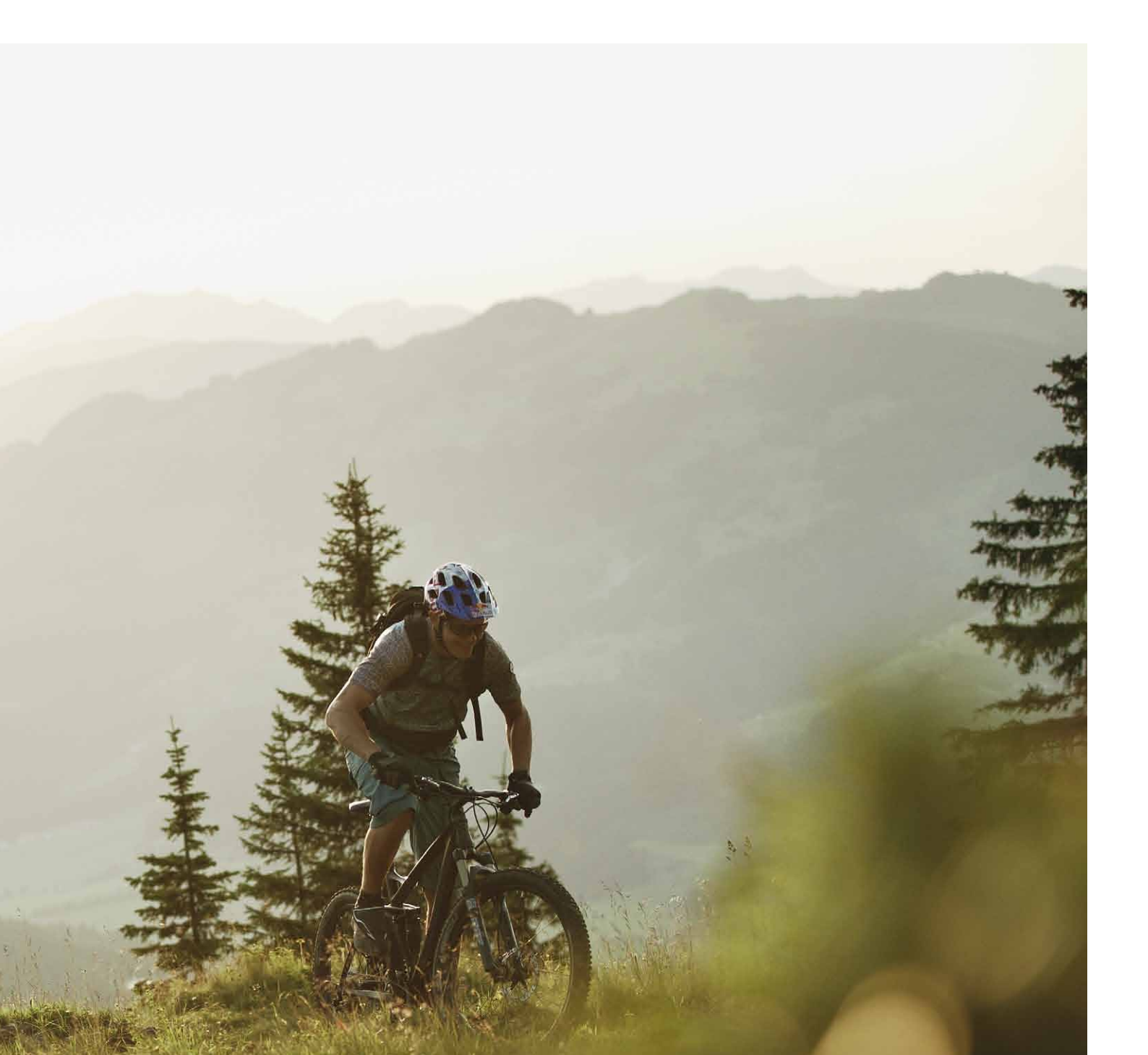

Das frühe Aufstehen hat sich gelohnt. Der größte Teil des Aufstiegs liegt bereits hinter dir, und während du den Gipfel erreichst, erscheinen über den Bergen die ersten Sonnenstrahlen. Nach einer kurzen Rast versenkst du deine Sattelstütze und genießt die Abfahrt über die flowigen Trails. Dabei ist egal, ob Steinpassage oder Waldboden, dein AMR ist für alles zu haben.

Getting up early was worth it. The biggest part of the climb is already behind you. As you reach the summit, the first beams of sunlight appear over the mountains. After a short break, you adjust your seatpost down and enjoy the downhill over the flowing trails. It won't matter if you cross rock passages or forest ground, your AMR is up for everything.

AMR LECTOR 2995 E:i

BLACK / GREY / RED



Mit diesem Bike revolutionieren wir die All Mountain-Klasse! Unseren superleichten AMR Carbonrahmen haben wir perfekt auf die 29-Zoll-Laufräder abgestimmt. Beste Traktion und höchste Performance in technischen Abfahrten sind garantiert. Für das optimale Setup des Fahrwerks sorgt unsere E:i Fahrwerkstechnologie. Dazu eine Shimano XTR-Schaltgruppe und top Anbauteile. Die neue Benchmark der Trail-Klasse heißt AMR Lector 2995 E:i.

This bike revolutionizes the All Mountain class! Our super lightweight AMR carbon frame is perfectly tuned to the 29 inch wheelset. Best possible traction and optimum performance on technical downhills is guaranteed. Our E:i chassis suspension technology ensures optimum chassis setup. In addition, it sports the Shimano XTR groupset and premium components. The AMR Lector 2995 E:i is the new benchmark in the trail class.



SCL SPECIFIC
CHAINSTAY LENGTH

ANTI-SQUAT
TECHNOLOGY



	AMR 29 HM Carbon/Alloy MIMS SCL		Shimano XTR 42-32-24
	Ritchey WCS 31.8 mm		Magura MT8 Disc 180 mm
	Rock Shox SID 29 RLT PopLoc 110 mm Tapered 15 mm		Schwalbe Rocket Ron 2.25
	Ritchey Pro Tapered		Schwalbe Rocket Ron 2.25
	Ritchey WCS Carbon UD Rizer 9 D 710 mm 31.8 mm		Easton EA 70 XCT Wheelset
	Ritchey WCS Carbon Monolink 31.6 mm		Easton EA 70 XCT Wheelset
	Selle Italia SLR Monolink XP		Easton EA 70 XCT Wheelset
	Shimano XTR 10-Speed		Shimano XTR 10-Speed 11-36
	Shimano XTR		SRAM Monarch E:i Shock 100 mm
	Shimano XTR SL		110 mm
	Magura MT8		100 mm
	Shimano Pressfit BB		40/44/48/52/56 cm
			11.20 kg

AMR LECTOR 2990

BLACK / GREY / RED



- | | | | |
|---|---|--|---|
| <ul style="list-style-type: none"> AMR 29 HM Carbon/Alloy MIMS SCL Ritchey WCS 31.8 mm FOX Forx 32F 29 Air FIT CTD Remote 110 mm Kashima Tapered 15 QR FSA Tapered Ritchey WCS Carbon UD Rizer 9 D 710 mm 31.8 mm Ritchey WCS Carbon Monolink 31.6 mm | <ul style="list-style-type: none"> Selle Italia SLR Monolink XP Shimano XTR 10-Speed Shimano XTR Shimano XTR SL Magura MT8 Shimano Pressfit BB Shimano XTR 42-32-24 | <ul style="list-style-type: none"> Magura MT8 Disc 180 mm Schwalbe Rocket Ron 2.25 Schwalbe Rocket Ron 2.25 Easton EA 70 XCT Wheelset Easton EA 70 XCT Wheelset Easton EA 70 XCT Wheelset Shimano XTR 10-Speed 11-36 | <ul style="list-style-type: none"> FOX Float CTD XV Kashima Boost Valve Adjust 100 mm 110 mm 100 mm 40/44/48/52/56 cm kg 10.90 kg |
|---|---|--|---|

AMR LECTOR 2978

BLACK / GREY / LIME GREEN



- | | | | |
|---|---|---|--|
| <ul style="list-style-type: none"> AMR 29 HM Carbon/Alloy MIMS SCL GHOST light AS-029 31.8 mm FOX Forx 32F 29 Air CTD Remote 110 mm Tapered 15 QR FSA Tapered GHOST Flat light 700mm 31.8 mm CG Carbon SL 31.6 mm | <ul style="list-style-type: none"> Selle Royal Seta Shimano XT 10-Speed Shimano XT Shimano XT SL Shimano XT Shimano Pressfit BB Shimano XT 42-32-24 | <ul style="list-style-type: none"> Shimano XT Disc 180 mm Schwalbe Rocket Ron 2.25 Schwalbe Rocket Ron 2.25 Alex FD19 DT Swiss 1.8 Shimano XT Shimano XT 10-Speed 11-36 | <ul style="list-style-type: none"> FOX Float CTD 100 mm Boost Valve 110mm 100 mm 40/44/48/52/56 cm kg 11.60 kg |
|---|---|---|--|

AMR 2976



GREY / BLACK / BLUE



-  AMR 29 Actinum DB SCL
-  GHOST light A5-029 31.8 mm
-  FOX Forx 32F 29 Air CTD Remote 110 mm Tapered 15 QR
-  Ritchey Tapered
-  GHOST Flat light 700mm 31.8 mm
-  GHOST SL SP 717 31.6 mm

-  Selle Royal Seta
-  Shimano XT 10-Speed
-  Shimano XT
-  Shimano XT SL
-  Shimano XT
-  Shimano Pressfit BB
-  Shimano XT 42-32-24

-  Shimano XT Disc 180 mm
-  Schwalbe Rocket Ron 2.25
-  Schwalbe Rocket Ron 2.25
-  Alex FD19
-  DT Swiss 1.8
-  Shimano XT
-  Shimano XT 10-Speed 11-36







-  FOX Float CTD 100 mm Boost Valve
-  110 mm
-  100 mm
-  40/44/48/52/56 cm
-  kg 12.60 kg

AMR 2955

SILVER / WHITE / GREY



-  AMR 29 Actinum DB SCL
-  GHOST light A5-029 31.8 mm
-  Rock Shox Reba 29 RL Solo Air PopLoc 110 mm Tapered 15 QR
-  Ritchey Tapered
-  GHOST Flat light 700mm 31.8 mm
-  GHOST SL SP 717 31.6 mm

-  Selle Royal Seta
-  Shimano XT 10-Speed
-  Shimano SLX
-  Shimano Deore SL
-  Shimano 596
-  Shimano Pressfit BB
-  Shimano FCM 552 42-32-24

-  Shimano 596 Disc 180 mm
-  Schwalbe Rocket Ron 2.25
-  Schwalbe Rocket Ron 2.25
-  Alex FD19
-  DT Swiss 1.8
-  Shimano SLX
-  SRAM PG-1030 11-36

-  FOX Float CTD 100 mm
-  110 mm
-  100 mm
-  40/44/48/52/56 cm
-  kg 13.00 kg

AMR LECTOR 9600 E:i

BLACK / GREY / RED



Unser AMR Lector Topmodell haben wir mit dem besten Fahrwerk ausgestattet, das es derzeit gibt. Perfekte Abstimmung in jeder Fahrsituation dank E:i Fahrwerkstechnologie. Dazu Komponenten, die keinerlei Wünsche offen lassen. Geschmeidige Gangwechsel mit der Shimano XTR und leichte Easton EA70 Laufräder machen jeden Tag auf dem Trail zu einem unvergesslichen Tag!

Our AMR Lector top model features the best chassis that is currently on the market. The E:i chassis suspension technology provides perfect tuning in any riding situation. In addition, the components leave nothing to be desired. Smooth gear shifting with the Shimano XTR rear derailleur system and a lightweight Easton EA 70 wheelset make any day on the trail an unforgettable experience.



SCL SPECIFIC
CHAINSTAY LENGTH

ANTI-SQUAT
TECHNOLOGY



VORJAHRESMODELL GETESTET
RATING FOR LAST YEARS MODEL



	AMR Plus HM Carbon/Carbon MIMS SCL		Shimano XTR 42-32-24
	Ritchey WCS 31.8 mm		Magura MT8 Disc 180 mm
	Rock Shox SID World Cup XX 120 mm Tapered 15 mm		Schwalbe Nobby Nic 2.25
	Ritchey WCS Tapered		Schwalbe Nobby Nic 2.25
	Ritchey WCS Carbon UD Rizer 9 D 710 mm 31.8 mm		Easton EA 70 XCT Wheelset
	Ritchey WCS Carbon Monolink 31.6 mm		Easton EA 70 XCT Wheelset
	Selle Italia SLR Monolink XP		Easton EA 70 XCT Wheelset
	Shimano XTR 10-Speed		Shimano XTR 11-34
	Shimano XTR		SRAM Monarch E:i Shock 120 mm
	Shimano XTR SL		120 mm
	Magura MT8		120 mm
	Shimano Pressfit BB		40/44/48/52/56 cm
			10.30 kg

AMR LECTOR 9500

BLACK / GREY / RED



VORJAHRESMODELL GETESTET
RATING FOR LAST YEARS MODELL

ÜBERRAGEND

- | | | | |
|---|------------------------------|---------------------------|--|
| AMR UHM Carbon/Carbon MIMS SCL | Selle Italia SLR Monolink XP | Magura MT8 Disc 180 mm | FOX Float CTD Kashima 120 mm Boost Valve |
| Ritchey WCS 31.8 mm | Shimano XTR 10-Speed | Schwalbe Nobby Nic 2.25 | 120 mm |
| FOX Forx 32F Air FIT Kashima RLC 120 mm Tapered 15 QR | Shimano XTR | Schwalbe Nobby Nic 2.25 | 120 mm |
| Ritchey WCS Tapered | Shimano XTR SL | Easton EA 70 XCT Wheelset | 40/44/48/52/56 cm |
| Ritchey WCS Carbon UD Rizer 9 D 710 mm 31.8 mm | Magura MT8 | Easton EA 70 XCT Wheelset | kg 10.00 kg |
| Ritchey WCS Carbon Monolink 31.6 mm | Shimano Pressfit BB | Easton EA 70 XCT Wheelset | |
| | Shimano XTR 42-32-24 | Shimano XTR 11-34 | |

AMR LECTOR 8500 E:1

BLACK / GREY / GREY BLUE



- | | | | |
|--|---------------------|-------------------------|-------------------------------|
| AMR HM Carbon/Alloy MIMS SCL | Selle Royal Seta | Shimano XT Disc 180 mm | SRAM Monarch E:i Shock 120 mm |
| GHOST light ASA-106 31.8 mm | Shimano XT 10-Speed | Schwalbe Nobby Nic 2.25 | 120 mm |
| Rock Shox Reba RL Solo Air PopLoc 120 mm Tapered 15 mm | Shimano XT | Schwalbe Nobby Nic 2.25 | 120 mm |
| Ritchey Tapered | Shimano XT SL | Alex FD19 | 40/44/48/52/56 cm |
| GHOST Low Rizer light 680 mm 31.8 mm | Shimano XT | DT Swiss 1.8 | kg 12.00 kg |
| CG Carbon SL 31.6 mm | Shimano Pressfit BB | Shimano XT | |
| | Shimano XT 42-32-24 | Shimano XT 11-34 | |

AMR LECTOR 7700

BLACK / GREY / GREY BLUE



- | | | | |
|--|------------------------|----------------------------------|-------------------|
| AMR HM Carbon/Alloy MIMS SCL | Shimano XT 10-Speed | Schwalbe Nobby Nic 2.25 | 120 mm |
| GHOST light ASA-106 31.8 mm | Shimano XT | Schwalbe Nobby Nic 2.25 | 120 mm |
| FOX Forx 32F D/C CTD 120 mm Tapered 15QR | Shimano XT SL | Alex FD19 | 40/44/48/52/56 cm |
| Ritchey Tapered | Shimano XT | DT Swiss 1.8 | kg 11.70 kg |
| GHOST Low Rizer light 680 mm 31.8 mm | Shimano Pressfit BB | Shimano XT | |
| CG Carbon SL 31.6 mm | Shimano XT 42-32-24 | Shimano XT 11-34 | |
| Selle Royal Seta | Shimano XT Disc 180 mm | FOX Float CTD 120 mm Boost Valve | |

AMR 7500

GREY / GREY / LIME GREEN



























- | | | | |
|--|------------------------|----------------------------------|-------------------|
| AMR Actinum DB SCL | Shimano XT 10-Speed | Schwalbe Nobby Nic 2.25 | 120 mm |
| GHOST light ASA-106 31.8 mm | Shimano XT | Schwalbe Nobby Nic 2.25 | 120 mm |
| FOX Forx 32F D/C CTD 120 mm Tapered 15QR | Shimano XT SL | Alex FD19 | 40/44/48/52/56 cm |
| Ritchey Tapered | Shimano XT | DT Swiss 1.8 | kg 12.40 kg |
| GHOST Low Rizer light 680 mm 31.8 mm | Shimano Pressfit BB | Shimano XT | |
| GHOST SL SP 717 31.6 mm | Shimano XT 42-32-24 | Shimano XT 11-34 | |
| Selle Royal Seta | Shimano XT Disc 180 mm | FOX Float CTD 120 mm Boost Valve | |

AMR 7500

BLACK / GREY / GREY RED



























 AMR Actinum DB SCL	 Shimano XT 10-Speed	 Schwalbe Nobby Nic 2.25	 120 mm
 GHOST light ASA-106 31.8 mm	 Shimano XT	 Schwalbe Nobby Nic 2.25	 120 mm
 FOX Forx 32F O/C CTD 120 mm Tapered 15QR	 Shimano XT SL	 Alex FD19	 40/44/48/52/56 cm
 Ritchey Tapered	 Shimano XT	 DT Swiss 1.8	 kg 12.40 kg
 GHOST Low Rizer light 680 mm 31.8 mm	 Shimano Pressfit BB	 Shimano XT	
 GHOST SL SP 717 31.6 mm	 Shimano XT 42-32-24	 Shimano XT 11-34	
 Selle Royal Seta	 Shimano XT Disc 180 mm	 FOX Float CTD 120 mm Boost Valve	

AMR 5900

BLACK / WHITE / RED



























 AMR Actinum DB SCL	 Shimano XT 10-Speed	 Schwalbe Nobby Nic 2.25	 120 mm
 GHOST light ASA-106 31.8 mm	 Shimano SLX	 Schwalbe Nobby Nic 2.25	 120 mm
 FOX Forx 32F O/C CTD 120mm Tapered	 Shimano SLX SL	 Alex FD19	 40/44/48/52/56 cm
 Ritchey Tapered	 Shimano 596	 DT Swiss 1.8	 kg 12.70 kg
 GHOST Low Rizer light 680 mm 31.8 mm	 Shimano Pressfit BB	 Shimano Deore	
 GHOST SL SP 717 31.6 mm	 Shimano XT 42-32-24	 SRAM PG-1030 11-36	
 Selle Royal Seta	 Shimano 596 Disc 180 mm	 FOX Float CTD SV 120mm	

AMR 5700

BLACK / BLUE / LIME GREEN



- | | | | |
|--|--|--|--|
|  AMR Actinum DB SCL |  Shimano XT 10-Speed |  Schwalbe Nobby Nic 2.25 |  120 mm |
|  GHOST light ASA-106 31.8 mm |  Shimano SLX |  Schwalbe Nobby Nic 2.25 |  120 mm |
|  FOX Forx 32F O/C CTD 120mm Tapered |  Shimano Deore SL |  Alex FD19 |  40/44/48/52/56 cm |
|  Ritchey Tapered |  Shimano 505 |  DT Swiss 1.8 |  kg 12.90 kg |
|  GHOST Low Rizer light 680 mm 31.8 mm |  Shimano Pressfit BB |  Shimano Deore | |
|  GHOST SL SP 717 31.6 mm |  Shimano FCM 552 42-32-24 |  SRAM PG-1030 11-36 | |
|  Selle Royal Seta |  Shimano 505 Disc 180 mm |  FOX Float CTD SV 120mm | |



ASX 5500

BLACK / GREY / RED



Das Topmodell der ASX-Klasse! Leichter Alurahmen, Fox Gabel und X-Fusion Dämpfer, natürlich luftgefedert. Dazu Avid Scheibenbremsen und eine Shimano XT 30-Gang-Schaltung. Erlebe beste Performance kombiniert mit Zuverlässigkeit und leichtem Gewicht. Ein echtes Topmodell eben.

The top model of the ASX class! The bike features a light-weight aluminum frame, Fox fork and X-Fusion damper, naturally with air suspension. Avid disc brakes and a Shimano XT 30-speed drivetrain are also included. Experience optimum performance combined with reliability and low weight. A truly top model.

SCL SPECIFIC
CHAINSTAY LENGTH

THT | TAPERED
HEAD TUBE



























	ASX 7005 DB		Avid Elixir 3 180 mm
	GHOST light AS-007N 31.8 mm		Schwalbe Rocket Ron 2.25
	FOX Forx 32F O/C CTD 120mm Tapered		Schwalbe Rocket Ron 2.25
	Ritchey Tapered		Alex XD Sport
	GHOST Low Rizer light 680 mm 31.8 mm		DT Swiss 1.8
	GHOST light SP DC 1 31.6 mm		SRAM 506
	GHOST VL 1535		SRAM PG-1030 11-36
	Shimano XT 10-Speed		X-Fusion E1 RL Air 120 mm
	Shimano Deore		120 mm
	Shimano Deore SL		120 mm
	Avid Elixir 3		40/44/48/52/56 cm
	Shimano BB51 BSA		13.20 kg
	Shimano FCM 552 42-32-24		

ASX 5100

GREY / BLACK / LIME



























 ASX 7005 DB	 Shimano XT 10-Speed	 Schwalbe Smart Sam 2.25	 120 mm
 GHOST light AS-007N 31.8 mm	 Shimano Deore	 Schwalbe Smart Sam 2.25	 120 mm
 Rock Shox XC 32 Solo Air PopLoc Tapered 120 mm	 Shimano Deore SL	 Ryde Taurus	 40/44/48/52/56 cm
 Ritchey Tapered	 Shimano 505	 DT Swiss 1.8	 kg 13.60 kg
 GHOST Low Rizer light 680 mm 31.8 mm	 Shimano BB51 BSA	 Shimano Deore	
 GHOST light SP DC 1 31.6 mm	 Shimano FCM 552 42-32-24	 SRAM PG-1030 11-36	
 GHOST VL 1535	 Shimano 505 Disc 180 mm	 X-Fusion E1 RL Air 120 mm	

ASX 4900

SILVER / BLUE / LIME



 ASX 7005 DB	 Shimano Deore 9-Speed	 Schwalbe Smart Sam 2.25	 120 mm
 GHOST light AS-007N 31.8 mm	 Shimano Alivio	 Schwalbe Smart Sam 2.25	 120 mm
 Suntour Raidon AIR RL 120 mm	 Shimano Acera SL	 Ryde Taurus	 40/44/48/52/56 cm
 Ritchey	 Tektro HDC 300	 DT Swiss 1.8	 kg 14.30 kg
 GHOST Low Rizer light 680 mm 31.8 mm	 Shimano BBES-25	 SRAM 306	
 GHOST light SP DC 1 31.6 mm	 Shimano Acera 44-32-22	 Shimano 11-32	
 GHOST VL 1535	 Tektro HDC 300 Disc 160 mm	 X-Fusion E1 RL Air 120 mm	



AMR PLUS





Nach dem Frühstück auf der Hütte bist du bereit für die letzten Höhenmeter. Dank der effizienten Geometrie sind auch diese schnell geschafft. Du legst deine Protpektoren an und fährst voller Vorfreude in den Trail hinein. Durch den niedrigen Schwerpunkt sind auch plötzliche Richtungswechsel und Spitzkehren kein Problem. Bei kurzen Zwischenanstiegen punktest du mit deiner vom Lenker aus verstellbaren Sattelstütze. Viel zu schnell tauchen zwischen den Bäumen schon die Häuser im Tal auf. Schon jetzt planst du in deinen Gedanken deine nächste Hüttentour.

After breakfast in the lodge, you are ready to take on the last vertical climb. Thanks to the efficient geometry, you get there quickly. You put on your protectors and full of anticipation, you enter the trail. Due to the low center of gravity, sudden directional changes and hairpin bends are no problem. On the short ascents in between, you score big time with your seatpost, which adjusts remotely from the handlebar. Much too soon, you can make out the houses in the valley through the trees. Time to plan your next Alpine tour.

AMR PLUS LECTOR 9100 E:i

BLACK / GREY / RED



Unser AMR Plus Lector 9100 E:i ist ein Allmountain Bike der Superlative. Unseren 150mm Carbon Rahmen haben wir mit der besten Fahrwerkstechnologie ausgerüstet, die es derzeit gibt: E:i. Beste Performance zu jedem Zeitpunkt ist garantiert. Dazu Sram X.0 Schaltgruppe, leichte Easton Haven Laufräder und eine Rock Shox Reverb Sattelstütze. Das perfekte Bike für jedes Gelände. Allmountain auf einem neuen Level!

The AMR Plus Lector 9100 E:i is an Allmountain bike of superlatives. Our 150mm carbon frame features the best chassis technology currently available: E:i. Best performance is guaranteed at all times. Sram X.0 groupset, lightweight Easton Haven wheelset and a Rock Shox Reverb seat post round off the package. The perfect bike for any terrain. Allmountain on a totally new level!



SCL SPECIFIC CHAINSTAY LENGTH

VORJAHRESMODELL, GETESTET
RATING FOR LAST YEARS MODEL



	AMR Plus HM Carbon/Alloy MIMS SCL		SRAM X.0 44-33-22
	Ritchey WCS 31.8 mm		SRAM X.0 Disc 180 mm
	Rock Shox Revelation World Cup 150-120 mm Tapered 15 mm		Schwalbe Nobby Nic 2.35
	FSA RC Tapered		Schwalbe Nobby Nic 2.35
	Ritchey WCS Carbon Trail UD Rizer 15/9 740 mm 31.8 mm		Easton Haven Wheelset
	Rock Shox Reverb 31.6 Travel 100 mm		Easton Haven Wheelset
	Selle Italia SLR TT Titanium		Easton Haven Wheelset
	SRAM X.0 Type 2 10-Speed		SRAM PG 1070 11-36
	SRAM X.0		SRAM Monarch E:i Shock 150 mm
	SRAM X.0 Trigger		150/120 mm
	SRAM X.0		150 mm
	SRAM Pressfit BB		40/44/48/52/56 cm
			12.20 kg

AMR PLUS LECTOR 9000

BLACK / GREY / RED



VORJAHRESMODELL GETESTET
RATING FOR LAST YEARS MODELL

BIKE SEHR GUT



- AMR Plus HM Carbon/Alloy MIMS SCL
- Ritchey WCS 31.8 mm
- FOX Forx Talas Air FIT CTD Kashima 2-Position 150/120 mm Tapered
- FSA RC Tapered
- Ritchey WCS Carbon Trail UD Rizer 15/9 740 mm 31.8 mm
- Rock Shox Reverb 31.6 Travel 100 mm

- Selle Italia SLR TT Titanium
- SRAM X.0 Type 2 10-Speed
- SRAM X.0
- SRAM X.0 Trigger
- SRAM X.0
- SRAM Pressfit BB
- SRAM X.0 44-33-22

- SRAM X.0 Disc 180 mm
- Schwalbe Nobby Nic 2.35
- Schwalbe Nobby Nic 2.35
- Easton Haven Wheelset
- Easton Haven Wheelset
- Easton Haven Wheelset
- SRAM PG 1070 11-36

- FOX Float CTD XV Kashima Trail Adjust 150 mm
- 150/120 mm
- 150 mm
- 40/44/48/52/56 cm
- kg 11.90 kg

AMR PLUS LECTOR 7700

BLACK / GREY / LIME GREEN



VORJAHRESMODELL GETESTET
RATING FOR LAST YEARS MODELL

BIKE TIPP
URTEIL/PUNKTE SEHR GUT/128,25

- AMR Plus HM Carbon/Alloy MIMS SCL
- GHOST light 23A 31.8 mm
- FOX Forx Talas Air FIT CTD 2-Position 150/120 mm Tapered 15 QR
- FSA RC Tapered
- GHOST Low Rizer light 740 mm 31.8 mm
- X-Fusion Hilo 31.6 mm Travel 100 mm

- Selle Royal Seta
- Shimano XT Plus 10-Speed
- Shimano XT
- Shimano XT SL
- Shimano XT
- Shimano Pressfit BB
- Shimano XT 42-32-24

- Shimano XT Disc 180 mm
- Schwalbe Nobby Nic 2.35
- Schwalbe Nobby Nic 2.35
- Alex XED 44 Disc
- DT Swiss 1.8
- Shimano XT
- Shimano XT 10-Speed 11-36

- Fox Float CTD BV SV XV 150 mm
- 150/120 mm
- 150 mm
- 40/44/48/52/56 cm
- kg 12.80 kg

AMR PLUS 7500

BLACK / GREY / BLUE

VORJAHRESMODELL GETESTET
RATING FOR LAST YEARS MODEL

bike ÜBERRAGEND

bike
BEST BIKE 2012 (Bike 10/2011)
Ghost
AMR Plus 7500

KAUFTIP
BEST BIKE



- | | | | |
|--|--|---|---|
|  AMR Plus Actinum DB SCL |  Selle Royal Seta |  Shimano XT Disc 180 mm |  Fox Float CTD BV SV XV 150 mm |
|  GHOST light 23A 31.8 mm |  Shimano XT Plus 10-Speed |  Schwalbe Nobby Nic 2.35 |  150/120 mm |
|  FOX Forx Talas Air FIT CTD 2-Position
150/120 mm Tapered 15 QR |  Shimano XT |  Schwalbe Nobby Nic 2.35 |  150 mm |
|  FSA RC Tapered |  Shimano XT SL |  Alex XED 44 Disc |  40/44/48/52/56 cm |
|  GHOST Low Rizer light 740 mm 31.8 mm |  Shimano XT |  DT Swiss 1.8 |  kg 13.50 kg |
|  X-Fusion Hilo 31.6 mm Travel 100 mm |  Shimano Pressfit BB |  Shimano XT | |
| |  Shimano XT 42-32-24 |  Shimano XT 10-Speed 11-36 | |

























AMR PLUS 5900

RAW / GREY / BLUE

VORJAHRESMODELL GETESTET
RATING FOR LAST YEARS MODEL

bike
BEST BIKE 2012 (Bike 12/2011)
Ghost
AMR Plus 5900



- | | | | |
|---|--|---|--|
|  AMR Plus Actinum DB SCL |  Selle Royal Seta |  Shimano 596 Disc 180 mm |  X-Fusion O2 RCX 150 mm |
|  GHOST light 23A 31.8 mm |  Shimano XT Plus 10-Speed |  Schwalbe Nobby Nic 2.35 |  150/120 mm |
|  FOX Forx Talas Air FIT CTD 2-Position
150/120 mm Tapered 15 QR |  Shimano SLX |  Schwalbe Nobby Nic 2.35 |  150 mm |
|  FSA RC Tapered |  Shimano Deore SL |  Alex XED 44 Disc |  40/44/48/52/56 cm |
|  GHOST Low Rizer light 740 mm 31.8 mm |  Shimano 596 |  DT Swiss 1.8 |  kg 13.90 kg |
|  X-Fusion Hilo 31.6 mm Travel 100 mm |  Shimano Pressfit BB |  Shimano SLX | |
| |  Shimano FCM 552 42-32-24 |  SRAM PG-1030 11-36 | |

CAGUA 6591 E:i

GREY / BLACK / ORANGE



Der Name Cagua 650B steht für den neuen Allmountain Standard. Die 650B Lauf-
 räder stehen für mehr Grip, bessere Traktion und höhere Geschwindigkeit. Unseren neuen
 Alurahmen mit 160mm Federweg haben wir perfekt darauf abgestimmt. Das revolutionäre E:i
 Federungskonzept garantiert das optimale Setup in jedem Gelände. Logisch, dass bei
 diesem Bike nur beste Komponenten zum Einsatz kommen. Das Cagua 6591 E:i ist ein
 Allmountainbike in Perfektion. Shred it!

*The name Cagua 650B stands for the new allmountain standard. The 650B wheels mean
 more grip, better Traction, higher speeds, and our new aluminum frames with 160mm of travel
 were perfectly tuned to it. The revolutionary E:i shock concept guarantees the optimal setup
 in any terrain. It just makes sense that this bike features the best components available. The
 cagua 6591 E:i is the ultimate allmountain bike. Shred it!*









	Cagua 650B Actinum DB SCL		SRAM X.0 38-24
	Ritchey WCS 31.8 mm		Shimano Saint Disc 203/180 mm
	FOX Forx 34 Talas 650B FIT CTD Kashima 160/120 mm Tapered 15QR		Schwalbe Nobby Nic 650B 2.35
	FSA RC Tapered		Schwalbe Nobby Nic 650B 2.35
	Ritchey WCS Carbon Trail UD Rizer 15/9 740 mm 31.8 mm		Alex SX 44 Disc
	Rock Shox Reverb 31.6 Travel 100 mm		DT Swiss 1.8
	Selle Royal Seta		Shimano XT
	SRAM X.0 Type 2 10-Speed		SRAM PG 1070 11-36
	SRAM X.0		SRAM Monarch E:i Shock 155 mm
	SRAM X.0 Trigger		160/120 mm
	Shimano Saint		155 mm
	SRAM Pressfit BB		40/44/48/52/56 cm
			13.90 kg







CAGUA 6590





GREY / BLACK / ORANGE



-  Cagua 650B Actinum DB SCL
-  Ritchey WCS 31.8 mm
-  FOX Forx 34 Talas 650B FIT CTD Kashima 160/120 mm Tapered 15QR
-  FSA RC Tapered
-  Ritchey WCS Carbon Trail UD Rizer 15/9 740 mm 31.8 mm
-  Rock Shox Reverb 31.6 Travel 100 mm

-  Selle Royal Seta
-  SRAM X.0 Type 2 10-Speed
-  SRAM X.0
-  SRAM X.0 Trigger
-  Shimano Saint
-  SRAM Pressfit BB
-  SRAM X.0 38-24

-  Shimano Saint Disc 203/180 mm
-  Schwalbe Nobby Nic 650B 2.35
-  Schwalbe Nobby Nic 650B 2.35
-  Alex SX 44 Disc
-  DT Swiss 1.8
-  Shimano XT
-  SRAM PG 1070 11-36

-  Fox Float CTD XV Kashima Trail Adjust 155 mm
-  160/120 mm
-  155 mm
-  40/44/48/52/56 cm
-  kg 13.60 kg

CAGUA 6551 E:I





RAW / BLUE / LIME GREEN



-  Cagua 650B Actinum DB SCL
-  GHOST light 23A 31.8 mm
-  FOX Forx 34 Talas 650B O/C CTD 160/120 mm Tapered 15QR
-  FSA RC Tapered
-  GHOST Low Rizer light 740 mm 31.8 mm
-  Rock Shox Reverb 31.6 Travel 100 mm

-  Selle Royal Seta
-  Shimano XT Plus 10-Speed
-  Shimano XT
-  Shimano XT SL
-  Shimano XT
-  Shimano Pressfit BB
-  Shimano XT 38-24

-  Shimano XT Disc 203/180 mm
-  Schwalbe Nobby Nic 650B 2.35
-  Schwalbe Nobby Nic 650B 2.35
-  Alex SX 44 Disc
-  DT Swiss 1.8
-  Shimano XT
-  SRAM PG 1070 11-36

-  SRAM Monarch E:i Shock 155 mm
-  160/120 mm
-  155 mm
-  40/44/48/52/56 cm
-  kg 14.10 kg

CAGUA 6550

RAW / BLUE / LIME GREEN



▸ Cagua 650B Actinum DB SCL

▸ GHOST light 23A 31.8 mm

▸ FOX Forx 34 Talas 650B O/C CTD
160/120 mm Tapered 15QR

▸ FSA RC Tapered

▸ GHOST Low Rizer light 740 mm 31.8 mm

▸ Rock Shox Reverb 31.6 Travel 100 mm

▸ Selle Royal Seta

▸ Shimano XT Plus 10-Speed

▸ Shimano XT

▸ Shimano XT SL

▸ Shimano XT

▸ Shimano Pressfit BB

▸ Shimano XT 38-24

▸ Shimano XT Disc 203/180 mm

▸ Schwalbe Nobby Nic 650B 2.35

▸ Schwalbe Nobby Nic 650B 2.35

▸ Alex SX 44 Disc

▸ DT Swiss 1.8

▸ Shimano XT

▸ SRAM PG 1070 11-36

▸ Fox Float CTD BV SV XV 155 mm

▸ 160/120 mm

▸ 155 mm

▸ 40/44/48/52/56 cm

kg 13.80 kg

CAGUA 6541 E:I

BLACK / WHITE / GREY



▸ Cagua 650B Actinum DB SCL

▸ GHOST light 23A 31.8 mm

▸ FOX Forx 34 Talas 650B O/C CTD
160/120 mm Tapered 15QR

▸ FSA RC Tapered

▸ GHOST Low Rizer light 740 mm 31.8 mm

▸ X-Fusion Hilo 31.6 mm Travel 100 mm

▸ Selle Royal Seta

▸ Shimano XT Plus 10-Speed

▸ Shimano SLX

▸ Shimano SLX SL

▸ Shimano SLX

▸ Shimano Pressfit BB

▸ Shimano SLX 38-24

▸ Shimano SLX Disc 203/180 mm

▸ Schwalbe Nobby Nic 650B 2.35

▸ Schwalbe Nobby Nic 650B 2.35

▸ Ryde Taurus

▸ DT Swiss 1.8

▸ Shimano SLX

▸ Shimano CS-HG62 11-36

▸ SRAM Monarch E:i Shock 155 mm

▸ 160/120 mm

▸ 155 mm

























▸ 40/44/48/52/56 cm

kg 14.50 kg

CAGUA 6540

BLACK / WHITE / GREY



- | | | | |
|--|--|---|--|
|  Cagua 650B Actinum DB SCL |  Selle Royal Seta |  Shimano SLX Disc 203/180 mm |  X-Fusion O2 RCX 155 mm |
|  GHOST light 23A 31.8 mm |  Shimano XT Plus 10-Speed |  Schwalbe Nobby Nic 650B 2.35 |  160/120 mm |
|  FOX Forx 34 Talas 650B O/C CTD
160/120 mm Tapered 15QR |  Shimano SLX |  Schwalbe Nobby Nic 650B 2.35 |  155 mm |
|  FSA RC Tapered |  Shimano SLX SL |  Ryde Taurus |  40/44/48/52/56 cm |
|  GHOST Low Rizer light 740 mm 31.8 mm |  Shimano SLX |  DT Swiss 1.8 |  kg 14.20 kg |
|  X-Fusion Hilo 31.6 mm Travel 100 mm |  Shimano Pressfit BB |  Shimano SLX | |
| |  Shimano SLX 38-24 |  Shimano CS-HG62 11-36 | |





CAGUA





Der Rucksack ist gepackt, die Route geplant, die Karten gekauft.

Heute lässt du dir von deinem Kumpel neue Trails zeigen, die euren Bikes alles abverlangen. Selbstbewusst fährst du in diese Trails hinein, denn du weißt, auf dein Cagua ist Verlass.

Mit dem 170mm-Fahrwerk überfliegst du alle Hindernisse, die der Berg dir entgegensetzt. Auch kurze Anstiege fallen dir durch die durchdachte Geometrie leicht. Es ist ein ungeschriebenes Gesetz, mit diesem Bike der Schnellere zu sein.

Your backpack is packed, the route is planned, maps are bought.

Today, your buddy shows you new trails which challenge your bikes to their limits. You confidently enter these trails, because you know you can trust your Cagua.

With a 170mm suspension chassis, you fly over all obstacles the mountain has in store for you. Short ascents are easy thanks to the thought-out geometry. It is an unwritten law that you are faster on this bike.

CAGUA 9000

BLACK / BLUE / LIME GREEN



Unser Cagua 9000 hat alles, was ein Enduro der Spitzenklasse ausmacht. Der leichte und stabile Aluminiumrahmen mit sinnvollen Detaillösungen, ein Topfahrwerk und Sram X.0 Antriebskomponenten garantieren beste Performance bergauf wie bergab. Die schaltbare Kettenführung und die Rock Shox Reverb Sattelstütze stellen sicher, dass jeder Ride zum absoluten Highlight wird!

Our Cagua 9000 features everything that sets a premium class Enduro apart: A lightweight and robust aluminum frame with sensible detailed solutions, a top-notch chassis and Sram X.0 drive components guarantee best possible performance on the uphill and the downhill. The adjustable chain guide and Rock Shox Reverb seat post ensure that every ride becomes an absolute highlight!

ISCG

E-TYPE DIRECT

X12

VORJAHRESMODELL GETESTET
RATING FOR LAST YEARS MODELL

bike 05/12
URTEIL/PUNKTE SEHR GUT/11/25

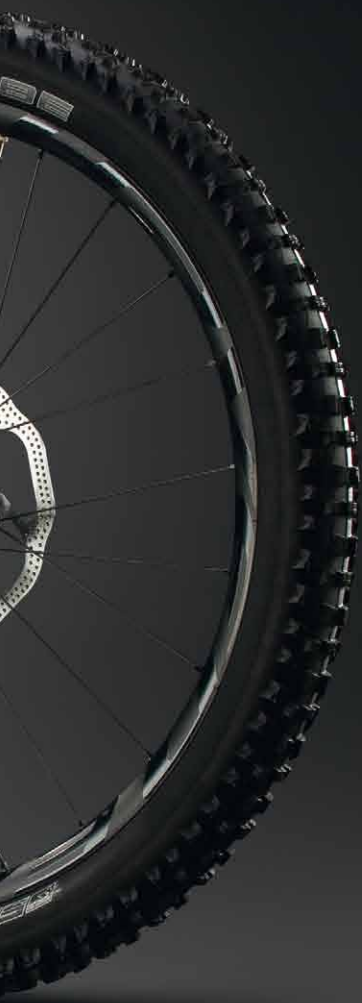





	Cagua 7005 SCL		SRAM X.0 36-22
	Ritchey WCS 31.8 mm		SRAM X.0 Disc 200/180 mm
	FOX Forx 36 Talas RC2 Air FIT Kashima 180/140 mm Tapered 20QR		Schwalbe Fat Albert Front 2.4
	FSA RC Tapered		Schwalbe Fat Albert Rear 2.4
	Ritchey WCS Carbon Trail UD Rizer 15/9 740 mm 31.8 mm		Easton Haven Wheelset
	Rock Shox Reverb 31.6 Travel 100 mm		Easton Haven Wheelset
	Selle Italia SLR XC		Easton Haven Wheelset
	SRAM X.0 10-Speed		SRAM PG 1070 11-36
	SRAM X.0		Cane Creek CCDB Air
	SRAM X.0 Trigger		180/140 mm
	SRAM X.0		170 mm
	SRAM Pressfit BB		40/44/48/52/56 cm
			kg 13.90 kg

CAGUA 7000

RAW / PETROL / ORANGE



- | | | | |
|--|---|---|--|
|  Cagua 7005 SCL |  Shimano XT Plus 10-Speed |  Schwalbe Fat Albert Front 2.4 |  180/140 mm |
|  GHOST light 23A 31.8 mm |  Shimano XT |  Schwalbe Fat Albert Rear 2.4 |  170 mm |
|  FOX Forx 36 TALAS O/B 180/140 mm Tapered 20QR |  Shimano XT SL |  Alex Supra 30 |  40/44/48/52/56 cm |
|  FSA RC Tapered |  Shimano ZEE |  DT Swiss 1.8 |  kg 14.60 kg |
|  GHOST Low Rizer light 740 mm 31.8 mm |  Shimano Pressfit BB |  Shimano ZEE | |
|  X-Fusion Hilo 31.6 mm Travel 100 mm |  Shimano XT 38-26 |  Shimano XT 10-Speed 11-36 | |
|  GHOST VL 1411 |  Shimano ZEE Disc 203/180 mm |  X-Fusion Vector HLR | |





NORTHSHORE





Mit diesem 180mm Fully wird das Spiel aus natürlichen Untergründen, Northshores und der Schwerkraft zu einem absoluten Free-Ride.

With this 180mm fully, the game of natural terrain, Northshores and gravity becomes an absolute free-ride.

NORTHSHORE

RAW / BLACK / GREY



Bei unserem GHOST Northshore ist der Name Programm. Der stabile Alurahmen hält auch größten Belastungen locker stand. Dazu ein Fox Fahrwerk für beste Performance und standfeste Anbauteile. Fertig ist das perfekte Park Bike!

The name says it all: Our GHOST Northshore. The robust aluminum frame can sustain and easily handle the greatest stress loads. A Fox suspension chassis provides best possible performance and steadfast components deliver the rest. Voilà: the absolutely perfect park bike!

ISCG

X12

SMOOTH RATIO
SUSPENSION 2:1



	Northshore 7005 LFT		Avid Elixir 1 Disc 200/180 mm
	Truvativ Hussefelt 31.8 mm		Schwalbe Muddy Mary Performance 2.35
	FOX Forx 36 Van R O/B 180 mm Tapered 20 QR		Schwalbe Muddy Mary Performance 2.35
	FSA RC Tapered		Alex Supra 4X
	Truvativ Boobar 780 mm 31.8 mm		DT Swiss 1.8
	GHOST SL SP 617 31.6 mm		SRAM X.9 X 12 mm
	GHOST VL 1490		Shimano CS-HG81 11-34
	Shimano ZEE 10-Speed		FOX VAN RC 180 mm
	E-Thirteen Chainguard		180 mm
	Shimano Deore SL		180 mm
	Avid Elixir 1		S/M/L
	Truvativ Howitzer XR		kg 17.50 kg
	Truvativ Hussefelt 38		

DOWNHILL





Es ist die Bestzeit, die es zu schlagen gilt. Deine Startzeit von 5 Sekunden ist angebrochen, jetzt zählt nur dieser eine Run. In diesem Moment gibt es nur dich und dein Rad, welches durch sein optimiertes Fahrwerk auf Bestzeiten spezialisiert ist. Dein Platz ist nicht hinter dem Ziel, sondern im Hot Seat.

You have to beat your PR. Your five second countdown has begun, now, all that counts is just this one run. This moment is all about you and your bicycle, which specializes in PRs thanks to its optimized chassis. Your place is not behind the finish, but in the hot seat.

DOWNHILL 9000

RAW / GREY / GREY



Achtung, Suchtgefahr! Mit diesem Bike ist Topspeed garantiert! Unseren Alurahmen mit supersteifer Carbonwippe und allen technischen Raffinessen haben wir mit einem Topfahrwerk ausgestattet. Dazu leichte und stabile Komponenten der absoluten Spitzenklasse. Dieses Bike wurde für Bestzeiten gebaut!

Caution! Addictive substance! This bike guarantees top speed! Our aluminum frame featuring a super stiff carbon rocker and every technical refinement you can think of comes with an ultimate chassis and lightweight, yet sturdy premium class components. This bike is built for PRs!

BOGEY ROLL

X12

FULL CARBON
ROCKER



	DH 7005 LFT BG		Magura MT8 Disc 200/180mm
	Truvativ Holzfeller 31.8 mm		Schwalbe Muddy Mary Performance 2.35
	FOX Forx 40 RC2 FIT Kashima 200 mm Dual Crown 20 QR		Schwalbe Muddy Mary Performance 2.35
	FSA HEADSET		Alex Supra 30
	Syntace Vector DH 780 mm 31.8 mm		Sapim D-Light
	GHOST SL SP 617 31.6 mm		Tune King/Kong X12 mm
	GHOST VL 1411		Shimano Ultegra 11-25
	SRAM X.0 10-Speed		Cane Creek Double Barrel
	MRP Chainguard		200 mm
	SRAM X.0 Trigger		200 mm
	Magura MT8		S/M/L
	SRAM BB BSA		kg
	SRAM X.0 38 Z		16.30 kg

DOWNHILL 7000

BLACK / LIME GREEN / GREY



- | | | | |
|---|--|--|---|
|  DH 7005 LFT BG |  SRAM X.9 10-Speed |  Schwalbe Muddy Mary Performance 2.35 |  200 mm |
|  Truvativ Holzfeller 31.8 mm |  MRP Chainguard |  Schwalbe Muddy Mary Performance 2.35 |  200 mm |
|  Rock Shox Boxxer RC 200 mm 20 mm |  SRAM X.9 Trigger |  Alex Supra 30 |  5/M/L |
|  FSA HEADSET |  Avid Elixir 3 |  DT Swiss 1.8 |  kg 17.70 kg |
|  Truvativ Boobar 780 mm 31.8 mm |  Truvativ Howitzer XR |  SRAM X.9 X 12 mm | |
|  GHOST SL SP 617 31.6 mm |  Truvativ Hussefelt 38 |  Shimano 105 11-25 | |
|  GHOST VL 1411 |  Avid Elixir 3 200/180 mm |  FOX DHX RC2 200 mm | |

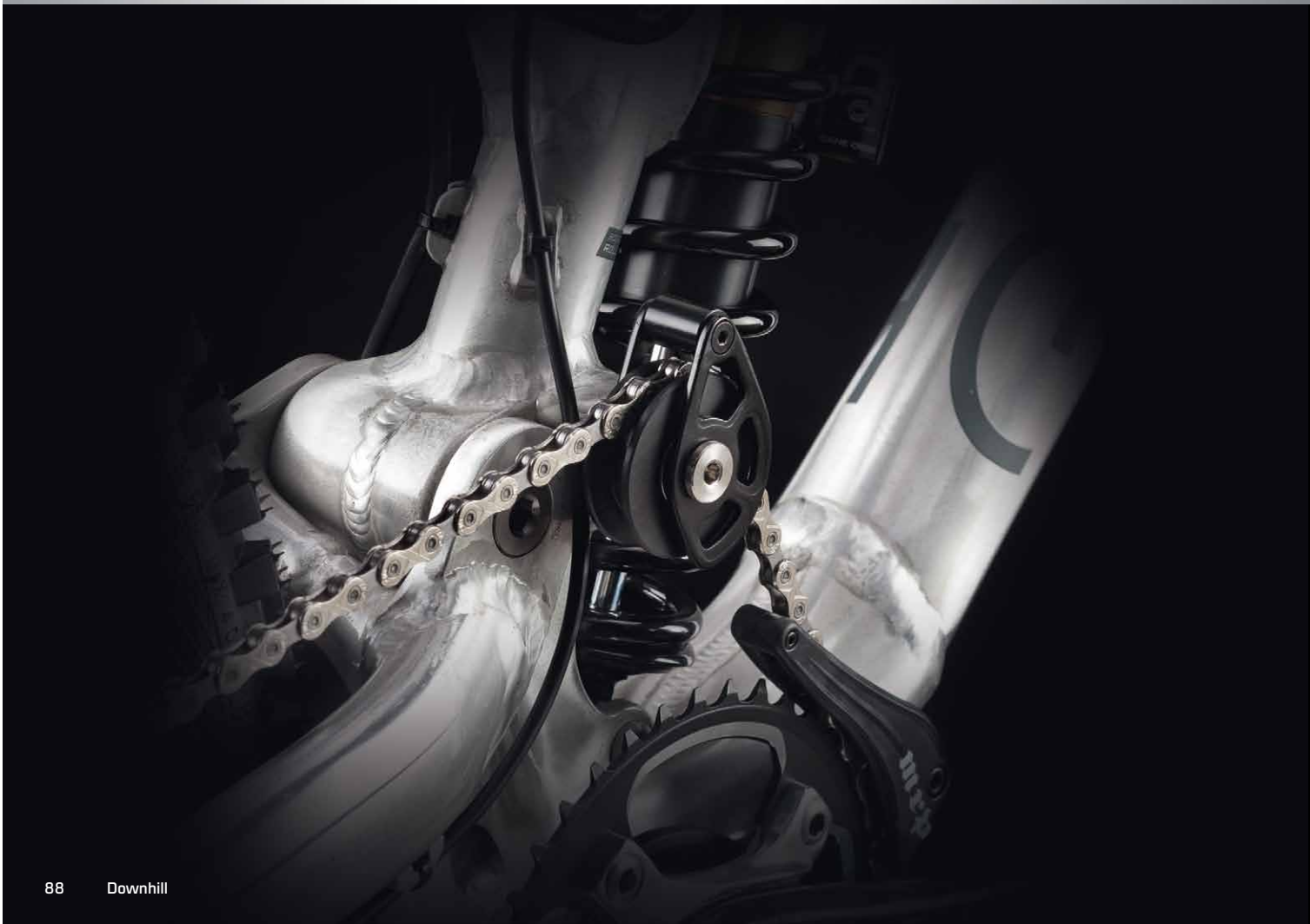



HARDTAIL



HTX 29

Cross Country Race

Marathon Race

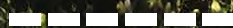
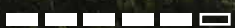

HTX 26

Cross Country Race

Marathon Race

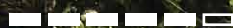
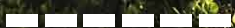

SE 29

Cross Country Tour

Marathon Tour

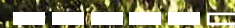
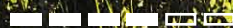

SE 26

Cross Country Tour

Marathon Tour

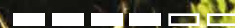
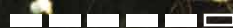



DIRT

Street

Dirt

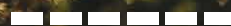

4CROSS

4 Cross

Pumptrack



HTX



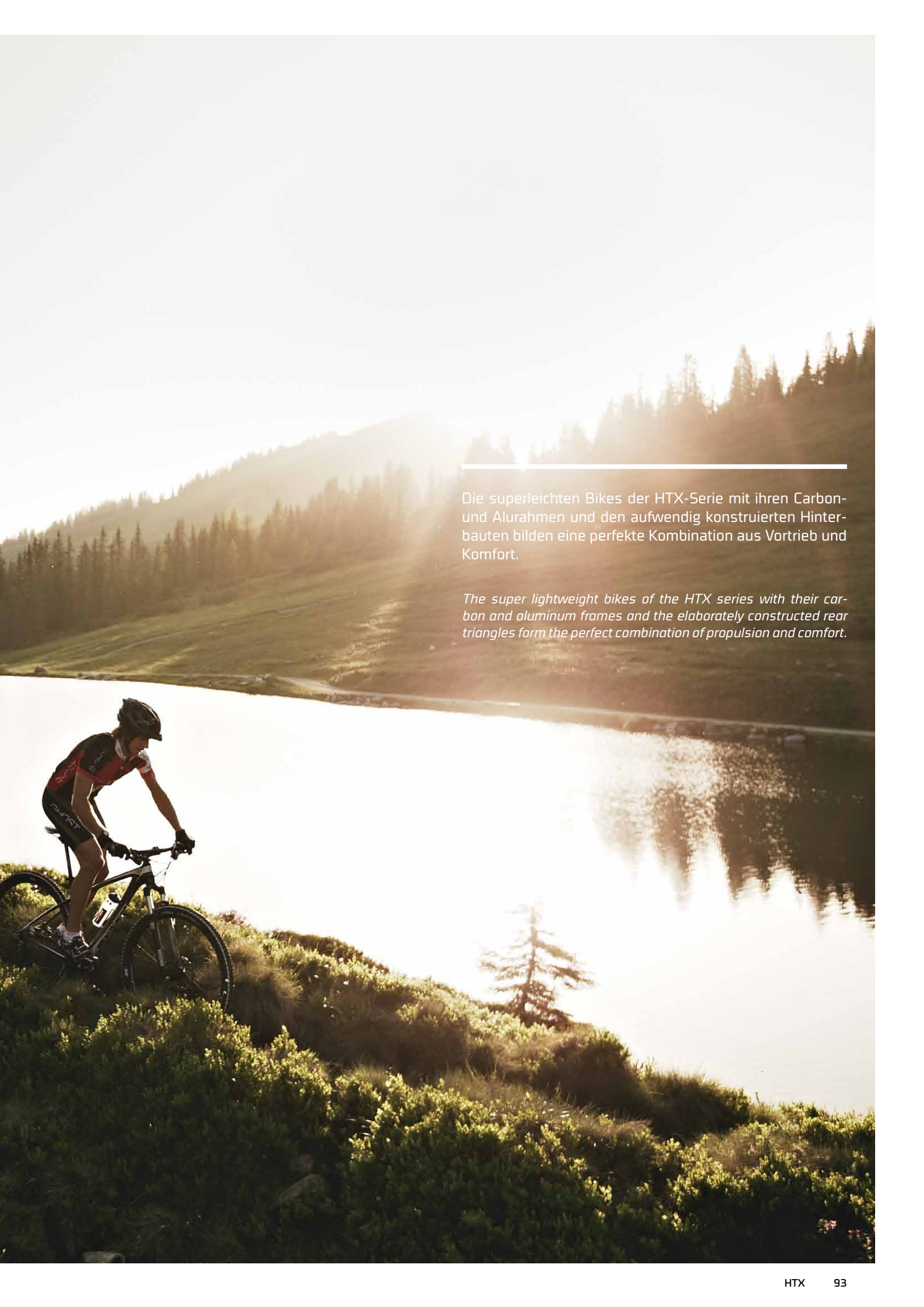

Die superleichten Bikes der HTX-Serie mit ihren Carbon- und Alurahmen und den aufwendig konstruierten Hinterbauten bilden eine perfekte Kombination aus Vortrieb und Komfort.

The super lightweight bikes of the HTX series with their carbon and aluminum frames and the elaborately constructed rear triangles form the perfect combination of propulsion and comfort.

HTX LECTOR 2990

BLACK / GREY / RED



Ein Langstreckenrenner der Superlative! Unseren superleichten Carbonrahmen haben wir mit den besten Komponenten bestückt. Fox Gabel mit Kashima-Beschichtung, Shimano XTR-Schaltgruppe und Ritchey WCS Carbon-Anbauteilen. Mit diesem Bike kannst du einfach nicht langsam fahren. Ready for racing!

A long-distance racer of superlatives! Our super lightweight carbon frame features the best components. Fox fork with Kashima coating, Shimano XTR groupset and Ritchey WCS carbon components. This bike makes it simply impossible to go slow. Ready for racing!

ACTIVE FLEX
SEAT STAY

SCL SPECIFIC
CHAINSTAY LENGTH

MIMS



	HTX 29 HM Carbon MIMS AFT SCL		Shimano XTR 42-32-24
	Ritchey WCS 31.8 mm		Magura MT8 Disc 180 mm
	FOX Forx 32F 29 Air FIT CTD Remote 100 mm Kashima Tapered 15 QR		Schwalbe Rocket Ron 2.25
	FSA Tapered		Schwalbe Rocket Ron 2.25
	Ritchey WCS Carbon UD Flat 660 mm 9 D 31.8 mm		Easton EA 70 XCT Wheelset
	Ritchey WCS Carbon Monolink 27.2 mm		Easton EA 70 XCT Wheelset
	Selle Italia SLR Monolink XP		Easton EA 70 XCT Wheelset
	Shimano XTR 10-Speed		Shimano XTR 11-34
	Shimano XTR		100 mm
	Shimano XTR SL		
	Magura MT8		40/44/48/52/56 cm
	Shimano Pressfit BB		9.40 kg

HTX LECTOR 2977

BLACK / GREY / BLUE



- | | | | |
|---|---|--|---|
|  HTX 29 HM Carbon MIMS AFT SCL |  Selle Royal Seta |  Shimano XT Disc 180 mm |  100 mm |
|  GHOST light AS-029 31.8 mm |  Shimano XT 10-Speed |  Schwalbe Rocket Ron 2.25 |  100 mm |
|  FOX Forx 32F 29 Air CTD Remote 100 mm Tapered 15 QR |  Shimano XT |  Schwalbe Rocket Ron 2.25 |  40/44/48/52/56 cm |
|  FSA Tapered |  Shimano XT SL |  Alex XD Sport |  kg 10,90 kg |
|  GHOST Flat light 680 mm 31.8 mm |  Shimano XT |  DT Swiss 1.8 | |
|  GHOST SL SP 717 27.2 mm |  Shimano Pressfit BB |  Shimano XT | |
| |  Shimano XT 42-32-24 |  SRAM PG-1030 11-36 | |

HTX LECTOR 2955

BLACK / GREY / WHITE







- | | | | |
|---|--|---|---|
|  HTX 29 HM Carbon MIMS AFT SCL |  Selle Royal Seta |  Avid Elixir 1 Disc 180 mm |  100 mm |
|  GHOST light AS-029 31.8 mm |  Shimano XT 10-Speed |  Schwalbe Rocket Ron 2.25 |  100 mm |
|  Rock Shox Reba 29 RL Solo Air PopLoc 100 mm Tapered |  Shimano SLX |  Schwalbe Rocket Ron 2.25 |  40/44/48/52/56 cm |
|  FSA Tapered |  Shimano Deore SL |  Ryde Taurus |  kg 11,20 kg |
|  GHOST flat bar super light 680 mm 31.8 mm |  Avid Elixir 1 |  DT Swiss 1.8 | |
|  GHOST SL SP 717 27.2 mm |  Shimano Pressfit BB |  Shimano Deore | |
| |  Shimano FCM 552 42-32-24 |  SRAM PG-1030 11-36 | |

HTX ACTINUM 2975



BLACK / WHITE / LIME GREEN



-  HTX 29 Actinum AFT SCL
-  GHOST light AS-029 31.8 mm
-  FOX Forx 32F 29 Air CTD Remote 100 mm Tapered 15 QR
-  Ritchey Tapered
-  GHOST Flat light 680 mm 31.8 mm
-  GHOST SL SP 717 27.2 mm

-  Selle Royal Seta
-  Shimano XT 10-Speed
-  Shimano XT
-  Shimano XT SL
-  Shimano XT
-  Shimano Pressfit BB
-  Shimano XT 42-32-24

-  Shimano XT Disc 180 mm
-  Schwalbe Rocket Ron 2.25
-  Schwalbe Rocket Ron 2.25
-  Alex XD Sport
-  DT Swiss 1.8
-  Shimano XT
-  SRAM PG-1030 11-36

-  100 mm
-  40/44/48/52/56 cm
-  kg 11.60 kg

HTX ACTINUM 2972

SILVER / WHITE / GREY



-  HTX 29 Actinum AFT SCL
-  GHOST light AS-029 31.8 mm
-  Rock Shox Reba 29 RL Solo Air PopLoc 100 mm Tapered
-  Ritchey Tapered
-  GHOST flat bar super light 680 mm 31.8 mm
-  GHOST SL SP 717 27.2 mm

-  Selle Royal Seta
-  Shimano XT 10-Speed
-  Shimano SLX
-  Shimano Deore SL
-  Avid Elixir 1
-  Shimano Pressfit BB
-  Shimano XT 42-32-24

-  Avid Elixir 1 Disc 180 mm
-  Schwalbe Rocket Ron 2.25
-  Schwalbe Rocket Ron 2.25
-  Ryde Taurus
-  DT Swiss 1.8
-  Shimano Deore
-  SRAM PG-1030 11-36

-  100 mm
-  40/44/48/52/56 cm
-  kg 11.90 kg

HTX LECTOR PRO TEAM

BLACK / GREY / RED



Dieses Bike ist das Arbeitsgerät unserer Profis: ultraleichter Carbonrahmen aus Hochmodulfasern, Sram XX-Gruppe, Tune und Ritchey WCS Superlogic-Anbauteile und Rock Shox SID XX Gabel stellen das traumhafte Gewicht dieser Rennmaschine sicher. Nur das Beste war gut genug für dieses Bike! Gebaut für Podestplätze auf der ganzen Welt.

This bicycle is the working tool of our professionals: The ultra-lightweight carbon frame made of high-modulus fibers, the Sram XX group, Tune and Ritchey WCS Superlogic components and Rock Shox SID XX fork ensure the fantastically low dream weight of this race machine. Only the best was good enough for this bike! Built for podium spots all over the world.

ACTIVE FLEX
SEAT STAY

SCL SPECIFIC
CHAINSTAY LENGTH

MIMS



reddot design award
winner 2011



Focus Open
Silver 2011



	HTX UHM Carbon MIMS AFT SCL		Avid XX Disc 180/160 mm
	Ritchey WCS 31.8 mm		Schwalbe Rocket Ron 2.25
	Rock Shox SID Air XX 100 mm Tapered		Schwalbe Rocket Ron 2.25
	Ritchey WCS Tapered		Tune King-Kong Dreckschleuder Wheelset
	Ritchey WCS Carbon UD Flat 660 mm 9 D 31.8 mm		Tune King-Kong Dreckschleuder Wheelset
	Ritchey WCS Carbon Monolink 27.2 mm		Tune King-Kong Dreckschleuder Wheelset
	Selle Italia SLR Monolink XP		SRAM XX 11-36
	SRAM XX 10-Speed		100 mm
	SRAM XX		100 mm
	SRAM XX Trigger		40/44/48/52/56 cm
	Avid XX		8.40 kg
	SRAM Pressfit BB		
	Truvativ XX 39-26		

HTX LECTOR 7700

BLACK / GREY / BLUE



- | | | | |
|--|---|--|---|
|  HTX HM Carbon MIMS AFT SCL |  Selle Royal Seta |  Shimano XT Disc 180 mm |  100 mm |
|  GHOST light AS-029 31.8 mm |  Shimano XT 10-Speed |  Schwalbe Rocket Ron 2.25 |  40/44/48/52/56 cm |
|  Rock Shox Reba RL Solo Air PopLoc
100 mm Tapered |  Shimano XT SL |  Alex XD Pro |  kg 10.30 kg |
|  Ritchey Tapered |  Shimano XT |  DT Swiss 1.8 | |
|  GHOST Low Rizer light 660 mm 31.8 mm |  Shimano Pressfit BB |  Shimano XT | |
|  GHOST SL SP 717 27.2 mm |  Shimano XT 42-32-24 |  Shimano XT 11-34 | |

HTX ACTINUM 7500

BLACK / WHITE / LIME GREEN























- | | | | |
|---|---|--|---|
|  HTX Actinum AFT SCL |  Selle Royal Seta |  Shimano XT Disc 180 mm |  100 mm |
|  GHOST light AS-029 31.8 mm |  Shimano XT 10-Speed |  Schwalbe Rocket Ron 2.25 |  40/44/48/52/56 cm |
|  Rock Shox Reba RL Solo Air PopLoc
100 mm Tapered |  Shimano XT SL |  Alex XD Pro |  kg 10.90 kg |
|  Ritchey Tapered |  Shimano XT |  DT Swiss 1.8 | |
|  GHOST Low Rizer light 660 mm 31.8 mm |  Shimano Pressfit BB |  Shimano XT | |
|  GHOST SL SP 717 27.2 mm |  Shimano XT 42-32-24 |  Shimano XT 11-34 | |

HTX ACTINUM 7200

SILVER / WHITE / GREY



- | | | | |
|---|---|---|---|
|  HTX Actinum AFT SCL |  Selle Royal Seta |  Avid Elixir 1 Disc 180 mm |  100 mm |
|  GHOST light AS-029 31.8 mm |  Shimano XT 10-Speed |  Schwalbe Rocket Ron 2.25 |  40/44/48/52/56 cm |
|  Rock Shox Reba RL Solo Air PopLoc
100 mm Tapered |  Shimano SLX |  Schwalbe Rocket Ron 2.25 |  11.30 kg |
|  Ritchey Tapered |  Shimano Deore SL |  Alex XD Pro | |
|  GHOST Low Rizer light 660 mm 31.8 mm |  Avid Elixir 1 |  DT Swiss 1.8 | |
|  GHOST SL SP 717 27.2 mm |  Shimano Pressfit BB |  Shimano Deore | |
| |  Shimano XT 42-32-24 |  SRAM PG-1030 11-36 | |



SE

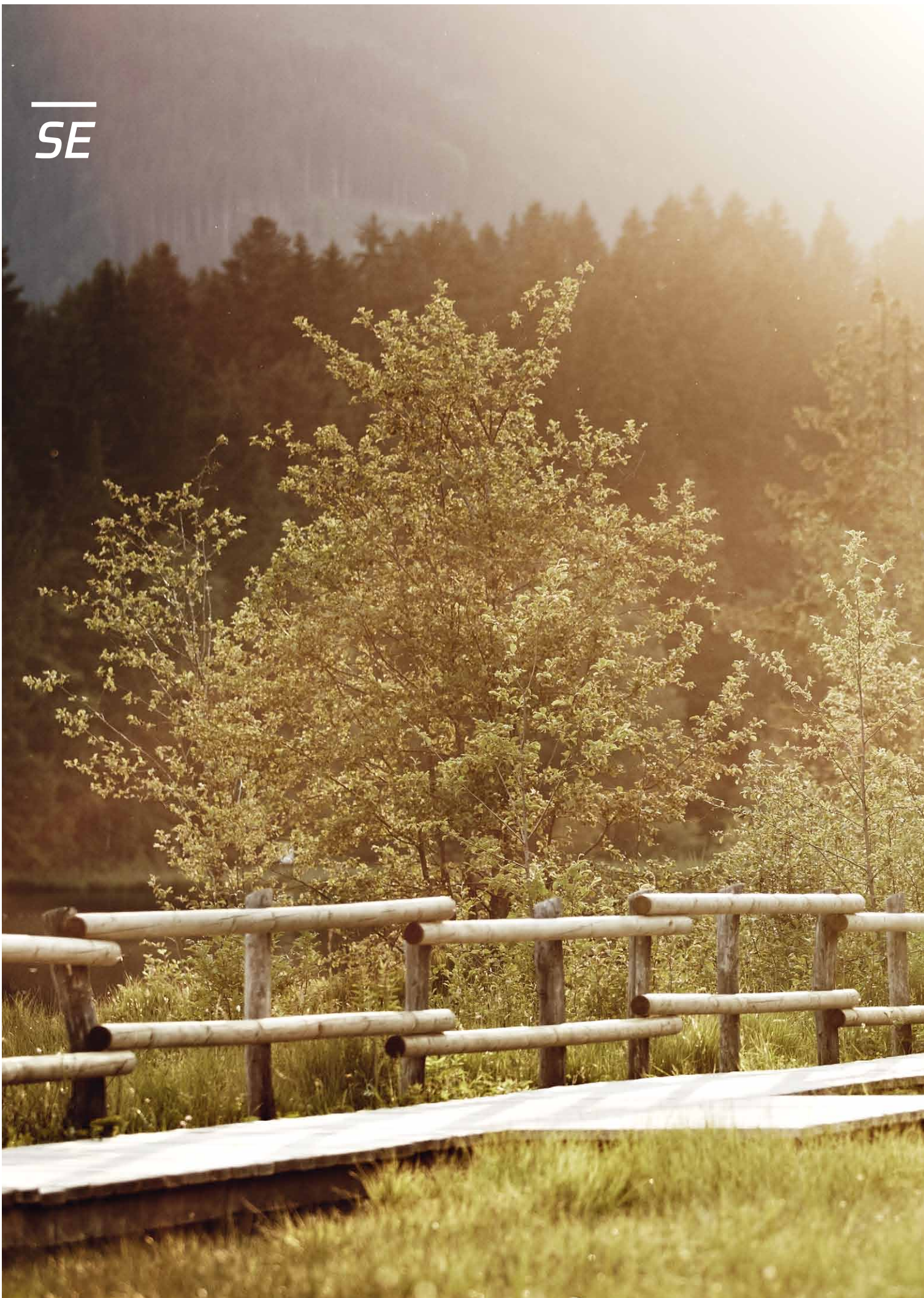



Schon den ganzen Tag freut ihr euch auf die Feierabendrunde mit eurem SE. Bei einer entspannten Tour lasst ihr den Tag bei den letzten Sonnenstrahlen ausklingen.

Dank der leichten Alurahmen in Kombination mit bewährten Anbauteilen, könnt ihr eure Runde unbeschwert genießen.

All day long, you have been looking forward to your after-work ride on your SE. You let the day come to a relaxing close as you enjoy the last rays of sunshine.

Thanks to the lightweight aluminum frame in combination with proven components, you can enjoy your ride worry-free.

SE 2990

BLACK / GREY / RED



Das SE 29 Topmodell hat alles, was ein Hardtail der Extraklasse aus Aluminium braucht: 100mm Rock Shox Reba RL Federgabel, Avid Elixir Scheibenbremsen und einen Shimano SLX/XT Antrieb, so dass ihr nach erfolgreicher Gipfelstürmung auch aufkommende Singletrail-Hürden mühelos nehmen könnt.























The SE 29 top model line has got everything a premium-class aluminum hardtail needs: 100mm Rock Shox Reba RL suspension fork, Avid Elixir disc brakes and a Shimano SLX/XT drivetrain. After conquering the summits, taking the single trail obstacles will be just as effortless.

THT | TAPERED HEAD TUBE

PM DIRECT

HYDROFORMING TUBESET



	SE 29 7005 DB		Avid Elixir 1 Disc 180 mm
	GHOST light AS-007N 31.8 mm		Schwalbe Rocket Ron 2.25
	Rock Shox Reba 29 RL Solo Air PopLoc 100 mm Tapered		Schwalbe Rocket Ron 2.25
	Ritchey Tapered		Ryde Taurus
	GHOST Flat light 680 mm 31.8 mm		DT Swiss 1.8
	GHOST light SP DC 1 27.2 mm		Shimano Deore
	GHOST VL 1535		SRAM PG-1030 11-36
	Shimano XT 10-Speed		100 mm
	Shimano SLX		100 mm
	Shimano SLX SL		40/44/48/52/56 cm
	Avid Elixir 1		12.90 kg
	Shimano BB51 BSA		
	Shimano SLX 42-32-24		

SE 2970

LIGHT GREY / WHITE / GREY



- | | | | |
|--|--|--|--|
|  SE 29 7005 DB |  GHOST VL 1535 |  Shimano 395 Disc 180 mm |  100 mm |
|  GHOST light AS-007N 31.8 mm |  Shimano XT 10-Speed |  Schwalbe Smart Sam 29 2.1 |  100 mm |
|  Rock Shox XC 32 Solo Air 29 PopLoc 100 mm Tapered |  Shimano SLX |  Schwalbe Smart Sam 29 2.1 |  40/44/48/52/56 cm |
|  Ritchey Tapered |  Shimano SLX SL |  Ryde Taurus |  kg 13.30 kg |
|  GHOST Flat light 680 mm 31.8 mm |  Shimano 395 |  DT Swiss 1.8 | |
|  GHOST light SP DC 1 27.2 mm |  Shimano BB51 BSA |  Shimano 435 | |
| |  Shimano FCM 552 42-32-24 |  SRAM PG-1030 11-36 | |

SE 2970

BLACK / GREY / BLUE

























- | | | | |
|---|--|---|---|
|  SE 29 7005 DB |  GHOST VL 1535 |  Shimano 395 Disc 180 mm |  100 mm |
|  GHOST light AS-007N 31.8 mm |  Shimano XT 10-Speed |  Schwalbe Smart Sam 29 2.1 |  100 mm |
|  Rock Shox XC 32 Solo Air 29 PopLoc 100 mm Tapered |  Shimano SLX |  Schwalbe Smart Sam 29 2.1 |  40/44/48/52/56 cm |
|  Ritchey Tapered |  Shimano SLX SL |  Ryde Taurus |  kg 13.30 kg |
|  GHOST Flat light 680 mm 31.8 mm |  Shimano 395 |  DT Swiss 1.8 | |
|  GHOST light SP DC 1 27.2 mm |  Shimano BB51 BSA |  Shimano 435 | |
| |  Shimano FCM 552 42-32-24 |  SRAM PG-1030 11-36 | |

SE 2950

BLACK / WHITE / GREEN

























 SE 29 7005 DB	 Shimano XT 10-Speed	 Schwalbe Smart Sam 29 2.1	 100 mm
 GHOST light A5-007N 31.8 mm	 Shimano SLX	 Schwalbe Smart Sam 29 2.1	 40/44/48/52/56 cm
 Suntour Raidon 29 AIR RL 100 mm	 Shimano Deore SL	 Ryde Taurus	 kg 14.70 kg
 FSA Gravity Taper	 Tektro HDC 300	 DT Swiss 1.8	
 GHOST Flat light 680 mm 31.8 mm	 Shimano BBES-25	 SRAM 306	
 GHOST light SP DC 1 27.2 mm	 Shimano FCM 522 42-34-24	 SRAM PG-1030 11-36	
 GHOST VL 1535			

SE 2950

BLACK / GREY / RED











 SE 29 7005 DB	 Shimano XT 10-Speed	 Schwalbe Smart Sam 29 2.1	 100 mm
 GHOST light A5-007N 31.8 mm	 Shimano SLX	 Schwalbe Smart Sam 29 2.1	 40/44/48/52/56 cm
 Suntour Raidon 29 AIR RL 100 mm	 Shimano Deore SL	 Ryde Taurus	 kg 14.70 kg
 FSA Gravity Taper	 Tektro HDC 300	 DT Swiss 1.8	
 GHOST Flat light 680 mm 31.8 mm	 Shimano BBES-25	 SRAM 306	
 GHOST light SP DC 1 27.2 mm	 Shimano FCM 522 42-34-24	 SRAM PG-1030 11-36	
 GHOST VL 1535			

SE 2930

BLACK / GREY / WHITE

























 SE 29 7005 DB	 Shimano XT 9-Speed	 Schwalbe Smart Sam 29 2.1	 100 mm
 Suntour SF13-XCM 29 RL 100 mm	 Shimano SLX	 Schwalbe Smart Sam 29 2.1	 40/44/48/52/56 cm
 FSA Gravity Taper	 Shimano Acera SL	 Ryde Taurus	 kg 14.50 kg
 GHOST flat bar super light 680 mm 31.8 mm	 Tektro HDC 300	 DT Swiss 1.8	
 GHOST light SP DC 1 27.2 mm	 Shimano BBES-25	 SRAM 306	
 GHOST VL 1535	 Shimano FCM 430 44-32-22	 SRAM PG-950 11-32	
	 Tektro HDC 300 Disc 180 mm		

SE 2920

LIGHT GREY / GREY / LIME GREEN























 SE 29 7005 DB	 Shimano Alivio 9-Speed	 Schwalbe Smart Sam 29 2.1	 100 mm
 Suntour SF13-XCM 29 MLO 100 mm	 Shimano SLX	 Schwalbe Smart Sam 29 2.1	 40/44/48/52/56 cm
 FSA Gravity Taper	 Shimano Acera SL	 Ryde Taurus	 kg 14.70 kg
 GHOST Flat light 680 mm 31.8 mm	 Tektro HDC 300	 DT Swiss 1.8	
 GHOST light SP DC 1 27.2 mm	 Shimano BBES-25	 SRAM 306	
 GHOST VL 1535	 Shimano Acera 44-32-22	 SRAM PG-950 11-32	
	 Tektro HDC 300 Disc 180 mm		

SE 2920

BLACK / GREY / GREY



- | | | | |
|---|--|---|---|
|  SE 29 7005 DB |  Shimano Alivio 9-Speed |  Schwalbe Smart Sam 29 2.1 |  100 mm |
|  GHOST light AS-007N 31.8 mm |  Shimano SLX |  Schwalbe Smart Sam 29 2.1 |  40/44/48/52/56 cm |
|  Suntour SF13-XCM 29 MLD 100 mm |  Shimano Acera SL |  Ryde Taurus |  kg 14.70 kg |
|  FSA Gravity Taper |  Tektro HDC 300 |  DT Swiss 1.8 | |
|  GHOST Flat light 680 mm 31.8 mm |  Shimano BBES-25 |  SRAM 306 | |
|  GHOST light SP DC 1 27.2 mm |  Shimano Acera 44-32-22 |  SRAM PG-950 11-32 | |
|  GHOST VL 1535 |  Tektro HDC 300 Disc 180 mm |  | |



SE 9000

BLACK / GREY / RED



Der Supersportler in der SE-Palette. Unser neu entwickelter Alurahmen mit allen technischen Raffinessen wie Pressfit-Innenlager und tapered Headtube dazu Shimano XT 30-Gang-Schaltung und eine Rock Shox Reba Luftgabel mit Lenker-Lockout! Spaß und Vortrieb der Extraklasse sind auf jeder Tour garantiert!

The ultra-athlete in the SE series. Our newly developed aluminum frame with fine technical details like Pressfit inner bearings and tapered headtube, Shimano XT 30-speed drivetrain and a Rock Shox Reba air suspension fork with handlebar lock-out! Premium-class fun and propulsion are guaranteed on all your tours!

THT | TAPERED HEAD TUBE

PM DIRECT

HYDROFORMING TUBESET



























	SE 7005 DB		Shimano 445 Disc 180 mm
	GHOST light AS-007N 31.8 mm		Schwalbe Racing Ralph 2.25
	Rock Shox Reba RL Solo Air PopLoc 100 mm Tapered		Schwalbe Racing Ralph 2.25
	Ritchey Tapered		Alex XD Sport
	GHOST Low Rizer light 660 mm 31.8 mm		DT Swiss 1.8
	GHOST light SP DC 1 27.2 mm		Shimano 435
	GHOST VL 1535		SRAM PG-1030 11-36
	Shimano XT 10-Speed		100 mm
	Shimano SLX		100 mm
	Shimano SLX SL		40/44/48/52/56 cm
	Shimano 445		kg 11.90 kg
	Shimano BB51 BSA		
	Shimano SLX 42-32-24		

SE 8000

BLACK / GREY / LIME GREEN



























 SE 7005 DB	 Shimano XT 10-Speed	 Schwalbe Smart Sam 2.1	 100 mm
 GHOST light AS-007N 31.8 mm	 Shimano SLX	 Schwalbe Smart Sam 2.1	
 Rock Shox Recon Silver Air PopLoc 100 mm	 Shimano Deore SL	 Alex XD Sport	 34/40/44/48/52/56 cm
 FSA Gravity Taper	 Shimano 445	 DT Swiss 1.8	 kg 12.40 kg
 GHOST Low Rizer light 660 mm 31.8 mm	 Shimano BB51 BSA	 Shimano 435	
 GHOST light SP DC 1 27.2 mm	 Shimano FCM 552 42-32-24	 SRAM PG-1030 11-36	
 GHOST VL 1535	 Shimano 445 Disc 180 mm		

SE 5000

BLACK / GREY / RED

























 SE 7005 DB	 Shimano XT 10-Speed	 Schwalbe Smart Sam 2.1	 100 mm
 GHOST light AS-007N 31.8 mm	 Shimano Deore	 Schwalbe Smart Sam 2.1	
 RST First 32 Air GSRL 100 mm	 Shimano Deore SL	 Alex XD Sport	 34/40/44/48/52/56 cm
 FSA Gravity Taper	 Shimano 395	 DT Swiss 1.8	 kg 12.60 kg
 GHOST Low Rizer light 660 mm 31.8 mm	 Shimano BB51 BSA	 Shimano	
 GHOST light SP DC 1 27.2 mm	 Shimano FCM 552 42-32-24	 SRAM PG-1030 11-36	
 GHOST VL 1535	 Shimano 395 Disc 180 mm		

SE 5000

GREY / GREY / LIME GREEN

























 SE 7005 DB	 Shimano XT 10-Speed	 Schwalbe Smart Sam 2.1	 100 mm
 GHOST light A5-007N 31.8 mm	 Shimano Deore	 Schwalbe Smart Sam 2.1	 34/40/44/48/52/56 cm
 RST First 32 Air G5RL 100 mm	 Shimano Deore SL	 Alex XD Sport	 12.60 kg
 FSA Gravity Taper	 Shimano 395	 DT Swiss 1.8	
 GHOST Low Rizer light 660 mm 31.8 mm	 Shimano BB51 BSA	 Shimano	
 GHOST light SP DC 1 27.2 mm	 Shimano FCM 552 42-32-24	 SRAM PG-1030 11-36	
 GHOST VL 1535	 Shimano 395 Disc 180 mm		

SE 4000

GREY / WHITE / GREY



























 SE 7005 DB	 Shimano XT 10-Speed	 Schwalbe Smart Sam 2.1	 100 mm
 GHOST light A5-007N 31.8 mm	 Shimano Deore	 Schwalbe Smart Sam 2.1	 34/40/44/48/52/56 cm
 Suntour Raidon AIR RL 100 mm	 Shimano Deore SL	 Alex XD Sport	 12.90 kg
 Ritchey	 Tektro HDC 300	 DT Swiss 1.8	
 GHOST Low Rizer light 660 mm 31.8 mm	 Shimano BBES-25	 SRAM 306	
 GHOST light SP DC 1 31.6 mm	 Shimano FCM 522 42-34-24	 SRAM PG-1030 11-36	
 GHOST VL 1535	 Tektro HDC 300 Disc 160 mm		

SE 4000

BLACK / GREY / BLUE



 SE 7005 DB	 Shimano XT 10-Speed	 Schwalbe Smart Sam 2.1	 100 mm
 GHOST light AS-007N 31.8 mm	 Shimano Deore	 Schwalbe Smart Sam 2.1	 34/40/44/48/52/56 cm
 Suntour Raidon AIR RL 100 mm	 Shimano Deore SL	 Alex XD Sport	 kg 12.90 kg
 Ritchey	 Tektro HDC 300	 DT Swiss 1.8	
 GHOST Low Rizer light 660 mm 31.8 mm	 Shimano BBES-25	 SRAM 306	
 GHOST light SP DC 1 31.6 mm	 Shimano FCM 522 42-34-24	 SRAM PG-1030 11-36	
 GHOST VL 1535	 Tektro HDC 300 Disc 160 mm		

SE 3000

BLACK / GREY / WHITE



























 SE 7005 DB	 Shimano XT 9-Speed	 Schwalbe Smart Sam 2.1	 100 mm
 GHOST light AS-007N 31.8 mm	 Shimano Alivio	 Schwalbe Smart Sam 2.1	 34/40/44/48/52/56 cm
 Suntour XCM RL 100 mm	 Shimano Acera SL	 Ryde Taurus	 kg 13.50 kg
 Ritchey	 Tektro HDC 300	 DT Swiss 1.8	
 GHOST Low Rizer light 660 mm 31.8 mm	 Shimano BBES-25	 SRAM 306	
 GHOST light SP DC 1 31.6 mm	 Shimano FCM 430 44-32-22	 SRAM PG-950 11-32	
 GHOST VL 1535	 Tektro HDC 300 Disc 160 mm		

SE 3000

BLACK / WHITE / RED



























 SE 7005 DB	 Shimano XT 9-Speed	 Schwalbe Smart Sam 2.1	 100 mm
 GHOST light AS-007N 31.8 mm	 Shimano Alivio	 Schwalbe Smart Sam 2.1	 34/40/44/48/52/56 cm
 Suntour XCM RL 100 mm	 Shimano Acera SL	 Ryde Taurus	 13.50 kg
 Ritchey	 Tektro HDC 300	 DT Swiss 1.8	
 GHOST Low Rizer light 660 mm 31.8 mm	 Shimano BBES-25	 SRAM 306	
 GHOST light SP DC 1 31.6 mm	 Shimano FCM 430 44-32-22	 SRAM PG-950 11-32	
 GHOST VL 1535	 Tektro HDC 300 Disc 160 mm		

SE 2000

BLACK / GREY / RED

























 SE 7005 PG	 Shimano Deore 9-Speed	 Schwalbe Smart Sam 2.1	 100 mm
 GHOST light AS-007N 31.8 mm	 Shimano Acera	 Schwalbe Smart Sam 2.1	 34/40/44/48/52/56 cm
 Suntour SF13-XCM MLO 100 mm	 Shimano Acera SL	 Ryde Taurus	 13.70 kg
 Ritchey	 Tektro HDC 300	 DT Swiss 1.8	
 GHOST Low Rizer light 640 mm 31.8 mm	 Shimano BBES-25	 SRAM 306	
 GHOST light SP DC 1 31.6 mm	 Shimano Acera 44-32-22	 Shimano 11-32	
 GHOST VL 1535	 Tektro HDC 300 Disc 160 mm		

SE 2000

GREY / WHITE / LIME GREEN

























 SE 7005 PG	 Shimano Deore 9-Speed	 Schwalbe Smart Sam 2.1	 100 mm
 GHOST light AS-007N 31.8 mm	 Shimano Acera	 Schwalbe Smart Sam 2.1	 34/40/44/48/52/56 cm
 Suntour SF13-XCM MLO 100 mm	 Shimano Acera SL	 Ryde Taurus	 kg 13.70 kg
 Ritchey	 Tektro HDC 300	 DT Swiss 1.8	
 GHOST Low Rizer light 640 mm 31.8 mm	 Shimano BBES-25	 SRAM 306	
 GHOST light SP DC 1 31.6 mm	 Shimano Acera 44-32-22	 Shimano 11-32	
 GHOST VL 1535	 Tektro HDC 300 Disc 160 mm		

SE 1800

BLACK / GREY / WHITE



 SE 7005 PG	 Shimano Alivio 9-Speed	 Impac Ridgepac 2.1	 100 mm
 GHOST light AS-007N 31.8 mm	 Shimano Acera	 Impac Ridgepac 2.1	 34/40/44/48/52/56 cm
 RST Gila MLO 100 mm	 Shimano Acera SL	 Ryde Zac Pro	 kg 13.00 kg
 Ritchey	 Shimano Acera SL	 DT Swiss 1.8	
 GHOST Low Rizer light 640 mm 31.8 mm	 Shimano BBES-25	 Shimano	
 GHOST light SP DC 1 31.6 mm	 Shimano Acera 44-32-22	 Shimano 11-32	
 GHOST VL 1535	 Shimano V-Brake		

SE 1800

WHITE / BLACK / RED

























 SE 7005 PG	 Shimano Alivio 9-Speed	 Impac Ridgepac 2.1	 100 mm
 GHOST light A5-007N 31.8 mm	 Shimano Acera	 Impac Ridgepac 2.1	 34/40/44/48/52/56 cm
 RST Gila MLO 100 mm	 Shimano Acera SL	 Ryde Zac Pro	 kg 13.00 kg
 Ritchey	 Shimano Acera SL	 DT Swiss 1.8	
 GHOST Low Rizer light 640 mm 31.8 mm	 Shimano BBES-25	 Shimano	
 GHOST light SP DC 1 31.6 mm	 Shimano Acera 44-32-22	 Shimano 11-32	
 GHOST VL 1535	 Shimano V-Brake		

SE 1300

BLACK / GREY / BLUE









 SE 7005 PG	 Shimano Acera 8-Speed	 Impac Ridgepac 2.1	 100 mm
 GHOST light A5-007N 31.8 mm	 Shimano	 Impac Ridgepac 2.1	 34/40/44/48/52/56 cm
 RST Gila MLO 100 mm	 Shimano Acera STI	 Ryde Zac Pro	 kg 13.10 kg
 Ritchey	 Shimano Acera STI	 DT Swiss 1.8	
 GHOST Low Rizer light 640 mm 31.8 mm	 Shimano BBUN-26	 Shimano	
 GHOST light SP DC 1 31.6 mm	 Shimano FCM 171 42-34-24	 SRAM PG-820 11-30	
 GHOST VL 1535	 Tektro V-Brake		







SE 1300





GREY / BLUE / LIME GREEN



-  SE 7005 PG
-  GHOST light AS-007N 31.8 mm
-  RST Gila MLO 100 mm
-  Ritchey
-  GHOST Low Rizer light 640 mm 31.8 mm
-  GHOST light SP DC 1 31.6 mm
-  GHOST VL 1535

-  Shimano Acera 8-Speed
-  Shimano
-  Shimano Acera STI
-  Shimano Acera STI
-  Shimano BBUN-26
-  Shimano FCM 171 42-34-24
-  Tektro V-Brake

-  Impac Ridgepac 2.1
-  Impac Ridgepac 2.1
-  Ryde Zac Pro
-  DT Swiss 1.8
-  Shimano
-  SRAM PG-820 11-30







-  100 mm
- 
-  34/40/44/48/52/56 cm
-  kg 13.10 kg







SE 1200





GREY / BLACK / LIME GREEN



-  SE 7005 PG
-  GHOST light AS-007N 31.8 mm
-  Suntour XCT PL 100 mm
-  Ritchey
-  GHOST Low Rizer light 640 mm 31.8 mm
-  GHOST light SP DC 1 31.6 mm
-  GHOST VL 1535

-  Shimano Altus 8-Speed
-  Shimano
-  Shimano Altus STI
-  Shimano Altus STI
-  Shimano BBUN-26
-  Shimano FCM 171 42-34-24
-  Tektro V-Brake

-  Impac Ridgepac 2.1
-  Impac Ridgepac 2.1
-  Ryde Zac Pro
-  DT Swiss 1.8
-  Shimano
-  SRAM PG-820 11-30

-  100 mm
- 
-  34/40/44/48/52/56 cm
-  kg 13.20 kg

SE 1200

GREEN / WHITE / BLUE



- | | | | |
|--|--|---|--|
|  SE 7005 PG |  Shimano Altus 8-Speed |  Impac Ridgepac 2.1 |  100 mm |
|  GHOST light A5-007N 31.8 mm |  Shimano |  Impac Ridgepac 2.1 |  34/40/44/48/52/56 cm |
|  Suntour XCT PL 100 mm |  Shimano Altus STI |  Ryde Zac Pro |  kg 13.20 kg |
|  Ritchey |  Shimano Altus STI |  DT Swiss 1.8 | |
|  GHOST Low Rizer light 640 mm 31.8 mm |  Shimano BBUN-26 |  Shimano | |
|  GHOST light SP DC 1 31.6 mm |  Shimano FCM 171 42-34-24 |  SRAM PG-820 11-30 | |
|  GHOST VL 1535 |  Tektro V-Brake | | |



DIRT / 4CROSS





Riders ready, watch the gate. Alles oder nichts. Jetzt kommt es auf dich und dein Bike an. Nachdem das Gatter gefallen ist, folgen explosive Sprints und weite Sprünge. Kannst du die Führung bis in Ziel verteidigen? Go fast - or last.

Riders ready, watch the gate. All or nothing. Now, it is all up to you and your bike. After the gate drops, the race is about explosive sprints and long jumps. Can you defend your lead until the finish line? Go fast - or last.

DIRT PRO

RAW / YELLOW / GREEN



Ein Styler der Extraklasse. Schwerste Moves sehen mit diesem Bike extrem lässig aus. Unseren Dirt Frame aus Alu haben wir mit superstabilen Komponenten bestückt. Dirtline, Cityspot oder Pumptrack, dieses Bike ist der perfekte Begleiter. Zeig, was du drauf hast mit deinem Dirt!

A premium class style icon. This bike makes the most difficult moves seem effortless and cool. We equipped our Dirt aluminum frame with super robust components. Dirtline, city spot or pump track, this bike is your perfect companion wherever you go. Show what you've got with your Dirt!

THT | TAPERED HEAD TUBE

ISCG























	Dirt 7005 PG		Shimano ZEE Disc 160 mm
	GHOST 4X AS-020 31.8mm		Schwalbe Table Top Sport 2.25
	RST Space Jump 100 mm		Schwalbe Table Top Sport 2.25
	reducer		Alex Supra 4X
	GHOST Low Rizer light 640 mm 31.8 mm		DT Swiss 1.8
	PREMETEC		Joytech/Novatec
	GHOST VL 7081		Joytech/novatec single speed 18T
	Joytech/novatec single speed 18T		100 mm
			
	Shimano ZEE		32 cm
	Shimano BB BSA		12.40 kg
	Shimano ZEE 34		

DIRT COMP

RAW / BLUE / ORANGE



 Dirt 7005 PG	 Joytech/novatec single speed 18T	 Schwalbe Table Top Sport 2.25	 100 mm
 GHOST 4X AS-020 31.8mm	 Schwalbe Table Top Sport 2.25	 Ryde Taurus	 32 cm
 RST Space Free 100 mm	 Tektro HDC 300	 DT Swiss 1.8	 kg 13.40 kg
 reducer	 Truvativ Howitzer XR	 Joytech/Novatec	
 GHOST Low Rizer light 640 mm 31.8 mm	 Truvativ Ruktion 1.0 34	 Joytech/novatec single speed 18T	
 PREMETEC	 Tektro HDC 300 Disc 160 mm		
 GHOST VL 7081			

4-X TEAM

BLACK / GREEN / BLUE

VORJAHRESMODELL GETESTET
RATING FOR LAST YEARS MODEL

























 4-X 7005 DB Team	 GHOST VL 1411	 Shimano XT Disc 180 mm	 100 mm
 Truvativ Holzfeller 31.8 mm	 Shimano XT 10-Speed	 Schwalbe Nobby Nic 2.25	 36 cm
 Rock Shox Reba RL Dual Air 100 mm	 Shimano XT SL	 Alex SX 44 Disc	 kg 13.50 kg
 Ritchey Tapered	 Shimano XT	 DT Swiss 1.8	
 Truvativ Boobar 740mm 31.8 mm	 Shimano Pressfit BB	 Shimano XT	
 GHOST light SP 620 31.6 mm	 Shimano XT 38-26	 Shimano 105 11-28	

4X COMP

RAW / GREY / BLUE



 4-X 7005 PG	 Shimano Acera 8-Speed	 Schwalbe Table Top Sport 2.25	 100 mm
 GHOST 4X AS-020 31.8mm	 Shimano	 Schwalbe Table Top Sport 2.25	 38/42 cm
 RST Dirt T 100 mm	 Shimano Acera SL	 Ryde Taurus	 kg 14.10 kg
 Ritchey	 Tektro HDC 300	 DT Swiss 1.8	
 GHOST Low Rizer light 660 mm 31.8 mm	 Shimano BBUN-26	 SRAM 306	
 GHOST light SP DC 1 31.6 mm	 Shimano FCM 171 42-34-24	 Shimano 11-30	
 GHOST VL 1535	 Tektro HDC 300 Disc 160 mm		

4X COMP

GREY / WHITE / GREEN



 4-X 7005 PG	 Shimano Acera 8-Speed	 Schwalbe Table Top Sport 2.25	 100 mm
 GHOST 4X AS-020 31.8mm	 Shimano	 Schwalbe Table Top Sport 2.25	 38/42 cm
 RST Dirt T 100 mm	 Shimano Acera SL	 Ryde Taurus	 kg 14.10 kg
 Ritchey	 Tektro HDC 300	 DT Swiss 1.8	
 GHOST Low Rizer light 660 mm 31.8 mm	 Shimano BBUN-26	 SRAM 306	
 GHOST light SP DC 1 31.6 mm	 Shimano FCM 171 42-34-24	 Shimano 11-30	
 GHOST VL 1535	 Tektro HDC 300 Disc 160 mm		

MISS

Miss AMR

All Mountain Tour



All Mountain Trail

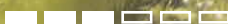

Miss Hardtail

Cross Country Tour



Marathon Tour



Miss RT

Cross Country Tour



Marathon Tour

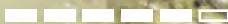



MISS AMR 7500

BLACK / GREY / TURQUOISE



Ein Traumbike für Frauen, die wissen, was sie wollen. Unser superleichter AMR 120mm Alurahmen, aufgebaut mit Fox Fahrwerk, Shimano XT-Ausstattung und leichten Anbauteilen. Freu dich über die perfekte Verbindung von niedrigem Gewicht, Zuverlässigkeit und Komfort. Das ist Miss AMR!

A dream bike for women who know what they want. Our super lightweight AMR 120mm aluminum frame features a Fox suspension chassis, Shimano XT equipment and lightweight components. Get excited about the perfect combination of low weight, reliability and comfort. This is called the Miss AMR!

M MISS STYLE
CONCEPT

SCL SPECIFIC
CHAINSTAY LENGTH

SMOOTH RATIO
SUSPENSION **2:1**



	AMR Actinum DB SCL		Shimano XT Disc 180 mm
	GHOST light ASA-106 31.8 mm		Schwalbe Nobby Nic 2.25
	FOX Forx 32F O/C CTD 120 mm Tapered 15QR		Schwalbe Nobby Nic 2.25
	Ritchey Tapered		Alex XD Pro
	GHOST Low Rizer light 680 mm 31.8 mm		DT Swiss 1.8
	GHOST SL SP 717 31.6 mm		Shimano XT
	GHOST VL 1535		Shimano XT 11-34
	Shimano XT 10-Speed		FOX Float CTD 120 mm Boost Valve
	Shimano XT		120 mm
	Shimano XT SL		120 mm
	Shimano XT		40/44/48/52 cm
	Shimano Pressfit BB		kg 12.40 kg
	Shimano XT 42-32-24		

MISS AMR 5700

LIGHT GREY / WHITE / LIME GREEN





 AMR Actinum DB SCL

 GHOST light ASA-106 31.8 mm

 FOX Forx 32F CTD O/C Evolution
120 mm Tapered

 Ritchey Tapered

 GHOST Low Rizer light 680 mm 31.8 mm

 GHOST SL SP 717 31.6 mm

 GHOST VL 1535

 Shimano XT 10-Speed

 Shimano SLX

 Shimano Deore SL

 Shimano 505

 Shimano Pressfit BB

 Shimano FCM 552 42-32-24

 Shimano 505 Disc 180 mm

 Schwalbe Nobby Nic 2.25

 Schwalbe Nobby Nic 2.25

 Alex XD Pro

 DT Swiss 1.8

 Shimano Deore

 SRAM PG-1030 11-36

 FOX Float CTD SV 120mm

 120 mm

 120 mm

 40/44/48/52 cm

 kg 12.60 kg

MISS RT 5500

BLACK / BLUE / SAND



 Miss RT Actinum DB

 GHOST light AS-007N 31.8 mm

 Rock Shox XC 32 Solo Air PopLoc
100 mm

 Ritchey Tapered

 GHOST Low Rizer light 640 mm 31.8 mm

 GHOST light SP DC 1 31.6 mm

 GHOST VL 4212 Lady

 Shimano XT 10-Speed

 Shimano SLX

 Shimano SLX SL

 Avid Elixir 3

 Shimano BB51 BSA

 Shimano XT 42-32-24

 Avid Elixir 3 Disc 180 mm

 Schwalbe Smart Sam 2.1

 Schwalbe Smart Sam 2.1

 Alex XD Sport

 DT Swiss 1.8

 SRAM 306

 SRAM PG-1030 11-36

 X-Fusion E1 Air RL 100 mm

 100 mm

 100 mm

























 40/44/48/52 cm

 kg 12.50 kg

MISS RT 5100

WHITE / GREY / LIME GREEN



























- | | | | |
|--|--|---|---|
|  Miss RT Actinum DB |  Shimano XT 10-Speed |  Schwalbe Smart Sam 2.1 |  100 mm |
|  GHOST light AS-007N 31.8 mm |  Shimano Deore |  Schwalbe Smart Sam 2.1 |  100 mm |
|  Suntour Raidon AIR RL 100 mm |  Shimano Deore SL |  Alex XD Sport |  40/44/48/52 cm |
|  Ritchey Tapered |  Tektro HDC 300 |  DT Swiss 1.8 |  kg 13.20 kg |
|  GHOST Low Rizer light 640 mm 31.8 mm |  Shimano BBES-25 |  SRAM 306 | |
|  GHOST light SP DC 1 31.6 mm |  Shimano FCM 552 42-34-24 |  SRAM PG-1030 11-36 | |
|  GHOST VL 4212 Lady |  Tektro HDC 300 Disc 160 mm |  X-Fusion E1 Air RL 100 mm | |

MISS 8000

GREY / BLACK / PETROL

























- | | | | |
|--|--|--|---|
|  Miss 7005 DB |  Shimano XT 10-Speed |  Schwalbe Smart Sam 2.1 |  100 mm |
|  GHOST light AS-007N 31.8 mm |  Shimano SLX |  Schwalbe Smart Sam 2.1 |  100 mm |
|  Rock Shox Recon Silver Air PopLoc 100 mm |  Shimano Deore SL |  Alex XD Sport |  34/40/44/48/52 cm |
|  Ritchey |  Shimano 445 |  DT Swiss 1.8 |  kg 12.60 kg |
|  GHOST Low Rizer light 640 mm 31.8 mm |  Shimano BB51 BSA |  Shimano 435 | |
|  GHOST light SP DC 1 31.6 mm |  Shimano FCM 552 42-32-24 |  SRAM PG-1030 11-36 | |
|  GHOST VL 4212 |  Shimano 445 Disc 180 mm | | |

MISS 5000

GREY / WHITE / GREEN

























 Miss 7005 DB	 Shimano XT 10-Speed	 Schwalbe Smart Sam 2.1	 100 mm
 GHOST light AS-007N 31.8 mm	 Shimano Deore	 Schwalbe Smart Sam 2.1	 34/40/44/48/52 cm
 RST First 32 Air GSRL 100 mm	 Shimano Deore SL	 Alex XD Sport	 12.60 kg
 Ritchey	 Shimano 395	 DT Swiss 1.8	
 GHOST Low Rizer light 640 mm 31.8 mm	 Shimano BB51 BSA	 Shimano	
 GHOST light SP DC 1 31.6 mm	 Shimano FCM 552 42-32-24	 SRAM PG-1030 11-36	
 GHOST VL 4212 Lady	 Shimano 395 Disc 180 mm		

MISS 3000

LIGHTGREY / WHITE / PETROL











 Miss 7005 DB	 Shimano XT 9-Speed	 Schwalbe Smart Sam 2.1	 100 mm
 GHOST light AS-007N 31.8 mm	 Shimano Alivio	 Schwalbe Smart Sam 2.1	 34/40/44/48/52 cm
 Suntour XCM RL 100 mm	 Shimano Acera SL	 Ryde Taurus	 13.50 kg
 Ritchey	 Tektro HDC 300	 DT Swiss 1.8	
 GHOST Low Rizer light 640 mm 31.8 mm	 Shimano BBES-25	 SRAM 306	
 GHOST light SP DC 1 31.6 mm	 Shimano FCM 430 44-32-22	 SRAM PG-950 11-32	
 GHOST VL 4212 Lady	 Tektro HDC 300 Disc 160 mm		

MISS 2000

WHITE / GREY / GREEN

























- | | | | |
|--|--|--|---|
|  Miss 7005 PG |  Shimano Deore 9-Speed |  Schwalbe Smart Sam 2.1 |  100 mm |
|  GHOST light A5-007N 31.8 mm |  Shimano Acera |  Schwalbe Smart Sam 2.1 |  34/40/44/48/52 cm |
|  Suntour XCM MLO 100 mm |  Shimano Acera SL |  Ryde Taurus |  kg 13.70 kg |
|  Ritchey |  Tektro HDC 300 |  DT Swiss 1.8 | |
|  GHOST Low Rizer light 640 mm 31.8 mm |  Shimano BBES-25 |  SRAM 306 | |
|  GHOST light SP DC 1 31.6 mm |  Shimano Acera 44-32-22 |  Shimano 11-32 | |
|  GHOST VL 4212 Lady |  Tektro HDC 300 Disc 160 mm | | |

MISS 2000

BLACK / GREY / PINK





















- | | | | |
|--|--|--|---|
|  Miss 7005 PG |  Shimano Deore 9-Speed |  Schwalbe Smart Sam 2.1 |  100 mm |
|  GHOST light A5-007N 31.8 mm |  Shimano Acera |  Schwalbe Smart Sam 2.1 |  34/40/44/48/52 cm |
|  Suntour XCM MLO 100 mm |  Shimano Acera SL |  Ryde Taurus |  kg 13.70 kg |
|  Ritchey |  Tektro HDC 300 |  DT Swiss 1.8 | |
|  GHOST Low Rizer light 640 mm 31.8 mm |  Shimano BBES-25 |  SRAM 306 | |
|  GHOST light SP DC 1 31.6 mm |  Shimano Acera 44-32-22 |  Shimano 11-32 | |
|  GHOST VL 4212 Lady |  Tektro HDC 300 Disc 160 mm | | |

MISS 1800

WHITE / BROWN / PETROL











- | | | | |
|--|--|--|---|
|  Miss 7005 PG |  Shimano Alivio 9-Speed |  Impac Ridgepac 2.1 |  100 mm |
|  GHOST light AS-007N 31.8 mm |  Shimano Acera |  Impac Ridgepac 2.1 |  34/40/44/48/52 cm |
|  RST Gila MLO 100 mm |  Shimano Acera SL |  Ryde Zac Pro |  kg 13.10 kg |
|  Ritchey |  Shimano V-Brake |  DT Swiss 1.8 | |
|  GHOST Low Rizer light 640 mm 31.8 mm |  Shimano BBES-25 |  Shimano | |
|  GHOST light SP DC 1 31.6 mm |  Shimano Acera 44-32-22 |  Shimano 11-32 | |
|  GHOST VL 4212 Lady |  Shimano V-Brake | | |

MISS 1800

GREY / GREEN / GREY

























- | | | | |
|--|--|--|---|
|  Miss 7005 PG |  Shimano Alivio 9-Speed |  Impac Ridgepac 2.1 |  100 mm |
|  GHOST light AS-007N 31.8 mm |  Shimano Acera |  Impac Ridgepac 2.1 |  34/40/44/48/52 cm |
|  RST Gila MLO 100 mm |  Shimano Acera SL |  Ryde Zac Pro |  kg 13.10 kg |
|  Ritchey |  Shimano V-Brake |  DT Swiss 1.8 | |
|  GHOST Low Rizer light 640 mm 31.8 mm |  Shimano BBES-25 |  Shimano | |
|  GHOST light SP DC 1 31.6 mm |  Shimano Acera 44-32-22 |  Shimano 11-32 | |
|  GHOST VL 4212 Lady |  Shimano V-Brake | | |

MISS 1200

WHITE / PURPLE / PINK

























- | | | | |
|--|--|---|---|
|  Miss 7005 PG |  Shimano Altus 8-Speed |  Impac Ridgepac 2.1 |  100 mm |
|  GHOST light A5-007N 31.8 mm |  Shimano |  Impac Ridgepac 2.1 |  34/40/44/48/52 cm |
|  Suntour XCT PL 100 mm |  Shimano Altus STI |  Ryde Zac Pro |  kg 13.20 kg |
|  Ritchey |  Shimano Altus STI |  DT Swiss 1.8 | |
|  GHOST Low Rizer light 640 mm 31.8 mm |  Shimano BBUN-26 |  Shimano | |
|  GHOST light SP DC 1 31.6 mm |  Shimano FCM 171 42-34-24 |  SRAM PG-820 11-30 | |
|  GHOST VL 4212 Lady |  Tektro V-Brake | | |

MISS 1200

GREY / BLUE / SAND



- | | | | |
|--|--|--|---|
|  Miss 7005 PG |  Shimano Altus 8-Speed |  Impac Ridgepac 2.1 |  100 mm |
|  GHOST light A5-007N 31.8 mm |  Shimano |  Impac Ridgepac 2.1 |  34/40/44/48/52 cm |
|  Suntour XCT PL 100 mm |  Shimano Altus STI |  Ryde Zac Pro |  kg 13.20 kg |
|  Ritchey |  Shimano Altus STI |  DT Swiss 1.8 | |
|  GHOST Low Rizer light 640 mm 31.8 mm |  Shimano BBUN-26 |  Shimano | |
|  GHOST light SP DC 1 31.6 mm |  Shimano FCM 171 42-34-24 |  SRAM PG-820 11-30 | |
|  GHOST VL 4212 Lady |  Tektro V-Brake | | |

PEDELECS



E-Hybride Trail

Tour



E-Hybride Cross

Tour

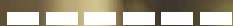

E-Hybride Trekking

City



Tour



E-Hybride Wave

City

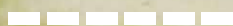

Tour

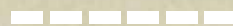



E-HYBRIDE TRAIL 9000

BLACK / WHITE / ORANGE



Gleite lautlos durch die Natur, genieße Steigungen ohne Anstrengung. Unser ION Elektroantrieb in der Hinterradnabe ist der perfekte Begleiter dafür. Ausgestattet mit Shimano XT 27-Gang-Schaltung, Fox-Federgabel und zuverlässigen Anbauteilen, ist dieses Bike der perfekte Begleiter auf jeder Tour. Hightech trifft auf pure Emotion!

Glide silently through nature. Enjoy climbs effortlessly. Our ION electric drive in the rear wheel hub is the perfect companion. Featuring a Shimano XT 27-speed drivetrain, Fox suspension fork and durable components, this bike is perfect for any tour. High Tech meets pure emotion!

ION ION TECHNOLOGY

BET:
BETTER ELECTRIC-BICYCLING TOURS

CONTINUOUS
CABLE HOUSING



	E-Hybride Trail		Shimano XT Disc 180/160 mm
	GHOST light AS-025 31.8 mm		Schwalbe Racing Ralph 2.10
	FOX Forx 32F O/C CTD 120 mm Tapered 15QR		Schwalbe Racing Ralph 2.10
	Ritchey Tapered		Ryde Andra 210
	GHOST Low Rizer light 680 mm 31.8 mm		Alpina F1-3 / DT Swiss 1.8
	GHOST SL SP 717 31.6 mm		Shimano XT
	GHOST VL 1376		SunRace 11-32
	Shimano XT 9-Speed		120 mm
	Shimano XT		120 mm
	Shimano XT		44/48/52 cm
	Shimano BB BSA		22.40 kg
	Shimano XT 44-32-22		motor: ION 250 W 40 Nm
			battery: Lithium Ion 360 Wh

E-HYBRIDE TRAIL 9000 LADY

BLACK / WHITE / AUBERGINE



























 E-Hybride Trail Lady	 Shimano XT 9-Speed	 Schwalbe Racing Ralph 2.10	 120 mm
 GHOST light AS-025 31.8 mm	 Shimano XT	 Schwalbe Racing Ralph 2.10	 44/48/52 cm
 FOX Forx 32F 0/C CTD 120 mm Tapered 15QR	 Shimano XT	 Ryde Andra 210	 kg 22.40 kg
 Ritchey Tapered	 Shimano XT	 Alpina F1-3 / DT Swiss 1.8	 motor: ION 250 W 40 Nm
 GHOST Low Rizer light 680 mm 31.8 mm	 Shimano BB BSA	 Shimano XT	 battery: Lithium Ion 360 Wh
 GHOST SL SP 717 31.6 mm	 Shimano XT 44-32-22	 SunRace 11-32	
 GHOST VL 1376	 Shimano XT Disc 180/160 mm		

E-HYBRIDE TRAIL 4000

GREY / BLACK / LIME GREEN











 E-Hybride Trail	 Shimano XT 9-Speed	 Schwalbe Racing Ralph 2.10	 120 mm
 GHOST light AS-007N 31.8 mm	 Shimano SLX	 Schwalbe Racing Ralph 2.10	 44/48/52 cm
 RST First 32 Air SRL 120 mm	 Shimano Acera SL	 Ryde Andra 210	 kg 22.70 kg
 Ritchey Tapered	 Shimano 445	 Alpina F1-3 / DT Swiss 1.8	 motor: ION 250 W 40 Nm
 GHOST Low Rizer light 680 mm 31.8 mm	 Shimano BB BSA	 Shimano Deore	 battery: Lithium Ion 360 Wh
 GHOST SL SP 717 31.6 mm	 Shimano 542 2-pieces	 SunRace 11-32	
 GHOST VL 1490	 Shimano 445 Disc 180/160 mm		

E-HYBRIDE TRAIL 4000 LADY

GREY / BLACK / TURQUOISE



 E-Hybride Trail Lady	 Shimano XT 9-Speed	 Schwalbe Racing Ralph 2.10	 120 mm
 GHOST light A5-007N 31.8 mm	 Shimano SLX	 Schwalbe Racing Ralph 2.10	 44/48/52 cm
 RST First 32 Air SRL 120 mm	 Shimano Acera SL	 Ryde Andra 210	 22.70 kg
 Ritchey Tapered	 Shimano 445	 Alpina F1-3 / DT Swiss 1.8	motor: ION 250 W 40 Nm
 GHOST Low Rizer light 680 mm 31.8 mm	 Shimano BB B5A	 Shimano Deore	battery: Lithium Ion 360 Wh
 GHOST SL SP 717 31.6 mm	 Shimano 542 2-pieces	 SunRace 11-32	
 GHOST VL 1376	 Shimano 445 Disc 180/160 mm		

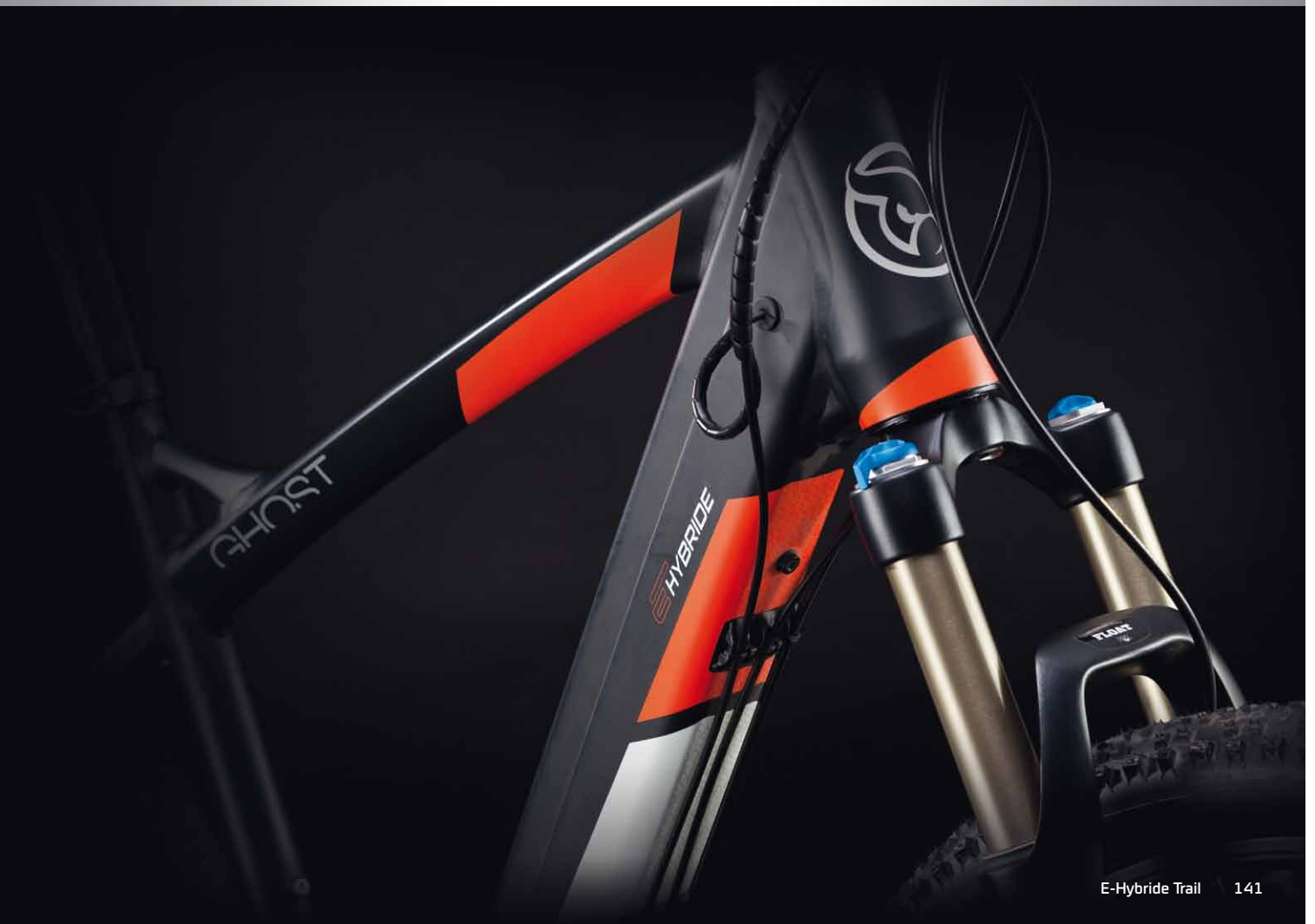

E-HYBRIDE CROSS 9000

GREY / BLACK / BLUE



Mit diesem Bike ist der Weg das Ziel. Unseren Cross-Alurahmen haben wir optimal auf die Anforderungen des Bosch Mittelmotors abgestimmt. Die Shimano XT Ausstattung sorgt für beste Performance. Ob Tour oder City, Feldweg oder Straße - dieses Bike macht Radfahren zu einem ganz besonderen Erlebnis.

The journey is the destination with this bike. We designed our Cross aluminum frames perfectly to fit the requirements of the Bosch middle motor. The Shimano XT equipment delivers maximum performance. Whether it's tours, city riding, dirt or paved roads, cycling is a special experience with this bike.

HYDROFORMING
TUBESET

CONTINUOUS
CABLE HOUSING

BOSCH



























	E-Hybride Cross		Shimano XT Disc 180 mm
	GHOST light AS-007N 31.8 mm		Schwalbe Smart Sam 1.75
	RST Vogue AIR TNL LO 60 mm		Schwalbe Smart Sam 1.75
	Ritchey		Ryde Taurus 19
	GHOST Low Rizer light 680 mm 31.8 mm		DT Swiss 1.8
	GHOST light SP DC 1 27.2 mm		Shimano XT
	Selle Royal Freccia RVL Man		Shimano XT 10-Speed 11-36
	Shimano XT 10-Speed		60 mm
	Shimano XT SL		60 mm
	Shimano XT		M/L/XL
	Bosch		kg
	FSA Metropolis CK 602 38		19.80 kg
			motor: BOSCH 250 W 50 Nm
			battery: Lithium Ion 400 Wh

E-HYBRIDE CROSS 9000 LADY

GREY / BLACK / BLUE



























 E-Hybride Cross Lady	 Shimano XT 10-Speed	 Schwalbe Smart Sam 1.75	 60 mm
 GHOST light AS-007N 31.8 mm	 Shimano XT SL	 Schwalbe Smart Sam 1.75	 5/M/L
 RST Vogue AIR TNL LO 60 mm	 Shimano XT	 Ryde Taurus 19	 kg 19.80 kg
 Ritchey	 Bosch	 DT Swiss 1.8	 motor: BOSCH 250 W 50 Nm
 GHOST Low Rizer light 680 mm 31.8 mm	 FSA Metropolis CK 602 38	 Shimano XT	 battery: Lithium Ion 400 Wh
 GHOST light SP DC 1 27.2 mm	 Shimano XT Disc 180 mm	 Shimano XT 10-Speed 11-36	
 Selle Royal Freccia RVL Lady			

E-HYBRIDE CROSS 4000

GREY / BLACK / GREEN



 E-Hybride Cross	 Shimano XT 10-Speed	 Schwalbe Smart Sam 1.75	 60 mm
 GHOST light AS-007N 31.8 mm	 Shimano Deore SL	 Schwalbe Smart Sam 1.75	 M/L/XL
 RST Neon PLS TNL LO 60 mm	 Tektro HDC 300	 Ryde Taurus 19	 kg 20.30 kg
 Ritchey	 Bosch	 DT Swiss 1.8	 motor: BOSCH 250 W 50 Nm
 GHOST Low Rizer light 680 mm 31.8 mm	 FSA Metropolis CK 602 38	 Shimano 475	 battery: Lithium Ion 300 Wh
 GHOST light SP DC 1 27.2 mm	 Tektro HDC 300 Disc 180/160 mm	 SRAM PG 1070 11-36	
 Selle Royal Freccia RVL Man			

E-HYBRIDE CROSS 4000 LADY

GREY / BLACK / GREEN



- | | | | |
|--|--|---|---|
|  E-Hybride Cross Lady |  Shimano XT 10-Speed |  Schwalbe Smart Sam 1.75 |  60 mm |
|  GHOST light AS-007N 31.8 mm |  Shimano Deore SL |  Schwalbe Smart Sam 1.75 |  S/M/L |
|  RST Neon PLS TNL LO 60 mm |  Tektro HDC 300 |  Ryde Taurus 19 |  kg 20.30 kg |
|  Ritchey |  Bosch |  DT Swiss 1.8 | motor: BOSCH 250 W 50 Nm |
|  GHOST Low Rizer light 680 mm 31.8 mm |  FSA Metropolis CK 602 38 |  Shimano 475 | battery: Lithium Ion 300 Wh |
|  GHOST light SP DC 1 27.2 mm |  Tektro HDC 300 Disc 180/160 mm |  SRAM PG 1070 11-36 | |
|  Selle Royal Freccia RVL Lady | |  | |



E-HYBRIDE TREKKING 9000

GREY / BLACK / BLUE



Unser E-Hybride Trekking 9000 verbindet Eleganz und Sportlichkeit. Der Bosch Mittelmotor garantiert ein zügiges Dahingleiten ohne Anstrengung. Die Shimano XT Gruppe garantiert ein Höchstmaß an Zuverlässigkeit und Funktion. Dazu eigens entwickelte Anbauteile, die jeden Tag auf dem Bike zu einem ganz besonderen Erlebnis werden lassen! Unser E-Hybride Trekking 9000 ist ein Pedelec der neuesten Generation!

Our E-Hybride Trekking 9000 unites elegance with athleticism. The Bosch middle motor guarantees speedy, effortless gliding. The Shimano XT groupset guarantees maximum reliability and functionality. Specially developed components make every day on this bike a unique experience! Our E-Hybride Trekking 9000 is a Pedelec of the latest generation!

HYDROFORMING
TUBESET

CONTINUOUS
CABLE HOUSING

BOSCH





























	E-Hybride Trekking		Shimano XT Disc 180 mm
	GHOST light AS-007N 31.8 mm		Schwalbe Energizer Pro 1.75
	GHOST Light Alloy		Schwalbe Energizer Pro 1.75
	Ritchey Tapered		Ryde Taurus 19
	GHOST Low Rizer light 680 mm 31.8 mm		DT Swiss 1.8
	GHOST light SP DC 1 27.2 mm		Shimano XT Hub Dynamo
	Selle Royal Freccia RVL Man		Shimano XT 10-Speed 11-36
	Shimano XT 10-Speed		
	Shimano XT SL		M/L/XL
	Shimano XT	kg	20.60 kg
	Bosch		motor: BOSCH 250 W 50 Nm
	FSA Metropolis CK 602 38		battery: Lithium Ion 400 Wh

Sonderausstattung E-Hybride TR Series; LED Scheinwerfer, LED Rücklicht mit Standfunktion, Klingel, SKS Pumpe, Curana Schutzbleche, Ständer, Kettenkasten
Special Equipment: LED floodlight, LED backlight, bell, SKS airpump, Curana mudguard, kickstand, chaincase

E-HYBRIDE TREKKING 9000 LADY

WHITE / BROWN / BLUE





























 E-Hybride Trekking Lady	 Shimano XT 10-Speed	 Schwalbe Energizer Pro 1.75	 60 mm
 GHOST light AS-007N 31.8 mm	 Shimano XT SL	 Schwalbe Energizer Pro 1.75	 S/M/L
 GHOST Light Alloy	 Shimano XT 5L	 Ryde Taurus 19	 kg 20.60 kg
 Ritchey Tapered	 Shimano XT	 DT Swiss 1.8	 motor: BOSCH 250 W 50 Nm
 GHOST Low Rizer light 680 mm 31.8 mm	 Bosch	 Shimano XT Hub Dynamo	 battery: Lithium Ion 400 Wh
 GHOST light SP DC 1 27.2 mm	 FSA Metropolis CK 602 38	 Shimano XT 10-Speed 11-36	
 Selle Royal Freccia RVL Lady	 Shimano XT Disc 180 mm		

E-HYBRIDE WAVE 9000

GREY / BLACK / BLUE























 E-Hybride Wave	 Shimano XT 10-Speed	 Schwalbe Energizer Pro 1.75	 60 mm
 Ghost light AS-822 adjustable 25.4 mm	 Shimano XT SL	 Schwalbe Energizer Pro 1.75	 S/M/L/XL
 RST Vogue AIR TNL LO 60 mm	 Shimano XT	 Ryde Taurus 19	 kg 20.80 kg
 Ritchey Tapered	 Bosch	 DT Swiss 1.8	 motor: BOSCH 250 W 50 Nm
 GHOST 620 mm	 FSA Metropolis CK 602 38	 Shimano XT Hub Dynamo	 battery: Lithium Ion 400 Wh
 GHOST light SP DC 1 27.2 mm	 Shimano XT Disc 180 mm	 Shimano XT 10-Speed 11-36	
 Selle Royal Freccia RVL Lady			

E-HYBRIDE TREKKING 4000

GREY / BLACK / GREEN























- | | | | |
|--|--|---|---|
|  E-Hybride Trekking |  Shimano XT 10-Speed |  Schwalbe Energizer Pro 1.75 |  M/L/XL |
|  GHOST light A5-007N 31.8 mm |  Shimano Deore SL |  Schwalbe Energizer Pro 1.75 |  kg 21.00 kg |
|  GHOST Light Alloy |  Tektro HDC 300 |  Ryde Taurus 19 | motor: BOSCH 250 W 50 Nm |
|  Ritchey |  Bosch |  DT Swiss 1.8 | battery: Lithium Ion 300 Wh |
|  GHOST Low Rizer light 680 mm 31.8 mm |  FSA Metropolis CK 602 38 |  Shimano 3D30 Hub Dynamo | |
|  GHOST light SP DC 1 27.2 mm |  Tektro HDC 300 Disc 180/160 mm |  SRAM PG 1070 11-36 | |
|  Selle Royal Freccia RVL Man | | | |

E-HYBRIDE TREKKING 4000

LADY WHITE / SILVER / GREEN

























- | | | | |
|--|--|---|---|
|  E-Hybride Trekking Lady |  Shimano XT 10-Speed |  Schwalbe Energizer Pro 1.75 |  S/M/L |
|  GHOST light A5-007N 31.8 mm |  Shimano Deore SL |  Schwalbe Energizer Pro 1.75 |  kg 21.00 kg |
|  GHOST Light Alloy |  Tektro HDC 300 |  Ryde Taurus 19 | motor: BOSCH 250 W 50 Nm |
|  Ritchey |  Bosch |  DT Swiss 1.8 | battery: Lithium Ion 300 Wh |
|  GHOST Low Rizer light 680 mm 31.8 mm |  FSA Metropolis CK 602 38 |  Shimano 3D30 Hub Dynamo | |
|  GHOST light SP DC 1 27.2 mm |  Tektro HDC 300 Disc 180/160 mm |  SRAM PG 1070 11-36 | |
|  Selle Royal Freccia RVL Lady | | | |

E-HYBRIDE WAVE 4000

GREY / BLACK / GREEN



- | | | | |
|---|--|---|--|
|  E-Hybride Wave |  Shimano XT 10-Speed |  Schwalbe Energizer Pro 1.75 |  60 mm |
|  Ghost light AS-822 adjustable 25.4 mm |  Shimano Deore SL |  Schwalbe Energizer Pro 1.75 |  S/M/L/XL |
|  RST Neon MLO 60 mm |  Tektro HDC 300 |  Ryde Taurus 19 |  21.20 kg |
|  Ritchey |  Bosch |  DT Swiss 1.8 | motor: BOSCH 250 W 50 Nm |
|  GHOST 620 mm |  FSA Metropolis CK 602 38 |  Shimano 3D30 Hub Dynamo | battery: Lithium Ion 300 Wh |
|  GHOST light SP DC 1 27.2 mm |  Tektro HDC 300 Disc 180/160 mm |  SRAM PG 1070 11-36 | |
|  Selle Royal Freccia RVL Lady | | | |





TOWN & COUNTRY

Cross

Tour

■ ■ ■ ■ ■ ■ ■ ■ ■ ■

Trekking

City

■ ■ ■ ■ ■ ■ ■ ■ ■ ■

Tour

■ ■ ■ ■ ■ ■ ■ ■ ■ ■



CROSS





Fahre zu den schönsten Zielen inmitten der Natur. Genieße die Zeit auf deinem Rad. Egal ob eine schnelle Runde auf dem Asphalt oder eine Feierabendtour durch den Wald.

Ride to the most beautiful destinations in nature. Enjoy the time on your bicycle, on a quick road trip or an after-work ride through the woods.

CROSS 9000

BLACK / GREY / RED



Das Topmodell unserer Cross-Linie ist ein Bike der Superlative! Superleichter Alurahmen, optimal einstellbare Luftfedergabel, komplette Shimano XT-Gruppe mit 30 Gängen, leichte Anbauteile. Wir haben an alles gedacht. Mit diesem Bike wird jede Fahrt zum perfekten Erlebnis. Auch als Damenversion erhältlich.

The top-of-the-line model in our Cross series is a bike of superlatives! Super lightweight aluminum frame, optimally adjustable air suspension fork, complete Shimano XT 30-speed groupset derailleurs, lightweight components. We thought of everything. With this bike, every ride becomes a perfect experience. Also available in a Ladies version.

PM DIRECT

HYDROFORMING
TUBESET

CONTINUOUS
CABLE HOUSING



	Cross 7005 DB		Shimano XT Disc 180 mm
	GHOST light AS-007N 31.8 mm		Schwalbe Smart Sam Sport
	RST Vogue AIR TNL LO 60 mm		Schwalbe Smart Sam Sport
	Ritchey		Ryde Taurus
	GHOST Low Rizer light 660 mm 31.8 mm		DT Swiss 1.8
	GHOST SL SP 717 27.2 mm		Shimano XT
	GHOST VL 3135		Shimano CS-HG81 11-34
	Shimano XT 10-Speed		60 mm
	Shimano XT		60 mm
	Shimano XT SL		45/49/53/57/61 cm
	Shimano XT		11.70 kg
	Shimano BB51 BSA		
	Shimano XT 48-36-26		

CROSS 9000 LADY

BLACK / GREY / RED



- | | | | |
|--------------------------------------|------------------------|--------------------------|----------------|
| Cross 7005 DB | Shimano XT 10-Speed | Schwalbe Smart Sam Sport | 60 mm |
| GHOSH light AS-007N 31.8 mm | Shimano XT | Schwalbe Smart Sam Sport | 40/44/48/52 cm |
| RST Vogue AIR TNL LO 60 mm | Shimano XT SL | Ryde Taurus | kg 11.70 kg |
| Ritchey | Shimano XT | DT Swiss 1.8 | |
| GHOSH Low Rizer light 660 mm 31.8 mm | Shimano BB51 BSA | Shimano XT | |
| GHOSH SL SP 717 27.2 mm | Shimano XT 48-36-26 | Shimano CS-HG81 11-34 | |
| GHOSH VL 4212 | Shimano XT Disc 180 mm | | |

CROSS 7500

BLACK / WHITE / GREY



- | | | | |
|--------------------------------------|-------------------------|--------------------------|-------------------|
| Cross 7005 DB | Shimano XT 10-Speed | Schwalbe Smart Sam Sport | 60 mm |
| GHOSH light AS-007N 31.8 mm | Shimano XT | Schwalbe Smart Sam Sport | 45/49/53/57/61 cm |
| RST Vogue AIR TNL LO 60 mm | Shimano Deore SL | Ryde Taurus | kg 11.90 kg |
| Ritchey | Shimano 445 | DT Swiss 1.8 | |
| GHOSH Low Rizer light 660 mm 31.8 mm | Shimano BB51 BSA | Shimano Deore | |
| GHOSH light SP DC 1 27.2 mm | Shimano XT 48-36-26 | SRAM PG-1030 11-36 | |
| GHOSH VL 3135 | Shimano 445 Disc 180 mm | | |

CROSS 7500 LADY

BLACK / WHITE / GREY



Cross 7005 DB	Shimano XT 10-Speed	Schwalbe Smart Sam Sport	60 mm
GHOST light AS-007N 31.8 mm	Shimano XT	Schwalbe Smart Sam Sport	40/44/48/52 cm
RST Vogue AIR TNL LO 60 mm	Shimano Deore SL	Ryde Taurus	kg 11.90 kg
Ritchey	Shimano 445	DT Swiss 1.8	
GHOST Low Rizer light 660 mm 31.8 mm	Shimano BB51 BSA	Shimano Deore	
GHOST light SP DC 1 27.2 mm	Shimano XT 48-36-26	SRAM PG-1030 11-36	
GHOST VL 4212	Shimano 445 Disc 180 mm		

CROSS 5500

LIGHT GREY / WHITE / BLUE

























Cross 7005 DB	Shimano XT 9-Speed	Schwalbe Smart Sam Sport	60 mm
GHOST light AS-007N 31.8 mm	Shimano Deore	Schwalbe Smart Sam Sport	45/49/53/57/61 cm
RST Neon PLS TNL 60 mm	Shimano Deore SL	Ryde Taurus	kg 12.70 kg
Ritchey	Shimano 445	DT Swiss 1.8	
GHOST Low Rizer light 660 mm 31.8 mm	Shimano BB BSA	Shimano Deore	
GHOST light SP DC 1 27.2 mm	Shimano FCM 543 48-36-26	Shimano 11-32	
GHOST VL 3135	Shimano 445 Disc 180 mm		

CROSS 5500 LADY

GREY / BLACK / PETROL

























 Cross 7005 DB	 Shimano XT 9-Speed	 Schwalbe Smart Sam Sport	 60 mm
 GHOSH light AS-007N 31.8 mm	 Shimano Deore	 Schwalbe Smart Sam Sport	 40/44/48/52 cm
 RST Neon PSL TNL LO 60 mm	 Shimano Deore SL	 Ryde Taurus	kg 12.70 kg
 Ritchey	 Shimano 445	 DT Swiss 1.8	
 GHOSH Low Rizer light 660 mm 31.8 mm	 Shimano BB BSA	 Shimano Deore	
 GHOSH light SP DC 1 27.2 mm	 Shimano FCM 543 48-36-26	 Shimano 11-32	
 GHOSH VL 4212	 Shimano 445 Disc 180 mm		

CROSS 5100

SILVER / WHITE / GREY















 Cross 7005 DB	 Shimano XT 9-Speed	 Schwalbe Smart Sam Sport	 60 mm
 GHOSH light AS-007N 31.8 mm	 Shimano Alivio	 Schwalbe Smart Sam Sport	 45/49/53/57/61 cm
 RST Neon PLS 60 mm	 Shimano Acera SL	 Ryde Taurus	kg 13.10 kg
 Ritchey	 Tektro HDC 300	 DT Swiss 1.8	
 GHOSH Low Rizer light 660 mm 31.8 mm	 Shimano BBES-25	 SRAM 306	
 GHOSH light SP DC 1 27.2 mm	 Shimano FCM 431 48-36-26	 Shimano 11-32	
 GHOSH VL 3135	 Tektro HDC 300 Disc 160 mm		

CROSS 5100 LADY

SILVER / WHITE / GREY

























 Cross 7005 DB	 Shimano XT 9-Speed	 Schwalbe Smart Sam Sport	 60 mm
 GHOST light AS-007N 31.8 mm	 Shimano Alivio	 Schwalbe Smart Sam Sport	 40/44/48/52 cm
 RST Neon PLS 60 mm	 Shimano Acera SL	 Ryde Taurus	 kg 13.10 kg
 Ritchey	 Tektro HDC 300	 DT Swiss 1.8	
 GHOST Low Rizer light 660 mm 31.8 mm	 Shimano BBES-25	 SRAM 306	
 GHOST light SP DC 1 27.2 mm	 Shimano FCM 431 48-36-26	 Shimano 11-32	
 GHOST VL 4212	 Tektro HDC 300 Disc 160 mm		

CROSS 1800

BLACK / WHITE / LIME GREEN



 Cross 7005 PG	 Shimano Deore 9-Speed	 Schwalbe Smart Sam Sport	 60 mm
 GHOST light AS-007N 31.8 mm	 Shimano Acera	 Schwalbe Smart Sam Sport	 45/49/53/57/61 cm
 RST Neon PLS MLD 60 mm	 Shimano Acera SL	 Ryde Taurus	 kg 13.50 kg
 Ritchey	 Tektro HDC 300	 DT Swiss 1.8	
 GHOST Low Rizer light 660 mm 31.8 mm	 Shimano BBES-25	 SRAM 306	
 GHOST light SP DC 1 31.6 mm	 Shimano 391 48-36-26	 Shimano 11-32	
 GHOST VL 3135	 Tektro HDC 300 Disc 160 mm		

CROSS 1800 LADY

WHITE / BLUE / GREEN



- | | | | |
|--------------------------------------|----------------------------|--------------------------|----------------|
| Cross 7005 PG | Shimano Deore 9-Speed | Schwalbe Smart Sam Sport | 60 mm |
| GHOST light AS-007N 31.8 mm | Shimano Acera | Schwalbe Smart Sam Sport | 40/44/48/52 cm |
| RST Neon PLS MLO 60 mm | Shimano Acera SL | Ryde Taurus | kg 13.50 kg |
| Ritchey | Tektro HDC 300 | DT Swiss 1.8 | |
| GHOST Low Rizer light 660 mm 31.8 mm | Shimano BBES-25 | SRAM 306 | |
| GHOST light SP DC 1 31.6 mm | Shimano 391 48-36-26 | Shimano 11-32 | |
| GHOST VL 4212 | Tektro HDC 300 Disc 160 mm | | |

CROSS 1300

BLACK / GREY / GREEN

























- | | | | |
|--------------------------------------|--------------------------|--------------------------|-------------------|
| Cross 7005 PG | Shimano Acera 8-Speed | Schwalbe Smart Sam Sport | 60 mm |
| GHOST light AS-007N 31.8 mm | Shimano | Schwalbe Smart Sam Sport | 45/49/53/57/61 cm |
| RST Neon MLO 60 mm | Shimano Altus STI | Ryde Zac Pro | kg 12.90 kg |
| Ritchey | Shimano Altus STI | DT Swiss 1.8 | |
| GHOST Low Rizer light 660 mm 31.8 mm | Shimano BBUN-26 | Shimano | |
| GHOST light SP DC 1 31.6 mm | Shimano FCM 171 48-38-28 | SRAM PG-820 11-30 | |
| GHOST VL 3135 | Shimano V-Brake | | |

CROSS 1300 LADY

WHITE / GREY / GREEN



- | | | | |
|--|--|--|--|
|  Cross 7005 PG |  Shimano Acera 8-Speed |  Schwalbe Smart Sam Sport |  60 mm |
|  GHOST light A5-007N 31.8 mm |  Shimano |  Schwalbe Smart Sam Sport |  40/44/48/52 cm |
|  RST Neon MLO 60 mm |  Shimano Altus STI |  Ryde Zac Pro |  kg 12.90 kg |
|  Ritchey |  Shimano Altus STI |  DT Swiss 1.8 | |
|  GHOST Low Rizer light 660 mm 31.8 mm |  Shimano BBUN-26 |  Shimano | |
|  GHOST light SP DC 1 31.6 mm |  Shimano FCM 171 48-38-28 |  SRAM PG-820 11-30 | |
|  GHOST VL 4212 Lady |  Shimano V-Brake | | |

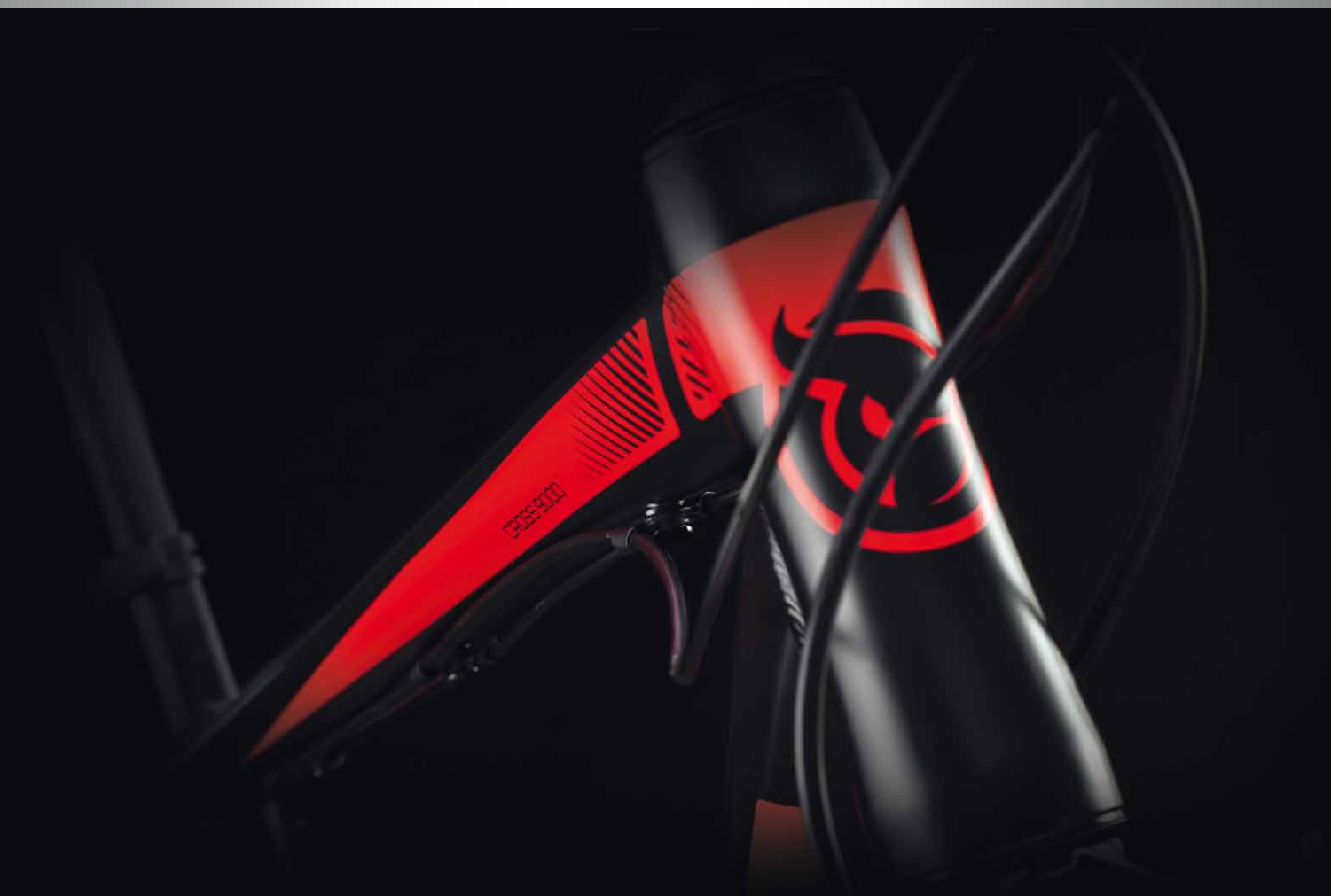

TREKKING





Unsere Allrounder. Ihre hochwertige Ausstattung garantiert jahrelangen Einsatz in Alltag und Freizeit. Dank Vollausstattung mit Licht und Schutzblechen sind sie uneingeschränkt alltagstauglich. Egal, ob du auf weite Reise mit deinem Rad gehst oder einfach nur sicher und entspannt zur Arbeit kommen willst. Unsere GHOST Trekking-Linie: wahre Allrounder und für alle Fälle bestens gerüstet!

Our Allrounders. Their high-quality equipment guarantees years of use for every-day and leisure rides. Thanks to being fully equipped with light systems and mudguards, they are suitable for every-day use without limitations. It doesn't matter whether you take your bicycle on a long journey or whether you just want to relax and get to work safely. Our GHOST Trekking bikes are real allrounders and are well equipped for any situation!

TREKKING 7600 ALFINE

BLACK / GREY / GREY



Bei diesem Modell haben wir unseren innovativen Trekking-Alurahmen mit einer Shimano Alfine 11-Gang-Nabenschaltung, Scheibenbremsen und einer leichten Starrgabel ausgerüstet. Dazu B&M LED-Beleuchtung und Chainglider. Das Ergebnis ist ein Trekking-Rad der absoluten Spitzenklasse. Leicht, zuverlässig, sicher, bequem und wunderschön!

This model features our innovative Trekking aluminum frame with a Shimano Alfine 11-speed gear hub system, disc brakes and a lightweight rigid fork. In addition, a B&M LED light system and chain gliders. The result is a Trekking bike of an ultra-premium class. Lightweight, reliable, safe, comfortable and simply beautiful!

PM DIRECT

HYDROFORMING
TUBESET

CONTINUOUS
CABLE HOUSING



	Trekking 7005 DB		Shimano XT Disc 180 mm
	GHOST light AS-007N 31.8 mm		Schwalbe Big Apple 2.00
	RST RF-M7 Rigid		Schwalbe Big Apple 2.00
	Ritchey		Alex TD 17
	GHOST Low Rizer light 640 mm 31.8 mm		DT Swiss 1.8
	GHOST light SP DC 1 27.2 mm		Shimano Hub Dynamo
	Selle Royal Freccia RVL Man		Shimano Alfine
	Shimano Alfine Internal Geared Hub 11-Speed		Shimano XT
	Shimano Alfine		SRAM BB BSA
	Shimano XT		Truvativ Firex Single 38
	SRAM BB BSA		45/49/53/57/61 cm
	Truvativ Firex Single 38		14.60 kg

Sonderausstattung TR Series: LED Scheinwerfer, LED Rücklicht mit Standfunktion, Klingel, SKS Pumpe und Schutzbleche, Ständer, Kettenkasten
Special Equipment: LED floodlight, LED backlight, bell, SKS airpump and mudguard, kickstand, chaincase

TR 7500

BLACK / GREY / BLUE



Trekking 7005 DB	Shimano XT 10-Speed	Schwalbe Marathon Evo	60mm
GHOST light AS-007N 31.8 mm	Shimano XT	Schwalbe Marathon Evo	45/49/53/57/61 cm
RST Vogue AIR TNL LO 60 mm	Shimano XT SL	Alex TD 17	14.00 kg
Ritchey	Shimano 596	DT Swiss 1.8	
GHOST Low Rizer light 640 mm 31.8 mm	Shimano BB BSA	Shimano XT Hub Dynamo	
GHOST light SP DC 1 27.2 mm	Shimano XT 48-36-26	Shimano CS-HG62 11-34	
Selle Royal Freccia RVL Man	Shimano 596 Disc 180 mm		

TR 5700

BLACK / COPPER / SILVER







Trekking 7005 DB	Shimano XT 9-Speed	Schwalbe Road Cruiser	60 mm
GHOST light AS-007N 31.8 mm	Shimano Deore	Schwalbe Road Cruiser	45/49/53/57/61 cm
RST Vogue AIR TNL LO 60 mm	Shimano Deore SL	Alex TD 17	14.30 kg
Ritchey	Shimano 445	DT Swiss 1.8	
GHOST Low Rizer light 640 mm 31.8 mm	Shimano BB BSA	Shimano Hub Dynamo	
GHOST light SP DC 1 27.2 mm	Shimano FCM 543 48-36-26	SRAM PG-950 11-32	
Selle Royal Freccia RVL Man	Shimano 445 Disc 180 mm		

TR 5700 LADY

BLACK / COPPER / SILVER

























 Trekking 7005 DB	 Shimano XT 9-Speed	 Schwalbe Road Cruiser	 60 mm
 GHOST light A5-007N 31.8 mm	 Shimano Deore	 Schwalbe Road Cruiser	 40/44/48/52 cm
 RST Vogue AIR TNL LO 60 mm	 Shimano Deore SL	 Alex TD 17	 14.30 kg
 Ritchey	 Shimano 445	 DT Swiss 1.8	
 GHOST Low Rizer light 640 mm 31.8 mm	 Shimano BB B5A	 Shimano Hub Dynamo	
 GHOST light SP DC 1 27.2 mm	 Shimano FCM 543 48-36-26	 SRAM PG-950 11-32	
 Selle Royal Freccia RVL Lady	 Shimano 445 Disc 180 mm		

TR 5200 ALFINE

BLACK / GREY / GREY



 Trekking 7005 DB	 Shimano Alfine Internal Geared Hub 8-Speed	 Schwalbe Big Apple 2.00	 60 mm
 GHOST light A5-007N 31.8 mm	 Shimano Alfine	 Schwalbe Big Apple 2.00	 45/49/53/57/61 cm
 RST RF-M7 Rigid	 Shimano 505	 Alex TD 17	 14.90 kg
 Ritchey	 SRAM BB B5A	 DT Swiss 1.8	
 GHOST Low Rizer light 640 mm 31.8 mm	 SRAM BB B5A	 Shimano Alfine Hub Dynamo	
 GHOST light SP DC 1 27.2 mm	 Truvativ Firex Single 38		
 Selle Royal Freccia RVL Man	 Shimano 505 Disc 180/160 mm		

TR 5100

BLACK / GREY / RED



 Trekking 7005 PG	 Shimano XT 9-Speed	 Schwalbe Road Cruiser	 60 mm
 Ghost light AS-822 adjustable 25.4 mm	 Shimano Deore	 Schwalbe Road Cruiser	 45/49/53/57/61 cm
 RST Neon PLS TnL 60 mm	 Shimano Acera SL	 Alex ACE 18	 kg 14.80 kg
 Ritchey	 Avid FR 5	 DT Swiss 1.8	
 GHOST 620 mm	 Shimano Octalink	 Shimano Hub Dynamo	
 GHOST light SP DC 1 27.2 mm	 Shimano 391 48-36-26	 Shimano 11-32	
 Selle Royal Freccia RVL Man	 Avid Single Digit 5		

TR 5100 LADY

WHITE / GREY / AUBERGINE



 Trekking 7005 PG	 Shimano XT 9-Speed	 Schwalbe Road Cruiser	 60 mm
 Ghost light AS-822 adjustable 25.4 mm	 Shimano Deore	 Schwalbe Road Cruiser	 40/44/48/52 cm
 RST Neon PLS TnL 60 mm	 Shimano Acera SL	 Alex ACE 18	 kg 14.80 kg
 Ritchey	 Avid FR 5	 DT Swiss 1.8	
 GHOST 620 mm	 Shimano Octalink	 Shimano Hub Dynamo	
 GHOST light SP DC 1 27.2 mm	 Shimano 391 48-36-26	 Shimano 11-32	
 Selle Royal Freccia RVL Lady	 Avid Single Digit 5		

TR 5100 WAVE

WHITE / GREY / AUBERGINE



Trekking 7005 PG	Shimano XT 9-Speed	Schwalbe Road Cruiser	60 mm
Ghost light AS-822 adjustable 25.4 mm	Shimano Deore	Schwalbe Road Cruiser	40/44/48/52 cm
RST Neon PLS TrL 60 mm	Shimano Acera SL	Alex ACE 18	kg 14.90 kg
Ritchey	Avid FR 5	DT Swiss 1.8	
GHOST 620 mm	Shimano Octalink	Shimano Hub Dynamo	
GHOST light SP DC 1 27.2 mm	Shimano 391 48-36-26	Shimano 11-32	
Selle Royal Freccia RVL Lady	Avid Single Digit 5		

TR 3500 NEXUS

BLACK / GREY / RED



Trekking 7005 PG	Shimano Nexus Internal Geared Hub 8-Speed	Schwalbe Road Cruiser	50 mm
Ghost light AS-822 adjustable 25.4 mm	Shimano Nexus	Schwalbe Road Cruiser	45/49/53/57/61 cm
Suntour SF13-CR-8V MLO 50 mm	Shimano V-Brake	Ryde Zac Pro	kg 16.80 kg
Ritchey	Shimano BBUN-26	DT Swiss 1.8	
GHOST 620 mm	Shimano Nexus 38	Shimano Hub Dynamo	
GHOST light SP DC 1 31.6 mm	Shimano V-Brake		
Selle Royal Freccia RVL Man			

TR 3500 LADY NEXUS

WHITE / GREY / RED



Trekking 7005 PG	Shimano Nexus Internal Geared Hub 8-Speed	Schwalbe Road Cruiser	50 mm
Ghost light AS-822 adjustable 25.4 mm	Shimano Nexus	Schwalbe Road Cruiser	40/44/48/52 cm
Suntour SF13-CR-8V MLO 50 mm	Shimano V-Brake	Ryde Zac Pro	kg 16.80 kg
Ritchey	Shimano BBUN-26	DT Swiss 1.8	
GHOST 620 mm	Shimano Nexus 38	Shimano Hub Dynamo	
GHOST light SP DC 1 31.6 mm	Shimano V-Brake		
Selle Royal Freccia RVL Lady			

TR 3500 WAVE NEXUS

WHITE / GREY / RED

























Trekking 7005 PG	Shimano Nexus Internal Geared Hub 8-Speed	Schwalbe Road Cruiser	50mm
Ghost light AS-822 adjustable 25.4 mm	Shimano Nexus	Schwalbe Road Cruiser	40/44/48/52 cm
Suntour SF13-CR-8V MLO 50 mm	Shimano V-Brake	Ryde Zac Pro	kg 16.90 kg
Ritchey	Shimano BBUN-26	DT Swiss 1.8	
GHOST 620 mm	Shimano Nexus 38	Shimano Hub Dynamo	
GHOST light SP DC 1 31.6 mm	Shimano V-Brake		
Selle Royal Freccia RVL Lady			

TR 1800

GREY / LIME GREEN / BLACK

























- | | | | |
|---|--|---|--|
|  Trekking 7005 PG |  Shimano Alivio 9-Speed |  Schwalbe Road Cruiser |  |
|  Ghost light AS-822 adjustable 25.4 mm |  Shimano Acera |  Schwalbe Road Cruiser |  45/49/53/57/61 cm |
|  RST RF-M7 Rigid |  Shimano Acera SL |  Alex ACE 18 |  kg 14.70 kg |
|  Ritchey |  Shimano Acera SL |  DT Swiss 1.8 | |
|  GHOST 620 mm |  Shimano Octalink |  Shimano Hub Dynamo | |
|  GHOST light SP DC 1 31.6 mm |  Shimano 391 48-36-26 |  Shimano 11-32 | |
|  Selle Royal Freccia RVL Man |  Shimano V-Brake | | |

TR 1800 LADY

WHITE / GREY / LIME GREEN

























- | | | | |
|---|--|---|--|
|  Trekking 7005 PG |  Shimano Alivio 9-Speed |  Schwalbe Road Cruiser |  |
|  Ghost light AS-822 adjustable 25.4 mm |  Shimano Acera |  Schwalbe Road Cruiser |  40/44/48/52 cm |
|  RST RF-M7 Rigid |  Shimano Acera SL |  Alex ACE 18 |  kg 14.70 kg |
|  Ritchey |  Shimano Acera SL |  DT Swiss 1.8 | |
|  GHOST 620 mm |  Shimano Octalink |  Shimano Hub Dynamo | |
|  GHOST light SP DC 1 31.6 mm |  Shimano 391 48-36-26 |  Shimano 11-32 | |
|  Selle Royal Freccia RVL Lady |  Shimano V-Brake | | |

TR 1800 WAVE

WHITE / GREY / LIME GREEN



























 Trekking 7005 PG	 Shimano Alivio 9-Speed	 Schwalbe Road Cruiser	
 Ghost light AS-822 adjustable 25.4 mm	 Shimano Acera	 Schwalbe Road Cruiser	 40/44/48/52 cm
 RST RF-M7 Rigid	 Shimano Acera SL	 Alex ACE 18	 kg 14.80 kg
 Ritchey	 Shimano Acera SL	 DT Swiss 1.8	
 GHOST 620 mm	 Shimano Octalink	 Shimano Hub Dynamo	
 GHOST light SP DC 1 31.6 mm	 Shimano 391 48-36-26	 Shimano 11-32	
 Selle Royal Freccia RVL Lady	 Shimano V-Brake		

TR 1300

BLACK / GREY / COPPER



 Trekking 7005 PG	 Shimano Altus 8-Speed	 Schwalbe Road Cruiser	 60 mm
 Ghost light AS-822 adjustable 25.4 mm	 Shimano Acera	 Schwalbe Road Cruiser	
 RST Neon MLD 60 mm	 Shimano Altus STI	 Alex ACE 18	 45/49/53/57/61 cm
 Ritchey	 Shimano Altus STI	 DT Swiss 1.8	 kg 15.20 kg
 GHOST 620 mm	 Shimano BBUN-26	 Shimano Hub Dynamo	
 GHOST light SP DC 1 31.6 mm	 Shimano FCM 171 48-38-28	 SRAM PG-820 11-30	
 Selle Royal Freccia RVL Man	 Tektro V-Brake		

TR 1300 LADY

BLACK / GREY / COPPER



 Trekking 7005 PG	 Shimano Altus 8-Speed	 Schwalbe Road Cruiser	 60 mm
 Ghost light AS-822 adjustable 25.4 mm	 Shimano Acera	 Schwalbe Road Cruiser	 40/44/48/52 cm
 RST Neon MLO 60 mm	 Shimano Altus STI	 Alex ACE 18	 15.20 kg
 Ritchey	 Shimano Altus STI	 DT Swiss 1.8	
 GHOST 620 mm	 Shimano BBUN-26	 Shimano Hub Dynamo	
 GHOST light SP DC 1 31.6 mm	 Shimano FCM 171 48-38-28	 SRAM PG-820 11-30	
 Selle Royal Freccia RVL Lady	 Tektro V-Brake		

TR 1300 WAVE

BLACK / GREY / COPPER



 Trekking 7005 PG	 Shimano Altus 8-Speed	 Schwalbe Road Cruiser	 60 mm
 Ghost light AS-822 adjustable 25.4 mm	 Shimano Acera	 Schwalbe Road Cruiser	 40/44/48/52 cm
 RST Neon MLO 60 mm	 Shimano Altus STI	 Alex ACE 18	 15.30 kg
 Ritchey	 Shimano Altus STI	 DT Swiss 1.8	
 GHOST 620 mm	 Shimano BBUN-26	 Shimano Hub Dynamo	
 GHOST light SP DC 1 31.6 mm	 Shimano FCM 171 48-38-28	 SRAM PG-820 11-30	
 Selle Royal Freccia RVL Lady	 Tektro V-Brake		

ROAD



Race

Road

Race



Speedline

Road

Urban

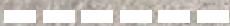



RACE





Die GHOST Race-Räder sind auf den Asphalt-Untergründen dieser Welt zu Hause. Sie sind sicher und stark bergauf sowie verwindungssteif und perfekt kontrollierbar bergab. Das zeitlos pure Design rundet diese formschönen Rennräder vollends ab.

The GHOST Race bicycles are at home on the asphalt of this world. They are safe and powerful on the uphill, as well as stiff and controlled perfectly on the downhill. The timeless and pure design round these beautiful road bikes off perfectly.

RACE LECTOR RED

BLACK / GREY / RED



Perfektion auf zwei Rädern. Unser ultraleichtes Carbonrahmenset, ausgestattet mit Sram RED, Easton-Vollcarbon-Aero-Laufrädern und FSA-Anbauteilen, ist das beste Race, das wir jemals gebaut haben! Genieße die Faszination perfekter Technik und traumhaft schöner Optik. Erlebe Perfektion.

Perfection on two wheels. Our ultra-light carbon frame set with Sram RED, Easton full-carbon Aero wheelset and FSA components is the absolute best Race bike we have ever built! Experience and enjoy the fascination of perfect technology and absolutely beautiful design. Experience true perfection.

MIMS

THT | TAPERED HEAD TUBE





























-  Race HM Carbon MIMS AFT SCL
-  FSA OS-99 CSI 31.8 mm
-  CG Carbon
-  Tapered
-  FSA Road SL-K Compact 31.8 mm
-  FSA SP 31.6 mm
-  Prologo Zero2
-  SRAM Red 10-Speed
-  SRAM Red
-  SRAM Red Double Tap
-  SRAM Red Double Tap
-  SRAM BB BSA
-  SRAM Red Compact 50-34

-  SRAM Red
-  Schwalbe Ultremo
-  Schwalbe Ultremo
-  Easton EC 90 SL Wheelset
-  Easton EC 90 SL Wheelset
-  Easton EC 90 SL Wheelset
-  SRAM Red 1090 11-25
-  SRAM Red 1090 11-25
-  SRAM Red 1090 11-25
-  SRAM Red 1090 11-25
-  SRAM Red 1090 11-25
-  kg 6.60 kg

RACE LECTOR PRO

BLACK / WHITE / GREY





























- | | | | |
|---|---|---|---|
|  Race HM Carbon ACR SCL |  Shimano Ultegra Di2 10-Speed |  Schwalbe Ultremo |  |
|  FSA ST-05-190/CW-UD 31.8 mm |  Shimano Ultegra Di2 |  Schwalbe Ultremo |  |
|  CG Carbon |  Shimano Ultegra Di2 |  Easton Aero Wheelset |  |
|  Tapered |  Shimano Ultegra Di2 |  Easton Aero Wheelset |  |
|  FSA Road Wing Pro Compact 31.8 mm |  Shimano Pressfit BB |  Easton Aero Wheelset |  |
|  FSA Team Issue 27,2 mm |  Shimano Ultegra Compact 50-34 |  Shimano Ultegra 11-28 |  |
|  Prologo Zero2 |  Shimano Ultegra | |  |
- 47/50/53/56/59 cm
kg 7.60 kg

RACE LECTOR 7000

BLACK / GREY / BLUE









- | | | | |
|---|---|--|---|
|  Race HM Carbon ACR SCL |  Shimano 105 10-Speed |  Schwalbe Durano |  |
|  FSA 190 Laser 31.8 mm |  Shimano 105 |  Schwalbe Durano |  |
|  CG Carbon |  Shimano 105 |  Easton 700C Wheelset |  |
|  Tapered |  Shimano 105 |  Easton 700C Wheelset |  |
|  FSA Road Vero Compact 31.8 mm |  Shimano Pressfit BB |  Easton 700C Wheelset |  |
|  GH0ST SL SP 717 27.2 mm |  Shimano 105 Compact 50-34 |  Shimano 105 11-28 |  |
|  Prologo Zero2 |  Shimano 105 | |  |
- 47/50/53/56/59 cm
kg 7.90 kg

RACE 6000



BLACK / WHITE / GREY



-  Race Actinum DB AFT
-  FSA 190 Laser 31.8 mm
-  CG Carbon
-  Ritchey
-  FSA Road Vero Compact 31.8 mm
-  GHOST light SP DC 1 27.2 mm
-  Prologo

-  Shimano Ultegra 10-Speed
-  Shimano Ultegra
-  Shimano Ultegra
-  Shimano Ultegra
-  Shimano BB B5A
-  Shimano Ultegra Compact 50-34
-  Shimano Ultegra

-  Schwalbe Ultremo
-  Schwalbe Ultremo
-  Easton 700C Wheelset
-  Easton 700C Wheelset
-  Easton 700C Wheelset
-  Shimano Ultegra 11-28

-  47/50/53/56/58/60/62 cm
-  kg 8.10 kg

RACE 5000



BLACK / GREY / BLUE



-  Race Actinum DB AFT
-  FSA 190 Laser 31.8 mm
-  CG Carbon
-  Ritchey
-  FSA Road Vero Compact 31.8 mm
-  GHOST light SP DC 1 27.2 mm
-  Prologo

-  Shimano 105 10-Speed
-  Shimano 105
-  Shimano 105
-  Shimano 105
-  Shimano BB B5A
-  Shimano 105 Compact 50-34
-  Shimano 105

























-  Schwalbe Durano
-  Schwalbe Durano
-  Shimano Wheelset
-  Shimano Wheelset
-  Shimano Wheelset
-  Shimano 105 11-28

-  47/50/53/56/58/60/62 cm
-  kg 8.40 kg

RACE 4900

BLACK / WHITE / RED



- | | | | |
|---|---|--|---|
|  Race Actinum DB AFT |  Shimano Tiagra 10-Speed |  Schwalbe Durano |  |
|  FSA 190 Laser 31.8 mm |  Shimano Tiagra |  Schwalbe Durano |  |
|  CG Carbon |  Shimano Tiagra |  Shimano Wheelset |  |
|  Ritchey Tapered |  Shimano Tiagra |  Shimano Wheelset |  |
|  FSA Road Vero Compact 31.8 mm |  Shimano BB51 BSA |  Shimano Wheelset |  |
|  GHOST light SP DC 1 27.2 mm |  Shimano Tiagra 50-39-30 |  Shimano Wheelset |  |
|  Prologo |  Shimano Tiagra |  Shimano Tiagra 12-30 |  |
- 47/50/53/56/58/60/62 cm
kg 8.60 kg





SPEEDLINE

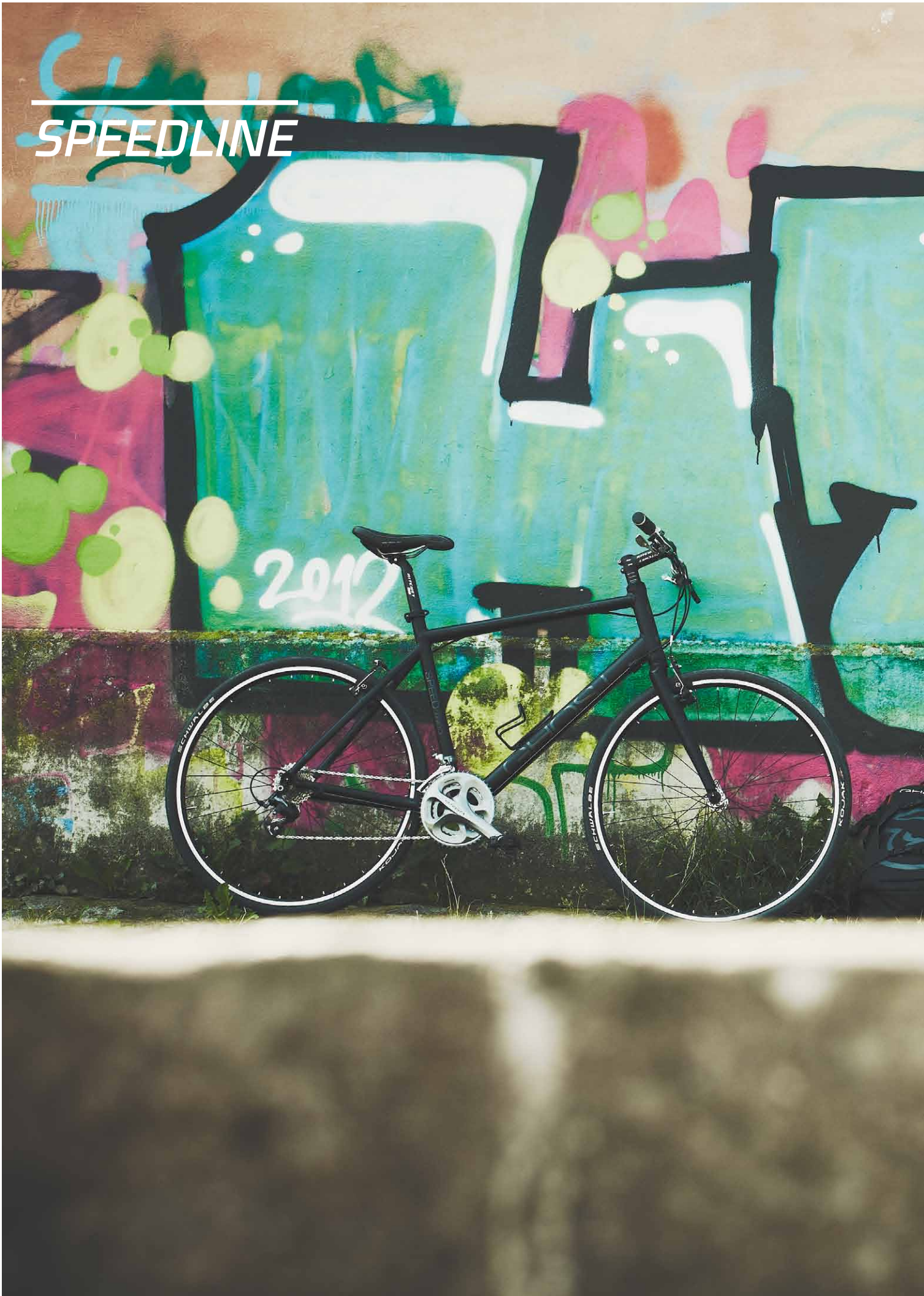



Die GHOST Speedline-Modelle sind absolute Allrounder und sowohl für die Stadt als auch für die Tour am Wochenende bestens geeignet. Sie vereinen Komfort mit Sportlichkeit und elegantem Design.

The GHOST Speedline models are absolute allrounders, and are suitable for both the city and for a weekend tour. They combine comfort with sportiness and elegant design.

SPEEDLINE LECTOR 9000

BLACK / GREY / GREY







Das Speedline Topmodell haben wir mit unserem superleichten Carbonrahmen, Carbon-Gabel und Shimano Ultegra-Schaltung ausgestattet. Dazu Shimano XT-Scheibenbremsen. Perfekte Funktion, überragendes Gewicht und traumhaft schöne Optik. Ein Speedline in Perfektion.

The Speedline top-of-the-line model features our super lightweight carbon frame, carbon fork, Shimano Ultegra set and Shimano XT disc brakes. Perfect functionality, outstanding weight and absolutely beautiful design. A Speedline in true perfection.

MIMS

CONTINUOUS
CABLE HOUSING







	Speedline Carbon SCL		Shimano XT Disc 180 mm
	GHOST light AS-029 31.8 mm		Schwalbe Kojak
	GHOST XDS Carbon		Schwalbe Kojak
	Integrated		Alex TD 17
	GHOST Low Rizer light 640 mm 31.8 mm		DT Swiss 1.8
	GHOST SL SP 717 31.6 mm		Shimano XT
	Selle Royal XSENIUM Lookin		Shimano Ultegra 11-28
	Shimano Ultegra 10-Speed		
	Shimano Ultegra		
	Shimano SL 780 Flat		48/54/58 cm
	Shimano XT		9.70 kg
	Shimano BB BSA		
	Shimano Ultegra Compact 50-34		

SPEEDLINE 7500

BLACK / GREY / RED



- | | | | |
|--|---|---|---|
|  Speedline 7005 DB SCL |  Shimano Ultegra 10-Speed |  Schwalbe Kojak |  |
|  GHOST light AS-029 31.8 mm |  Shimano Ultegra |  Schwalbe Kojak |  |
|  RST RF-M7 Rigid |  Shimano SL 780 Flat |  Alex TD 17 |  |
|  Ritchey |  Shimano 596 |  DT Swiss 1.8 |  |
|  GHOST Low Rizer light 640 mm 31.8 mm |  Shimano BB BSA |  Shimano XT |  |
|  GHOST SL SP 717 31.6 mm |  Shimano 105 Compact 50-34 |  Shimano 105 11-28 |  |
|  Selle Royal XSENIUM Lookin |  Shimano 596 Disc 180 mm | |  |

SPEEDLINE 5700

SILVER / GREY / WHITE



- | | | | |
|--|---|---|---|
|  Speedline 7005 DB SCL |  Shimano Ultegra 10-Speed |  Schwalbe Kojak |  |
|  GHOST light AS-007N 31.8 mm |  Shimano 105 |  Schwalbe Kojak |  |
|  RST RF-M7 Rigid |  Shimano SL 780 Flat |  Alex TD 17 |  |
|  Ritchey |  Shimano 445 |  DT Swiss 1.8 |  |
|  GHOST Low Rizer light 640 mm 31.8 mm |  FSA BB BSA |  Shimano Deore |  |
|  GHOST light SP DC 1 31.6 mm |  FSA Gossamer Mega Exo Compact 50-34 |  Shimano 105 11-28 |  |
|  Selle Royal XSENIUM Lookin |  Shimano 445 Disc 180 mm | |  |



POWERKID



Powerkid

Be happy

Adventure



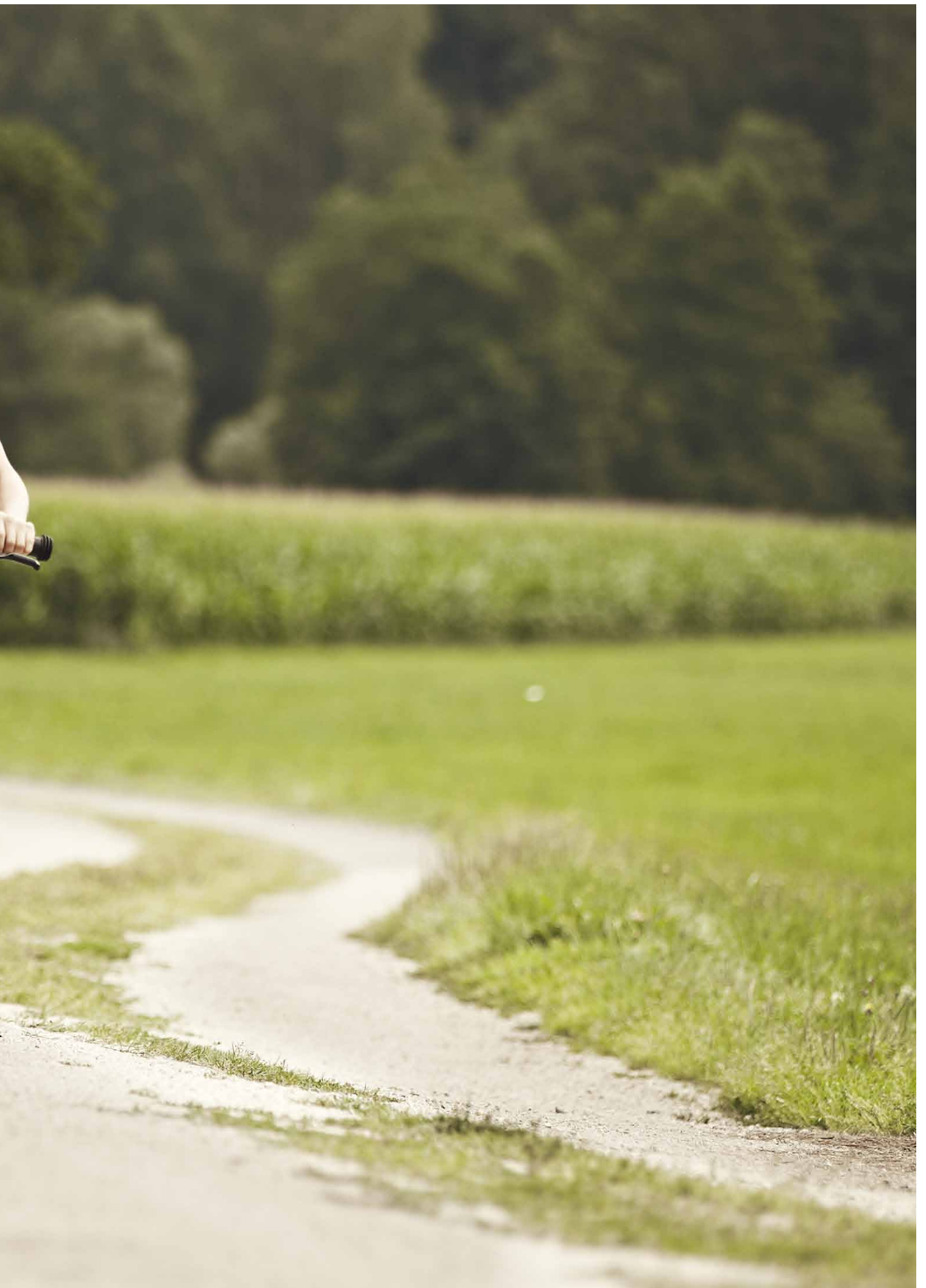

POWERKID 24 BOY

BLACK / WHITE / RED



Unser leichter Alurahmen, eine optimal angepasste Federgabel, sichere Bremsen und leichte Anbauteile: Mit diesem Bike kannst du auf jede Entdeckungsreise gehen. Und dank Shimano 24-Gang-Schaltung verlieren sogar die Berge jeden Schrecken. Für eine perfekte Welt auf zwei Rädern!

Our lightweight aluminum frame, a perfectly tuned suspension fork, safe brakes and lightweight components: This bike can take you on any discovery. The Shimano 24-speed drivetrain makes climbing mountains seem easy. For a perfect world on two wheels.

























	PK 7005 24 PG		Tektro V-Brake
	GHOST light AS-007N 31.8 mm		Impac Outpac 24x2.00
	SR Suntour XCT 50 mm		Impac Outpac 24x2.00
	Ritchey		GHOST 24 Wheelset
	GHOST Low Rizer 580 mm 31.8 mm		GHOST 24 Wheelset
	GHOST light SP DC 1 31.6 mm		GHOST 24 Wheelset
	Velo VL 5026		SRAM PG-820 11-30
	Shimano Altus 8-Speed		50 mm
	Shimano Tourney		34 cm
	Shimano		12.20 kg
	Tektro		
	Alu Triple Speed		
	Alu Triple Speed-		

POWERKID 24 BOY

GREY / WHITE / GREEN



- | | | | |
|--|---|--|---|
|  PK 7005 24 PG |  Shimano Altus 8-Speed |  Impac Outpac 24x2.00 |  50 mm |
|  GHOST light AS-007N 31.8 mm |  Shimano Tourney |  Impac Outpac 24x2.00 |  34 cm |
|  SR Suntour XCT 50 mm |  Shimano |  GHOST 24 Wheelset |  12.20 kg |
|  Ritchey |  Tektro |  GHOST 24 Wheelset | |
|  GHOST Low Rizer 580 mm 31.8 mm |  Alu Triple Speed |  GHOST 24 Wheelset | |
|  GHOST light SP DC 1 31.6 mm |  Alu Triple Speed- |  SRAM PG-820 11-30 | |
|  Velo VL 5026 |  Tektro V-Brake | | |

POWERKID 24 GIRL

WHITE / ORANGE / BLUE

























- | | | | |
|--|---|--|--|
|  PK 7005 24 PG |  Shimano Altus 8-Speed |  Impac Outpac 24x2.00 |  50 mm |
|  GHOST light AS-007N 31.8 mm |  Shimano Tourney |  Impac Outpac 24x2.00 |  34 cm |
|  SR Suntour XCT 50 mm |  Shimano |  GHOST 24 Wheelset |  12.20 kg |
|  Ritchey |  Tektro |  GHOST 24 Wheelset | |
|  GHOST Low Rizer 580 mm 31.8 mm |  Alu Triple Speed |  GHOST 24 Wheelset | |
|  GHOST light SP DC 1 31.6 mm |  Alu Triple Speed- |  SRAM PG-820 11-30 | |
|  Velo VL 5026 |  Tektro V-Brake | | |

POWERKID 24 GIRL

WHITE / PURPLE / PINK



- | | | | |
|--|---|--|---|
|  PK 7005 24 PG |  Shimano Altus 8-Speed |  Impac Outpac 24x2.00 |  50 mm |
|  GHOST light AS-007N 31.8 mm |  Shimano Tourney |  Impac Outpac 24x2.00 |  34 cm |
|  SR Suntour XCT 50 mm |  Shimano |  GHOST 24 Wheelset |  kg 12.20 kg |
|  Ritchey |  Tektro |  GHOST 24 Wheelset | |
|  GHOST Low Rizer 580 mm 31.8 mm |  Alu Triple Speed |  GHOST 24 Wheelset | |
|  GHOST light SP DC 1 31.6 mm |  Alu Triple Speed- |  SRAM PG-820 11-30 | |
|  Velo VL 5026 |  Tektro V-Brake | | |



POWERKID 20 BOY



BLACK / WHITE / RED



-  PK 7005 20 PG
-  GHOST AS-601
-  SR Suntour XCT 40 mm
-  Ritchey
-  GHOST 520 mm
-  GHOST 27.2 mm
-  Velo VL 5026

-  Shimano Tourney 7-Speed
-  Shimano Tourney
-  Tektro
-  Shimano BBUN-26
-  Alu Single Speed
-  Tektro V-Brake

-  Impac Outpac 20x2.00
-  Impac Outpac 20x2.00
-  GHOST 20 Wheelset
-  GHOST 20 Wheelset
-  GHOST 20 Wheelset
-  Shimano 14-28

-  35 mm
-  27 cm
-  kg 10.60 kg

POWERKID 20 BOY

BLACK / WHITE / GREEN



-  PK 7005 20 PG
-  GHOST AS-601
-  SR Suntour XCT 40 mm
-  Ritchey
-  GHOST 520 mm
-  GHOST 27.2 mm
-  Velo VL 5026

-  Shimano Tourney 7-Speed
-  Shimano Tourney
-  Tektro
-  Shimano BBUN-26
-  Alu Single Speed
-  Tektro V-Brake























-  Impac Outpac 20x2.00
-  Impac Outpac 20x2.00
-  GHOST 20 Wheelset
-  GHOST 20 Wheelset
-  GHOST 20 Wheelset
-  Shimano 14-28

-  35 mm
-  27 cm
-  kg 10.60 kg

POWERKID 20 BOY

BLACK / GREEN / BLUE



- | | | | |
|---|---|--|---|
|  PK 7005 20 PG |  Shimano Tourney 7-Speed |  Impac Outpac 20x2.00 |  35 mm |
|  GHOST AS-601 |  Shimano Tourney |  Impac Outpac 20x2.00 |  27 cm |
|  SR Suntour XCT 40 mm |  Tektro |  GHOST 20 Wheelset |  kg 10.60 |
|  Ritchey |  Shimano BBUN-26 |  GHOST 20 Wheelset | |
|  GHOST 520 mm |  Alu Single Speed |  GHOST 20 Wheelset | |
|  GHOST 27.2 mm |  Tektro V-Brake |  Shimano 14-28 | |
|  Velo VL 5026 | | | |

POWERKID 20 GIRL

PINK / ROSE / GREEN



- | | | | |
|--|---|--|--|
|  PK 7005 20 PG |  Shimano Tourney 7-Speed |  Impac Outpac 20x2.00 |  35 mm |
|  GHOST AS-601 |  Shimano Tourney |  Impac Outpac 20x2.00 |  27 cm |
|  SR Suntour XCT 40 mm |  Tektro |  GHOST 20 Wheelset |  kg 10.60 |
|  Ritchey |  Shimano BBUN-26 |  GHOST 20 Wheelset | |
|  GHOST 520 mm |  Alu Single Speed |  GHOST 20 Wheelset | |
|  GHOST 27.2 mm |  Tektro V-Brake |  Shimano 14-28 | |
|  Velo VL 5026 | | | |







POWERKID 20 GIRL



WHITE / RED / GREEN



-  PK 7005 20 PG
-  GHOST A5-601
-  SR Suntour XCT 40 mm
-  Ritchey
-  GHOST 520 mm
-  GHOST 27.2 mm
-  Velo VL 5026

-  Shimano Tourney 7-Speed
-  Shimano Tourney
-  Shimano BBUN-26
-  Shimano BBUN-26
-  Shimano BBUN-26
-  Shimano BBUN-26
-  Shimano BBUN-26

-  Shimano BBUN-26
-  Shimano BBUN-26
-  Shimano BBUN-26
-  Shimano BBUN-26
-  Shimano BBUN-26
-  Shimano BBUN-26
-  Shimano BBUN-26

-  35 mm
-  27 cm
-  kg 10.60 kg



POWERKID 20 GIRL

WHITE / VIOLETT / PINK



-  PK 7005 20 PG
-  GHOST A5-601
-  SR Suntour XCT 40 mm
-  Ritchey
-  GHOST 520 mm
-  GHOST 27.2 mm
-  Velo VL 5026

-  Shimano Tourney 7-Speed
-  Shimano Tourney
-  Shimano BBUN-26
-  Shimano BBUN-26
-  Shimano BBUN-26
-  Shimano BBUN-26
-  Shimano BBUN-26

-  Shimano BBUN-26
-  Shimano BBUN-26
-  Shimano BBUN-26
-  Shimano BBUN-26
-  Shimano BBUN-26
-  Shimano BBUN-26
-  Shimano BBUN-26

-  35 mm
-  27 cm
-  kg 10.60 kg

POWERKID 16 BOY

RED



- 6061 Alu
- JC
- Stahl
- LF
- JC
- Leadtec
- VELO

- V: V-Brake H: Rücktrittbremse
- JM
- Lasco

- Kenda 16
- Alloy 16
- SIX union
- Joytech / KT
- Single Speed

kg 9,8 kg

POWERKID 16 BOY

GREEN / BLUE



- 6061 Alu
- JC
- Stahl
- LF
- JC
- Leadtec
- VELO

- V: V-Brake H: Rücktrittbremse
- JM
- Lasco

- Kenda 16
- Alloy 16
- SIX union
- Joytech / KT
- Single Speed

kg 9,8 kg

POWERKID 16

GIRL

WHITE



- 6061 Alu
- JC
- Stahl
- LF
- JC
- Leadtec
- VELO

- V: V-Brake H: Rücktrittbremse
- JM
- Lasco

- Kenda 16
- Kenda 16
- Alloy 16
- SIX union
- Joytech / KT
- Single Speed

kg 9,8 kg

POWERKID 16

GIRL

PINK



- 6061 Alu
- JC
- Stahl
- LF
- JC
- Leadtec
- VELO

- V: V-Brake H: Rücktrittbremse
- JM
- Lasco

- Kenda 16
- Kenda 16
- Alloy 16
- SIX union
- Joytech / KT
- Single Speed

kg 9,8 kg

POWERKID 16

GIRL

PURPLE



-  6061 Alu
-  JC
-  Stahl
-  LF
-  JC
-  Leadtec
-  VELO

- 
- 
- 
- 
-  Lasco
-  JM
-  V: V-Brake H: Rücktrittbremse

-  Kenda 16
-  Kenda 16
-  Alloy 16
-  SIX union
-  Joytech / KT
-  Single Speed

kg 9,8 kg









POWERKID 12

GREEN



-  6061 Alu
-  JC
-  Stahl
-  LF
-  JC
-  Leadtec
-  VELO

-  V: V-Brake H: Rücktrittbremse
-  JM
-  Lasco
-  JC
-  Leadtec
-  VELO

-  Kenda 12
-  Kenda 12
-  Alloy 12
-  SIX union
-  Joytech / KT
-  Single Speed

-  kg 7,9 kg

POWERKID 12

PURPLE



-  6061 Alu
-  JC
-  Stahl
-  LF
-  JC
-  Leadtec
-  VELO

-  V: V-Brake H: Rücktrittbremse
-  JM
-  Lasco
-  JC
-  Leadtec
-  VELO

-  Kenda 12
-  Kenda 12
-  Alloy 12
-  SIX union
-  Joytech / KT
-  Single Speed

-  kg 7,9 kg

POWERKIDDY

12

GREEN



- 6061 Alu
- JC
- Stahl
- LF
- JC
- Leadtec
- VELO

- Lasco
- JM
- V: V-Brake H: Rücktrittbremse

- Kenda 12
- Kenda 12
- Alloy 12
- SIX union
- Joytech / KT
- Single Speed

- kg 4,8 kg

POWERKIDDY

12

PURPLE



- 6061 Alu
- JC
- Stahl
- LF
- JC
- Leadtec
- VELO

- Lasco
- JM
- V: V-Brake H: Rücktrittbremse

- Kenda 12
- Kenda 12
- Alloy 12
- SIX union
- Joytech / KT
- Single Speed

- kg 4,8 kg

EBS

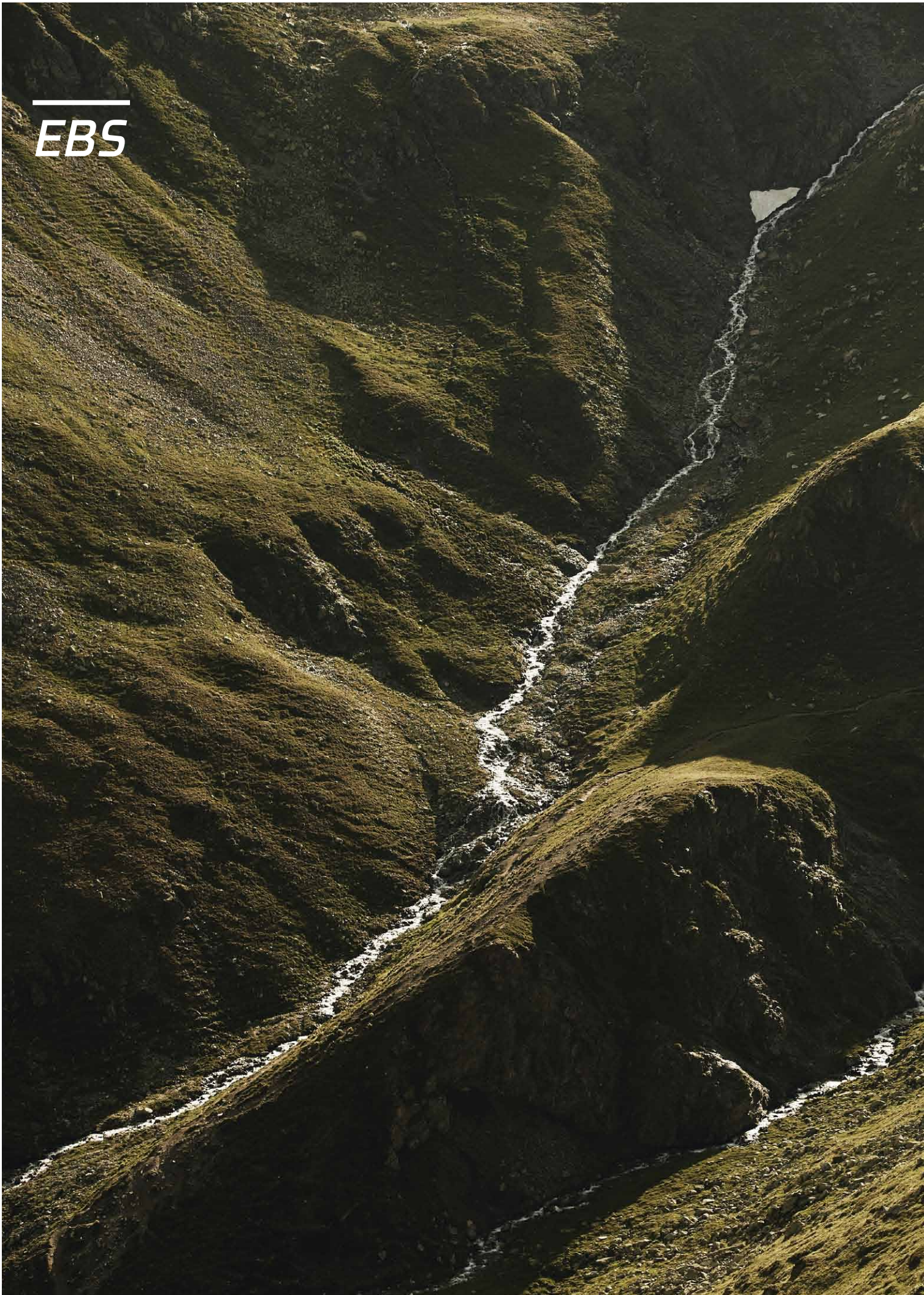

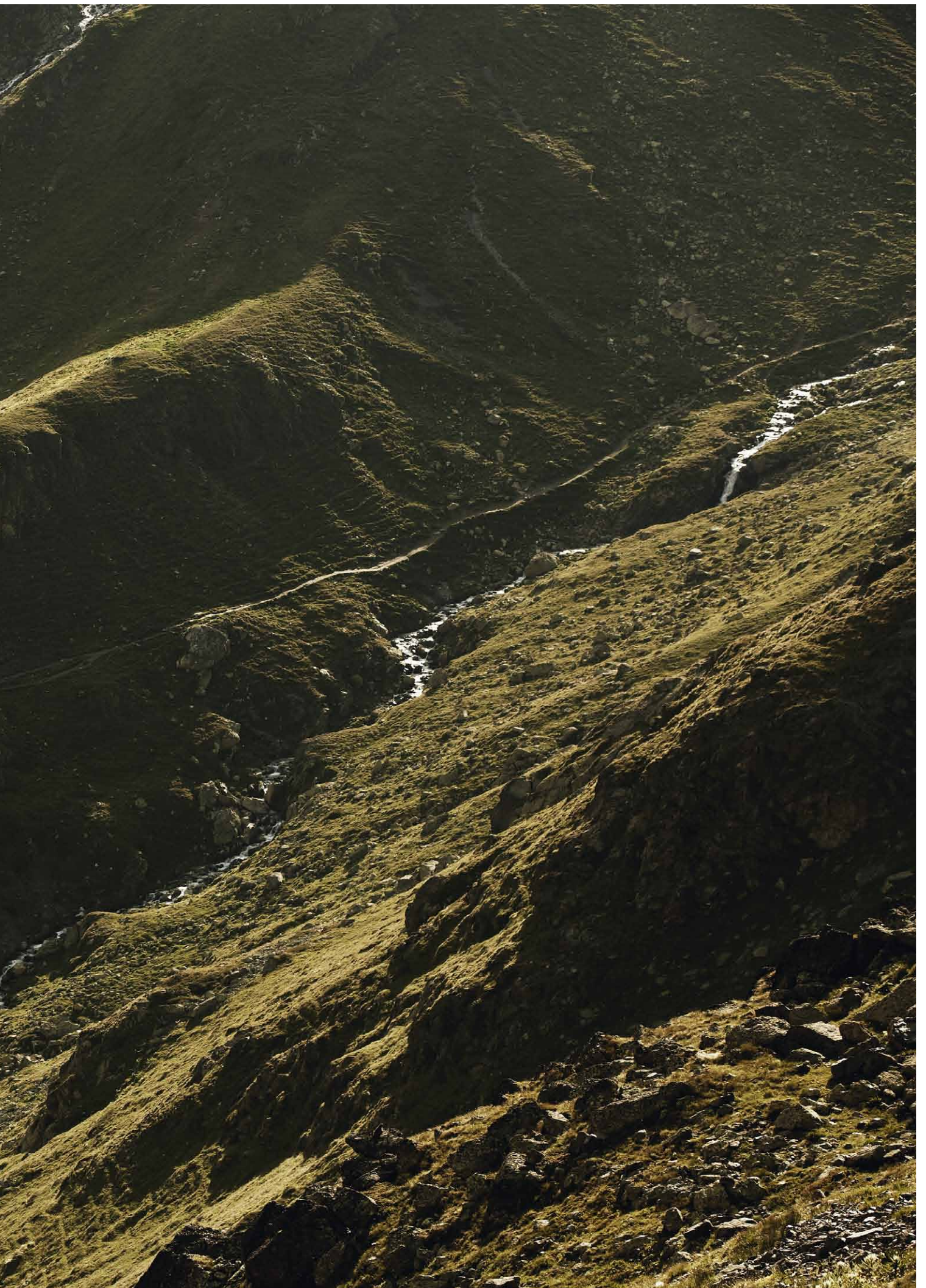

EBS PRO 29

GREY / BLACK / BLUE



THT | TAPERED HEAD TUBE

PM DIRECT

HYDROFORMING TUBESET



















	EBS 29 7005 Tapered		Avid Elixir 1 Disc 180 mm
	GHOST light A5-007N 31.8 mm		Impac Ridgepac 29x2.1
	Rock Shox Recon 29 Silver Air PopLoc 100 mm		Impac Ridgepac 29x2.1
	Ritchey Tapered		Ryde Taurus
	GHOST Flat light 680 mm 31.8 mm		DT Swiss 1.8
	GHOST light SP DC 1 27.2 mm		SRAM 306
	GHOST VL 1535		SRAM PG-1030 11-36
	Shimano XT 10-Speed		100 mm
	Shimano SLX		100 mm
	Shimano Deore SL		100 mm
	Avid Elixir 1		40/44/48/52/56 cm
	Shimano BB51 BSA		kg 12.90 kg
	Shimano XT 42-32-24		

EBS COMP

BLACK / GREY / RED

























 EBS 7005 PG	 Shimano Acera 9-Speed	 Impac Ridgepac 2.1	 100 mm
 GHOST light AS-007N 31.8 mm	 Shimano Acera	 Impac Ridgepac 2.1	 34/40/44/48/52/56 cm
 RST Gila MLO 100 mm	 Shimano Acera SL	 Ryde Taurus	 kg 12.40 kg
 Ritchey	 Tektro HDC 300	 DT Swiss 1.8	
 GHOST Low Rizer light 640 mm 31.8 mm	 Shimano BBES-25	 SRAM 306	
 GHOST light SP DC 1 31.6 mm	 Shimano Acera 44-32-22	 Shimano 11-32	
 GHOST VL 1535	 Tektro HDC 300 Disc 160 mm		

EBS RACE

BLACK / GREY / RED

























 Race Actinum DB AFT	 Shimano Ultegra 10-Speed	 Schwalbe Ultremo	 47/50/53/56/58/60/62 cm
 FSA 190 Laser 31.8 mm	 Shimano Ultegra	 Schwalbe Ultremo	 kg 8.50 kg
 CG Carbon	 Shimano Ultegra	 Shimano Wheelset	
 Ritchey	 Shimano Ultegra	 Shimano Wheelset	
 FSA Road Vero Compact 31.8 mm	 Shimano BB BSA	 Shimano Wheelset	
 GHOST light SP DC 1 27.2 mm	 Shimano FCM 565 Compact 50-34	 Shimano 105 11-28	
 GHOST VL 1411	 Shimano		

EBS TREKKING

BLACK / GREY / RED



- | | | | |
|---|--|--|---|
|  Trekking 7005 PG |  Shimano Altus 8-Speed |  Impac Streetpac 42-622 |  60 mm |
|  Ghost light AS-822 adjustable 25.4 mm |  Shimano Acera |  Impac Streetpac 42-622 |  45/49/53/57/61 cm |
|  RST Neon T 60 mm |  Shimano Altus STI |  Rigida X Star 19 |  15.10 kg |
|  Ritchey |  Shimano Altus STI |  DT Swiss 1.8 | |
|  GHOST 620 mm |  Shimano BBUN-26 |  Shimano Hub Dynamo | |
|  GHOST light SP DC 1 31.6 mm |  Shimano FCM 171 48-38-28 |  SRAM PG-820 11-30 | |
|  Selle Royal Freccia RVL Man |  Tektro V-Brake | | |

EBS TREKKING LADY

BLACK / GREY / RED

























- | | | | |
|---|--|--|--|
|  Trekking 7005 PG |  Shimano Altus 8-Speed |  Impac Streetpac 42-622 |  60 mm |
|  Ghost light AS-822 adjustable 25.4 mm |  Shimano Acera |  Impac Streetpac 42-622 |  40/44/48/52 cm |
|  RST Neon T 60 mm |  Shimano Altus STI |  Rigida X Star 19 |  15.10 kg |
|  Ritchey |  Shimano Altus STI |  DT Swiss 1.8 | |
|  GHOST 620 mm |  Shimano BBUN-26 |  Shimano Hub Dynamo | |
|  GHOST light SP DC 1 31.6 mm |  Shimano FCM 171 48-38-28 |  SRAM PG-820 11-30 | |
|  Selle Royal Freccia RVL Lady |  Tektro V-Brake | | |

EBS TREKKING WAVE

BLACK / GREY / RED



 Trekking 7005 PG	 Shimano Altus 8-Speed	 Impac Streetpac 42-622	 60 mm
 Ghost light AS-822 adjustable 25.4 mm	 Shimano Acera	 Impac Streetpac 42-622	 40/44/48/52 cm
 RST Neon T 60 mm	 Shimano Altus STI	 Rigida X Star 19	 15.30 kg
 Ritchey	 Tektro V-Brake	 DT Swiss 1.8	
 GHOST 620 mm	 Shimano BBUN-26	 Shimano Hub Dynamo	
 GHOST light SP DC 1 31.6 mm	 Shimano FCM 171 48-38-28	 SRAM PG-820 11-30	
 Selle Royal Freccia RVL Lady	 Tektro V-Brake		

Sonderausstattung TR Series: LED Scheinwerfer, LED Rücklicht mit Standfunktion, Klingel, SKS Pumpe und Schutzbleche, Ständer, Kettenkasten
Special Equipment: LED floodlight, LED backlight, bell, SKS airpump and mudguard, kickstand, chaincase





GEOMETRIE GEOMETRY

- A Rahmenhöhe *frame size*
- B Oberrohrlänge *top tube length*
- C Steuerrohrlänge *headtube length*
- D Kettenstrebenlänge *chainstay length*
- E Sitzrohrwinkel *seattube angle*
- F Lenkwinkel *headtube angle*
- G Sattelstützendurchmesser *seat post diameter*
- H Umwerfermass *front derailleur clamp*
- J Federelement Einbaulänge *shock length*
- K Radstand *wheelbase*
- L Tretlagerhöhe *BB height*
- M Überstandshöhe *stand over height*
- N Vorbaulänge *stem length*
- O Effektive Cockpitlänge *effective cockpit length*
- P Reach *reach*
- Q Stack *stack*
- R Lenkerbreite *handlebar width*
- S Kurbellänge *crank length*
- T Min. Schrittlänge *min. inseam*
- U Max. Schrittlänge *max. inseam*
- V Min. Sattelhöhe *min. saddle height*
- W Max. Sattelhöhe *max. saddle height*

AMR Lector

	40	44	48	52	56
	16"	17.5"	19"	20.5"	22"
A	400	440	480	520	560
B	575	585	595	600	610
C	135	135	135	145	145
D	430	435	435	440	440
E	73	73	73	73	73
F	69	69	69	69	69
G	34,9	34,9	34,9	34,9	34,9
H	x	x	x	x	x
J	200	200	200	200	200
K	1090	1105	1115	1125	1135
L	335	335	335	335	335
M	690	725	735	755	765
N	70	80	90	100	110
O	645	665	685	700	720

AMR

	40	44	48	52	56
	16"	17.5"	19"	20.5"	22"
A	400	440	480	520	560
B	575	585	595	600	610
C	135	135	135	145	145
D	430	435	435	440	440
E	73	73	73	73	73
F	69	69	69	69	69
G	31,6	31,6	31,6	31,6	31,6
H	x	x	x	x	x
J	200	200	200	200	200
K	1090	1105	1115	1125	1135
L	335	335	335	335	335
M	690	725	735	755	765
N	70	80	90	100	110
O	645	665	685	700	720

ASX

	40	44	48	52	56
	16"	17.5"	19"	20.5"	22"
A	405	445	480	520	560
B	570	585	595	600	610
C	135	135	135	155	170
D	435	435	435	440	440
E	73	73	73	73	73
F	69	69	69	69	69
G	31,6	31,6	31,6	31,6	31,6
H	34,9	34,9	34,9	34,9	34,9
J	190	190	190	190	190
K	1090	1105	1115	1125	1135
L	335	335	335	335	335
M	705	730	740	765	780
N	60	70	80	90	100
O	630	655	675	690	710

AMR 29

	40	44	48	52	56
	16"	17.5"	19"	20.5"	22"
A	400	440	480	520	560
B	570	590	610	630	650
C	110	110	120	120	120
D	440	440	440	440	440
E	74	74	74	74	74
F	69,5	69,5	69,5	69,5	69,5
G	31,6	31,6	31,6	31,6	31,6
H	x	x	x	x	x
J	190	190	190	190	190
K	1093	1112	1133	1153	1173
L	330	330	330	330	330
M	705	740	760	780	805
N	60	70	80	90	100
O	630	660	690	720	750

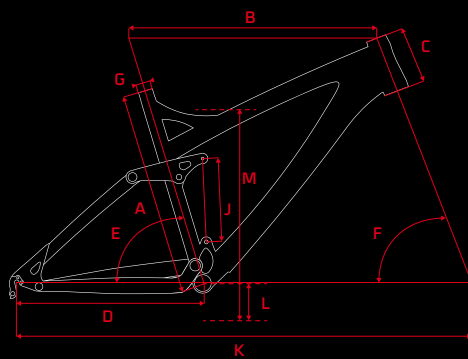

AMR Lector

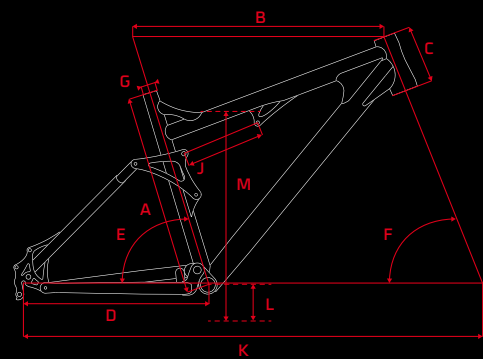

ASX

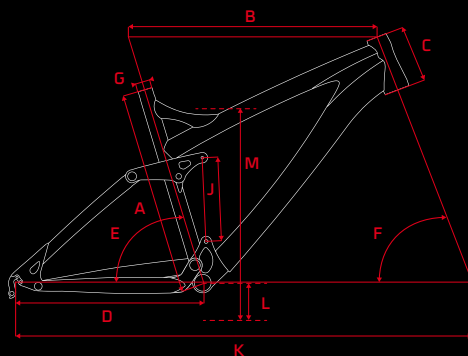

AMR

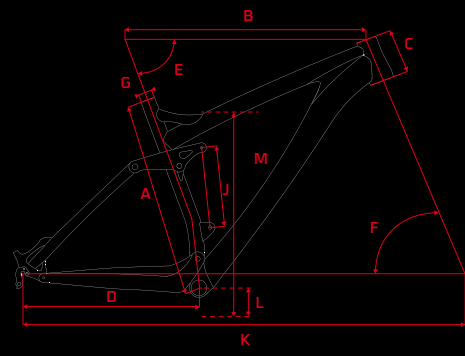

AMR 29 Lector / AMR 29

- A Rahmenhöhe
frame size
- B Oberrohrlänge
top tube length
- C Steuerrohrlänge
headtube length
- D Kettenstrebenlänge
chainstay length
- E Sitzrohrwinkel
seattube angle
- F Lenkwinkel
headtube angle
- G Sattelstützendurchmesser
seat post diameter
- H Umwerfermass
front derailleur clamp
- J Federelement Einbaulänge
shock length
- K Radstand
wheelbase
- L Tretlagerhöhe
BB height
- M Überstandshöhe
stand over height
- N Vorbaulänge
stem length
- O Effektive Cockpitlänge
effective cockpit length
- P Reach
reach
- Q Stack
stack
- R Lenkerbreite
handlebar width
- S Kurbellänge
crank length
- T Min. Schrittlänge
min. inseam
- U Max. Schrittlänge
max. inseam
- V Min. Sattelhöhe
min. saddle height
- W Max. Sattelhöhe
max. saddle height

AMR Plus Lector

	40	44	48	52	56
	16"	17.5"	19"	20.5"	22"
A	400	440	480	520	560
B	585	585	595	605	615
C	115	115	125	125	125
D	435	435	435	440	440
E	74	74	74	74	74
F	67	67	67	67	67
G	34,9	34,9	34,9	34,9	34,9
H	x	x	x	x	x
J	215	215	215	215	215
K	1140	1140	1150	1165	1175
L	335	335	335	335	335
M	700	725	745	765	785
N	60	70	70	80	80
O	645	655	665	685	695

AMR Plus

	40	44	48	52	56
	16"	17.5"	19"	20.5"	22"
A	400	440	480	520	560
B	585	585	595	605	615
C	115	115	125	125	125
D	435	435	435	440	440
E	74	74	74	74	74
F	67	67	67	67	67
G	31,6	31,6	31,6	31,6	31,6
H	x	x	x	x	x
J	215	215	215	215	215
K	1140	1140	1150	1165	1175
L	335	335	335	335	335
M	700	725	745	765	785
N	60	70	70	80	80
O	645	655	665	685	695

Cagua

	40	44	48	52	56
	16"	17.5"	19"	20.5"	22"
A	400	440	480	520	560
B	585	585	595	605	615
C	115	115	125	125	125
D	435	435	435	440	440
E	73,5	73,5	73,5	73,5	73,5
F	66,5	66,5	66,5	66,5	66,5
G	31,6	31,6	31,6	31,6	31,6
H	x	x	x	x	x
J	222	222	222	222	222
K	1150	1150	1160	1175	1185
L	355	355	355	355	355
M	700	725	745	765	785
N	60	60	60	70	70
O	645	645	655	675	685

Cagua 650B

	40	44	48	52	56
	16"	17.5"	19"	20.5"	22"
A	400	440	480	520	560
B	580	590	600	610	620
C	125	125	125	135	135
D	430	430	430	430	430
E	74	74	74	74	74
F	67	67	67	67	67
G	31,6	31,6	31,6	31,6	31,6
H	x	x	x	x	x
J	216	216	216	216	216
K	1139	1149	1159	1170	1180
L	340	340	340	340	340
M	715	745	765	790	805
N	60	60	60	70	70
O	640	650	660	680	690

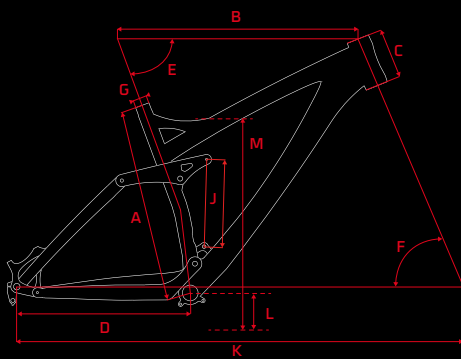

AMR Plus Lector

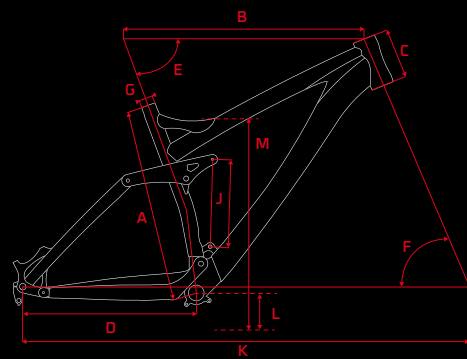

Cagua

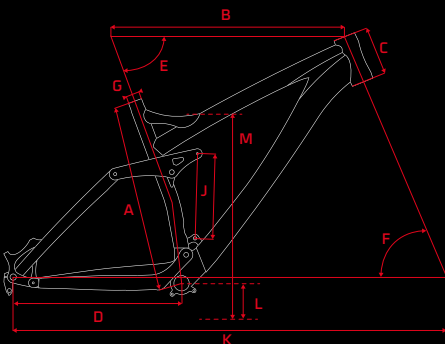

AMR Plus

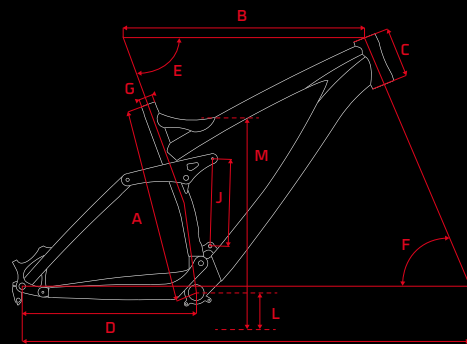

Cagua 650B

GEOMETRIE GEOMETRY

- A Rahmenhöhe *frame size*
- B Oberrohrlänge *top tube length*
- C Steuerrohrlänge *headtube length*
- D Kettenstrebenlänge *chainstay length*
- E Sitzrohrwinkel *seattube angle*
- F Lenkwinkel *headtube angle*
- G Sattelstützendurchmesser *seat post diameter*
- H Umwerfermass *front derailleur clamp*
- J Federelement Einbaulänge *shock length*
- K Radstand *wheelbase*
- L Tretlagerhöhe *BB height*
- M Überstandshöhe *stand over height*
- N Vorbaulänge *stem length*
- O Effektive Cockpitlänge *effective cockpit length*
- P Reach *reach*
- Q Stack *stack*
- R Lenkerbreite *handlebar width*
- S Kurbellänge *crank length*
- T Min. Schrittlänge *min. inseam*
- U Max. Schrittlänge *max. inseam*
- V Min. Sattelhöhe *min. saddle height*
- W Max. Sattelhöhe *max. saddle height*

Northshore

	41	41	41
	S	M	L
A	410	410	410
B	550	570	590
P	390	410	430
Q	605	605	605
C	120	120	120
D	430	430	430
E	58,5	58,5	58,5
F	65	65	65
G	34,9	34,9	34,9
H	x	x	x
J	241	241	241
K	1145	1165	1185
L	350	350	350
M	745	745	745
N	60	60	60
O	610	630	650

Downhill

	40	40	40
	S	M	L
A	400	400	400
B	585	610	635
P	385	410	435
Q	600	600	600
C	120	120	120
D	445	445	445
E	61	61	61
F	63	63	63
G	34,9	34,9	34,9
H	x	x	x
J	267	267	267
K	1180	1205	1230
L	350	350	350
M	725	725	725
N	50	50	50
O	635	660	685

HTX Lector

	40	44	48	52	56
	16"	17.5"	19"	20.5"	22"
A	400	440	480	520	560
B	575	590	605	615	630
C	125	135	135	145	145
D	420	420	425	430	435
E	73	73	72,5	72,5	72
F	70,5	70,5	70,5	70,5	70,5
G	27,2	27,2	27,2	27,2	27,2
H	x	x	x	x	x
J	x	x	x	x	x
K	1055	1070	1085	1100	1115
L	305	305	305	305	305
M	670	695	705	745	760
N	70	80	90	100	110
O	645	670	695	715	740

HTX Actinum

	40	44	48	52	56
	16"	17.5"	19"	20.5"	22"
A	400	440	480	520	560
B	575	590	605	615	630
C	125	135	135	145	145
D	420	420	425	430	435
E	73	73	72,5	72,5	72
F	70,5	70,5	70,5	70,5	70,5
G	27,2	27,2	27,2	27,2	27,2
H	x	x	x	x	x
J	x	x	x	x	x
K	1055	1070	1085	1100	1115
L	305	305	305	305	305
M	670	695	705	745	760
N	70	80	90	100	110
O	645	670	695	715	740

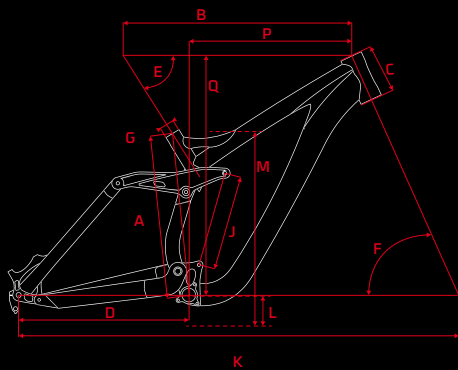

Northshore

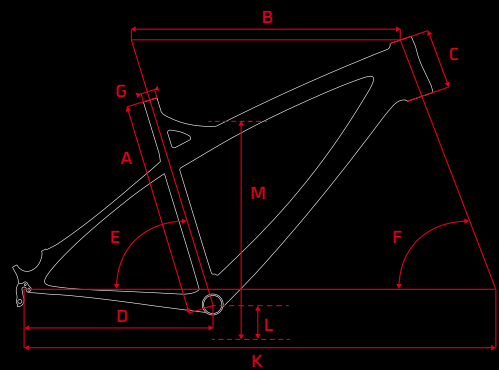

HTX Lector

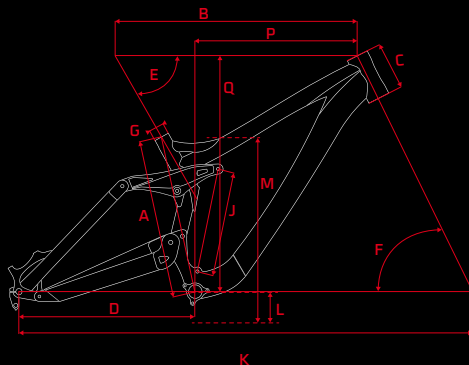

Downhill

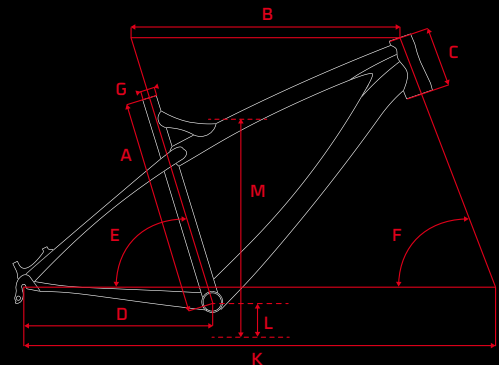

HTX Actinum

- A Rahmenhöhe
frame size
- B Oberrohrlänge
top tube length
- C Steuerrohrlänge
headtube length
- D Kettenstrebenlänge
chainstay length
- E Sitzrohrwinkel
seattube angle
- F Lenkwinkel
headtube angle

- G Sattelstützendurchmesser
seat post diameter
- H Umwerfermass
front derailleur clamp
- J Federelement Einbaulänge
shock length
- K Radstand
wheelbase
- L Tretlagerhöhe
BB height
- M Überstandshöhe
stand over height

- N Vorbaulänge
stem length
- O Effektive Cockpitlänge
effective cockpit length
- P Reach
reach
- Q Stack
stack
- R Lenkerbreite
handlebar width
- S Kurbellänge
crank length

- T Min. Schrittlänge
min. inseam
- U Max. Schrittlänge
max. inseam
- V Min. Sattelhöhe
min. saddle height
- W Max. Sattelhöhe
max. saddle height

HTX 29 Lector

	40	44	48	52	56
	16"	17.5"	19"	20.5"	22"
A	400	440	480	520	560
B	580	590	600	610	620
C	110	110	110	120	120
D	435	435	435	440	440
E	73	73	73	73	73
F	69	69	69	69	69
G	27,2	27,2	27,2	27,2	27,2
H	x	x	x	x	x
J	x	x	x	x	x
K	1080	1090	1100	1115	1125
L	300	300	300	300	300
M	675	700	725	760	780
N	70	80	90	100	110
O	650	670	690	710	730

HTX 29 Actinum

	40	44	48	52	56
	16"	17.5"	19"	20.5"	22"
A	400	440	480	520	560
B	580	590	600	610	620
C	110	110	110	120	120
D	435	435	435	440	440
E	73	73	73	73	73
F	69	69	69	69	69
G	27,2	27,2	27,2	27,2	27,2
H	x	x	x	x	x
J	x	x	x	x	x
K	1080	1090	1100	1115	1125
L	300	300	300	300	300
M	675	700	725	760	780
N	70	80	90	100	110
O	650	670	690	710	730

SE (5000-9000)

	34	40	44	48	52	56
	13.5"	15.5"	17.5"	19"	20.5"	22"
A	340	400	440	480	520	560
B	560	570	580	595	605	620
C	120	120	120	120	150	150
D	425	425	425	425	425	425
E	73,5	73,5	73,5	73	73	72,5
F	71	71	71	71	71	71
G	27,2	27,2	27,2	27,2	27,2	27,2
H	34,9	34,9	34,9	34,9	34,9	34,9
J	x	x	x	x	x	x
K	1040	1050	1060	1070	1080	1095
L	300	300	300	300	300	300
M	610	650	685	700	735	760
N	60	70	80	90	100	110
O	620	640	660	685	705	730

SE (1200-4000)

	34	40	44	48	52	56
	13.5"	15.5"	17.5"	19"	20.5"	22"
A	340	400	440	480	520	560
B	560	570	580	595	605	620
C	115	125	135	135	155	170
D	425	425	425	425	425	425
E	73,5	73,5	73,5	73	73	72,5
F	71	71	71	71	71	71
G	31,6	31,6	31,6	31,6	31,6	31,6
H	34,9	34,9	34,9	34,9	34,9	34,9
J	x	x	x	x	x	x
K	1040	1050	1060	1070	1080	1095
L	300	300	300	300	300	300
M	610	650	685	700	735	775
N	60	70	80	90	100	110
O	620	640	660	685	705	730

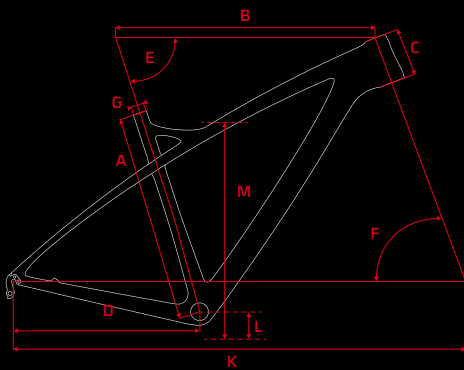

HTX 29 Lector

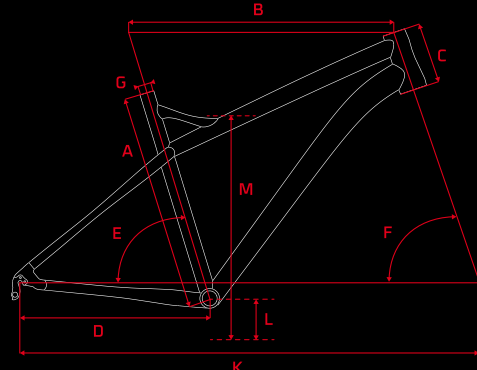

SE (5000-9000)

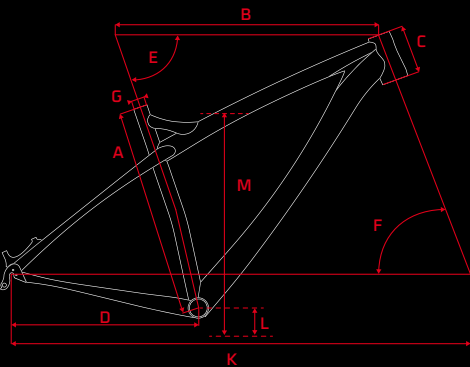

HTX 29 Actinum

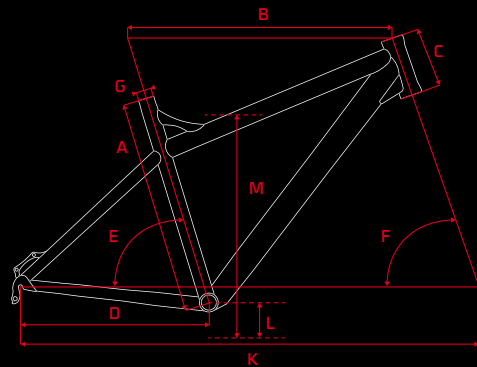

SE (1200-4000)

GEOMETRIE GEOMETRY

- A Rahmenhöhe *frame size*
- B Oberrohrlänge *top tube length*
- C Steuerrohrlänge *headtube length*
- D Kettenstrebenlänge *chainstay length*
- E Sitzrohrwinkel *seat tube angle*
- F Lenkwinkel *headtube angle*
- G Sattelstützendurchmesser *seat post diameter*
- H Umwerfermass *front derailleur clamp*
- J Federelement Einbaulänge *shock length*
- K Radstand *wheelbase*
- L Tretlagerhöhe *BB height*
- M Überstandshöhe *stand over height*
- N Vorbaulänge *stem length*
- O Effektive Cockpitlänge *effective cockpit length*
- P Reach *reach*
- Q Stack *stack*
- R Lenkerbreite *handlebar width*
- S Kurbellänge *crank length*
- T Min. Schrittlänge *min. inseam*
- U Max. Schrittlänge *max. inseam*
- V Min. Sattelhöhe *min. saddle height*
- W Max. Sattelhöhe *max. saddle height*

SE 29

	40	44	48	52	56
	16"	17.5"	19"	20.5"	22"
A	400	440	480	520	560
B	580	590	600	610	620
C	110	110	110	120	120
D	440	440	440	440	440
E	72	72	72	72	72
F	69	69	69	69	69
G	27,2	27,2	27,2	27,2	27,2
H	x	x	x	x	x
J	x	x	x	x	x
K	1080	1090	1100	1110	1120
L	300	300	300	300	300
M	675	700	725	750	770
N	70	80	90	100	110
O	650	670	690	710	730

Dirt

	12,5"
A	320
B	590
C	115
D	390
E	72,5
F	69
G	27,2
H	x
J	x
K	1050
L	320
M	630
N	50
O	640

4Cross

	Comp	Comp	Team
	15"	16,5"	15"
A	380	420	360
B	600	620	580
C	130	130	115
D	430	430	425
E	71	71	71,5
F	69	69	68
G	31,6	31,6	31,6
H	34,9	34,9	x
J	x	x	x
K	1090	1110	1075
L	320	320	310
M	660	700	635
N	50	50	40
O	660	680	620

Miss AMR

	40	44	48	52
	16"	17.5"	19"	20.5"
A	400	440	480	520
B	565	575	580	590
C	135	135	135	135
D	430	430	435	435
E	73	73	73	73
F	69	69	69	69
G	31,6	31,6	31,6	31,6
H	x	x	x	x
J	200	200	200	200
K	1080	1090	1100	1110
L	335	335	335	335
M	690	720	730	750
N	60	70	80	90
O	625	645	660	680

SE 29

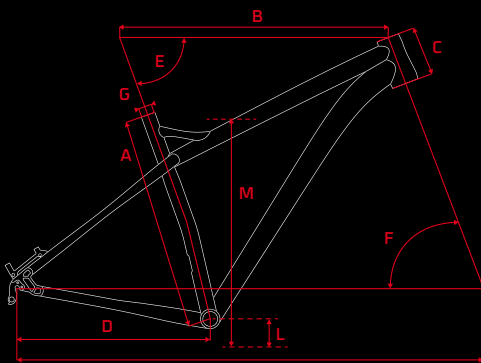

4Cross

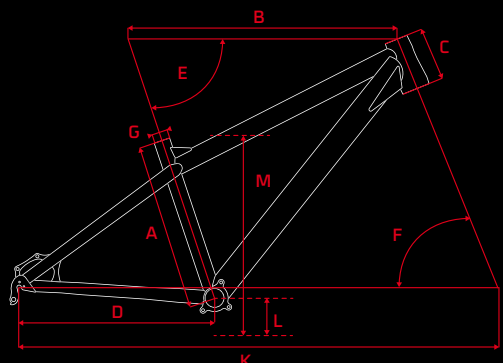

Dirt

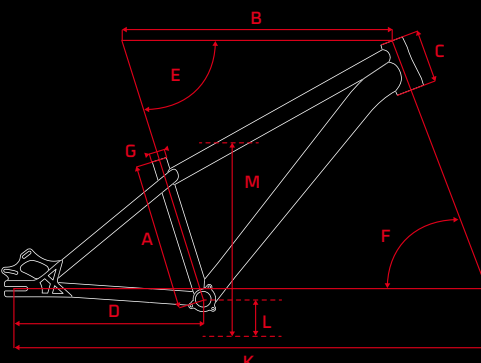

Miss AMR

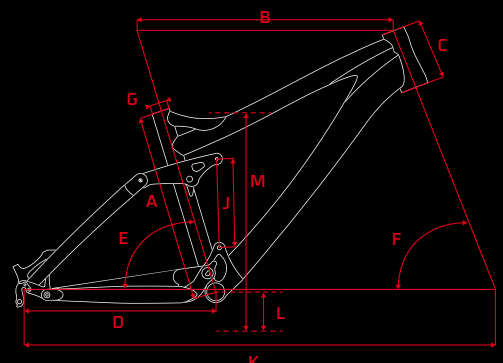

- A Rahmenhöhe *frame size*
- B Oberrohrlänge *top tube length*
- C Steuerrohrlänge *headtube length*
- D Kettenstrebenlänge *chainstay length*
- E Sitzrohrwinkel *seattube angle*
- F Lenkwinkel *headtube angle*
- G Sattelstützendurchmesser *seat post diameter*
- H Umwerfermass *front derailleur clamp*
- J Federelement Einbaulänge *shock length*
- K Radstand *wheelbase*
- L Tretlagerhöhe *BB height*
- M Überstandshöhe *stand over height*
- N Vorbaulänge *stem length*
- O Effektive Cockpitlänge *effective cockpit length*
- P Reach *reach*
- Q Stack *stack*
- R Lenkerbreite *handlebar width*
- S Kurbellänge *crank length*
- T Min. Schrittlänge *min. inseam*
- U Max. Schrittlänge *max. inseam*
- V Min. Sattelhöhe *min. saddle height*
- W Max. Sattelhöhe *max. saddle height*

Miss RT

	40	44	48	52
	16"	17.5"	19"	20.5"
A	405	445	485	525
B	565	575	585	595
C	115	135	135	145
D	430	430	435	435
E	73,5	73,5	73,5	73,5
F	69,5	69,5	69,5	69,5
G	31,6	31,6	31,6	31,6
H	34,9	34,9	34,9	34,9
J	165	165	165	165
K	1075	1085	1100	1110
L	320	320	320	320
M	690	700	720	720
N	60/70	70/80	80/90	90/100
O	625/635	645/655	665/675	685/695

Miss

	34	40	44	48	52
	13.5"	15.5"	17.5"	19"	20.5"
A	340	400	440	480	520
B	550	560	570	590	600
C	115	125	135	135	145
D	425	425	425	425	425
E	73,5	73,5	73,5	73	73
F	71	71	71	71	71
G	31,6	31,6	31,6	31,6	31,6
H	34,9	34,9	34,9	34,9	34,9
J	x	x	x	x	x
K	1030	1040	1050	1065	1075
L	300	300	300	300	300
M	605	640	675	690	725
N	60	70	80	90	100
O	610	630	650	680	700

E-Hybride Trail

	44	48	52
	17.5"	19"	20.5"
A	440	480	520
B	590	600	610
C	160	160	160
D	425	425	425
E	73	73	73
F	69	69	69
G	34,9	34,9	34,9
H	x	x	x
J	x	x	x
K	1100	1110	1120
L	310	310	310
M	700	730	760
N	60	70	80
O	650	670	690

E-Hybride Trail Lady

	44	48	52
	17.5"	19"	20.5"
A	440	480	520
B	580	590	600
C	160	160	160
D	425	425	425
E	73	73	73
F	69	69	69
G	34,9	34,9	34,9
H	x	x	x
J	x	x	x
K	1090	1100	1110
L	310	310	310
M	640	640	660
N	60	70	80
O	485	495	505

Miss RT

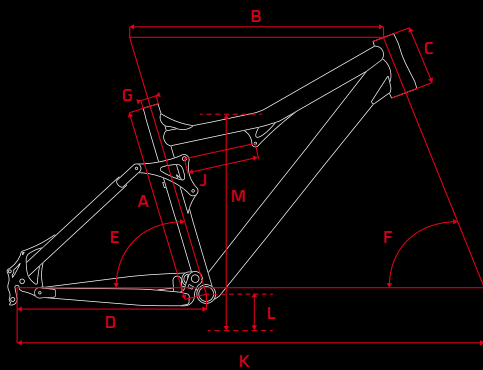

E-Hybride Trail

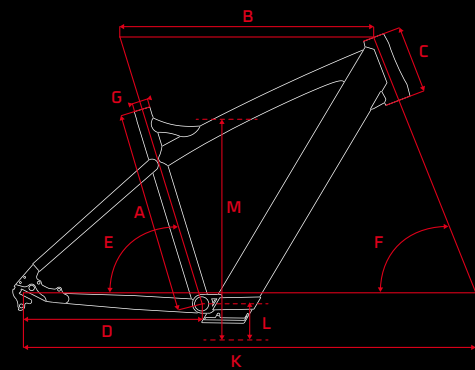

Miss

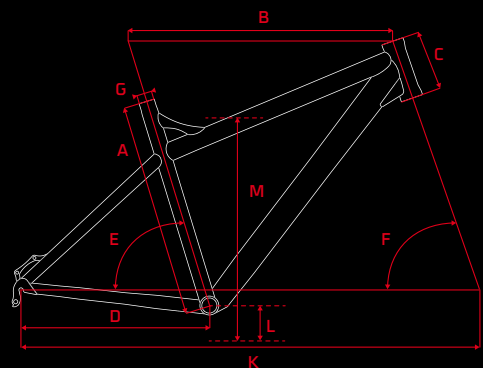

E-Hybride Trail Lady

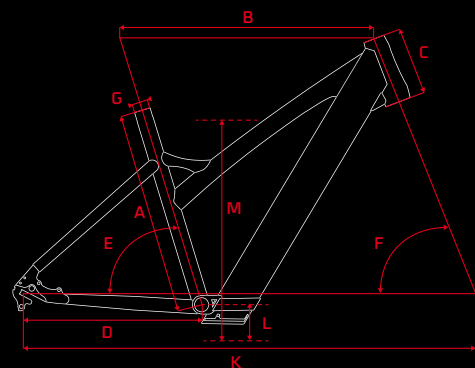

GEOMETRIE GEOMETRY

- A Rahmenhöhe *frame size*
- B Oberrohrlänge *top tube length*
- C Steuerrohrlänge *headtube length*
- D Kettenstrebenlänge *chainstay length*
- E Sitzrohrwinkel *seattube angle*
- F Lenkwinkel *headtube angle*
- G Sattelstützendurchmesser *seat post diameter*
- H Umwerfermass *front derailleur clamp*
- J Federelement Einbaulänge *shock length*
- K Radstand *wheelbase*
- L Tretlagerhöhe *BB height*
- M Überstandshöhe *stand over height*
- N Vorbaulänge *stem length*
- O Effektive Cockpitlänge *effective cockpit length*
- P Reach *reach*
- Q Stack *stack*
- R Lenkerbreite *handlebar width*
- S Kurbellänge *crank length*
- T Min. Schrittlänge *min. inseam*
- U Max. Schrittlänge *max. inseam*
- V Min. Sattelhöhe *min. saddle height*
- W Max. Sattelhöhe *max. saddle height*

E-Hybride Cross

	50	54	58
	M	L	XL
A	490	530	570
B	580	595	610
C	145	155	175
D	465	465	465
E	73	73	73
F	69,5	69,5	69,5
G	27,2	27,2	27,2
H	x	x	x
J	x	x	x
K	1115	1130	1145
L	305	305	305
M	720	755	790
N	70	80	90
O	650	675	700

E-Hybride Cross Lady

	44	48	52
	S	M	L
A	430	470	510
B	560	570	580
C	130	140	160
D	465	465	465
E	73	73	73
F	69,5	69,5	69,5
G	27,2	27,2	27,2
H	x	x	x
J	x	x	x
K	1090	1100	1110
L	305	305	305
M	615	605	600
N	70	80	90
O	630	650	670

E-Hybride Trekking

	50	54	58
	M	L	XL
A	500	540	580
B	580	595	605
C	165	165	195
D	465	465	465
E	73	73	73
F	70,5	70,5	70,5
G	27,2	27,2	27,2
H	x	x	x
J	x	x	x
K	1095	1110	1120
L	290	290	290
M	735	770	805
N	70	80	90
O	650	675	695

E-Hybride Trekking Lady

	44	48	52
	S	M	L
A	440	480	520
B	560	572	584
C	155	160	190
D	465	465	465
E	73	73	73
F	70,5	70,5	70,5
G	27,2	27,2	27,2
H	x	x	x
J	x	x	x
K	1070	1085	1100
L	290	290	290
M	590	580	570
N	70	80	90
O	630	652	674

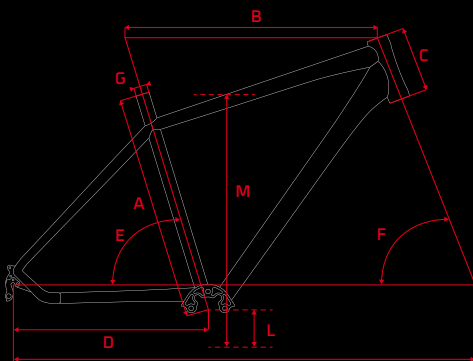

E-Hybride Cross

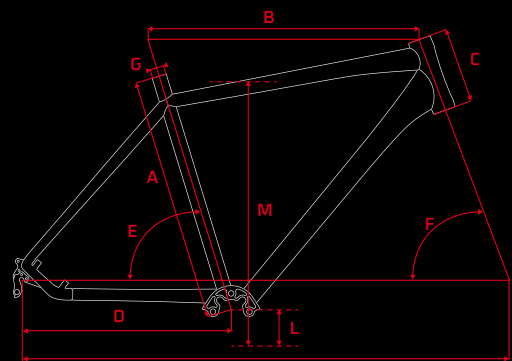

E-Hybride Trekking

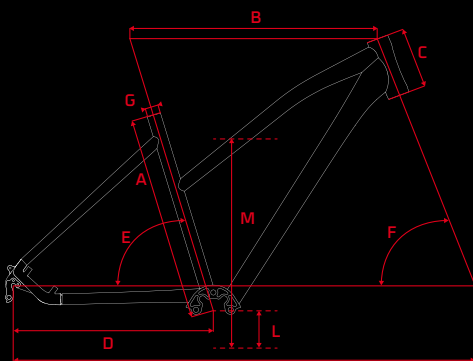

E-Hybride Cross Lady

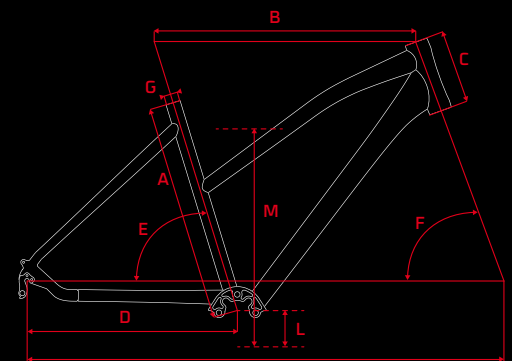

E-Hybride Trekking Lady

A	Rahmenhöhe <i>frame size</i>	G	Sattelstützendurchmesser <i>seat post diameter</i>	N	Vorbaulänge <i>stem length</i>	T	Min. Schrittlänge <i>min. inseam</i>
B	Oberrohrlänge <i>top tube length</i>	H	Umwfermass <i>front derailleur clamp</i>	O	Effektive Cockpitlänge <i>effective cockpit length</i>	U	Max. Schrittlänge <i>max. inseam</i>
C	Steuerrohrlänge <i>headtube length</i>	J	Federelement Einbaulänge <i>shock length</i>	P	Reach <i>reach</i>	V	Min. Sattelhöhe <i>min. saddle height</i>
D	Kettenstrebenlänge <i>chainstay length</i>	K	Radstand <i>wheelbase</i>	Q	Stack <i>stack</i>	W	Max. Sattelhöhe <i>max. saddle height</i>
E	Sitzrohrwinkel <i>seattube angle</i>	L	Tretlagerhöhe <i>BB height</i>	R	Lenkerbreite <i>handlebar width</i>		
F	Lenkwinkel <i>headtube angle</i>	M	Überstandshöhe <i>stand over height</i>	S	Kurbellänge <i>crank length</i>		

E-Hybride Wave

	44	48	52	56
	S	M	L	XL
A	440	480	520	560
B	570	580	590	600
C	145	145	155	155
D	465	465	465	465
E	73	73	73	73
F	69,5	69,5	69,5	69,5
G	27,2	27,2	27,2	27,2
H	x	x	x	x
J	x	x	x	x
K	1100	1110	1125	1135
L	305	305	305	305
M	445	445	445	445
N	90	90	90	90
O	660	670	680	690

Cross (5100-9000)

	45	49	53	57	61
A	450	490	530	570	610
B	570	580	590	605	615
C	135	145	155	175	175
D	440	440	440	440	440
E	73	73	73	73	73
F	70,5	70,5	70,5	71	71
G	27,2	27,2	27,2	27,2	27,2
H	31,8	31,8	31,8	31,8	31,8
J	x	x	x	x	x
K	1065	1075	1085	1095	1105
L	305	305	305	305	305
M	700	735	775	810	850
N	60	70	80	90	100
O	630	650	670	695	715

Cross Lady (5100-9000)

	40	44	48	52
A	400	440	480	520
B	550	560	570	580
C	130	130	140	160
D	440	440	440	440
E	73	73	73	73
F	70,5	70,5	70,5	70,5
G	27,2	27,2	27,2	27,2
H	31,8	31,8	31,8	31,8
J	x	x	x	x
K	1045	1055	1065	1075
L	305	305	305	305
M	590	590	595	605
N	60	70	80	90
O	610	630	650	670

Cross (1300-1800)

	45	49	53	57	61
A	450	490	530	570	610
B	570	580	590	605	615
C	135	145	155	175	175
D	440	440	440	440	440
E	73	73	73	73	73
F	70,5	70,5	70,5	71	71
G	31,6	31,6	31,6	31,6	31,6
H	34,9	34,9	34,9	34,9	34,9
J	x	x	x	x	x
K	1065	1075	1085	1095	1105
L	305	305	305	305	305
M	700	735	775	810	850
N	60	70	80	90	100
O	630	650	670	695	715

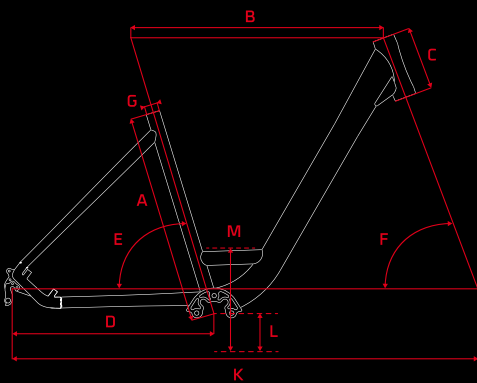

E-Hybride Wave

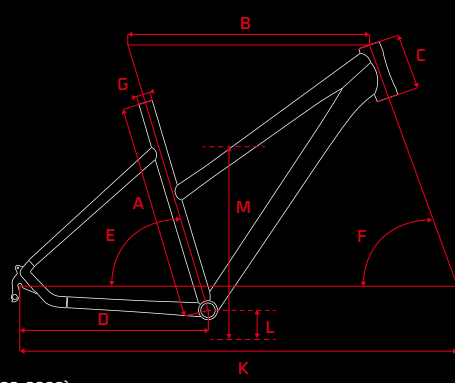

Cross Lady (5100-9000)

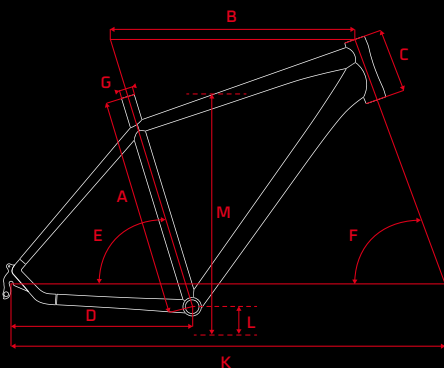

Cross (5100-9000)

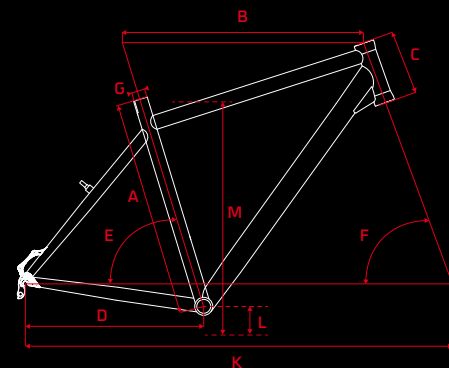

Cross (1300-1800)

GEOMETRIE GEOMETRY

- A Rahmenhöhe *frame size*
- B Oberrohrlänge *top tube length*
- C Steuerrohrlänge *headtube length*
- D Kettenstrebenlänge *chainstay length*
- E Sitzrohrwinkel *seattube angle*
- F Lenkwinkel *headtube angle*
- G Sattelstützendurchmesser *seat post diameter*
- H Umwerfermass *front derailleur clamp*
- J Federelement Einbaulänge *shock length*
- K Radstand *wheelbase*
- L Tretlagerhöhe *BB height*
- M Überstandshöhe *stand over height*
- N Vorbaulänge *stem length*
- O Effektive Cockpitlänge *effective cockpit length*
- P Reach *reach*
- Q Stack *stack*
- R Lenkerbreite *handlebar width*
- S Kurbellänge *crank length*
- T Min. Schrittlänge *min. inseam*
- U Max. Schrittlänge *max. inseam*
- V Min. Sattelhöhe *min. saddle height*
- W Max. Sattelhöhe *max. saddle height*

Cross Lady (1300-1800)

	40	44	48	52
A	400	440	480	520
B	550	560	570	580
C	130	130	140	160
D	440	440	440	440
E	73	73	73	73
F	70,5	70,5	70,5	70,5
G	31,6	31,6	31,6	31,6
H	34,9	34,9	34,9	34,9
J	x	x	x	x
K	1045	1055	1065	1075
L	305	305	305	305
M	590	590	595	605
N	60	70	80	90
O	610	630	650	670

Trekking (5100/5700/7500)

	45	49	53	57	61
A	450	490	530	570	610
B	580	590	600	605	615
C	145	155	155	175	175
D	460	460	460	460	460
E	73	73	73	73	73
F	69,5	69,5	69,5	69,5	69,5
G	27,2	27,2	27,2	27,2	27,2
H	31,8	31,8	31,8	31,8	31,8
J	x	x	x	x	x
K	1105	1115	1125	1135	1145
L	300	300	300	300	300
M	705	740	775	815	850
N	60	70	80	90	100
O	640	660	680	695	715

Trekking rigid fork (5200/7600)

	45	49	53	57	61
A	450	490	530	570	610
B	570	575	590	595	605
C	155	165	165	195	215
D	460	460	460	460	460
E	73	73	73	73	73
F	71	71	71	71	71
G	27	27	27	27	27
H	32	32	32	32	32
J	x	x	x	x	x
K	1075	1085	1095	1105	1115
L	290	290	290	290	290
M	690	730	765	805	840
N	60	70	80	90	100
O	630	645	670	685	705

Trekking Lady (5100/5700)

	40	44	48	52
A	400	440	480	520
B	560	570	580	590
C	135	145	145	155
D	460	460	460	460
E	73	73	73	73
F	69,5	69,5	69,5	69,5
G	27,2	27,2	27,2	27,2
H	31,8	31,8	31,8	31,8
J	x	x	x	x
K	1085	1095	1105	1115
L	300	300	300	300
M	525	525	525	525
N	60	70	80	90
O	620	640	660	680

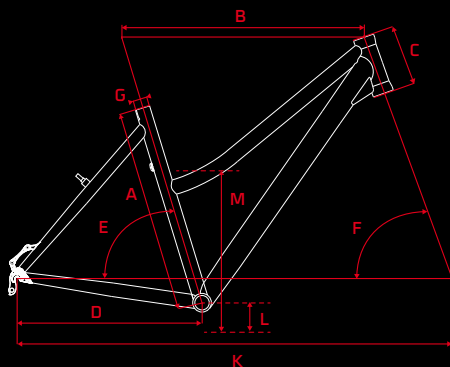

Cross Lady (1300-1800)

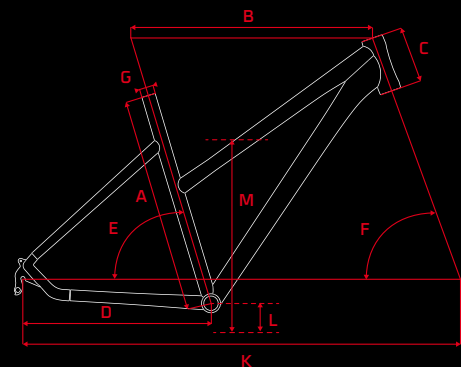

Trekking Lady (5100-5700)

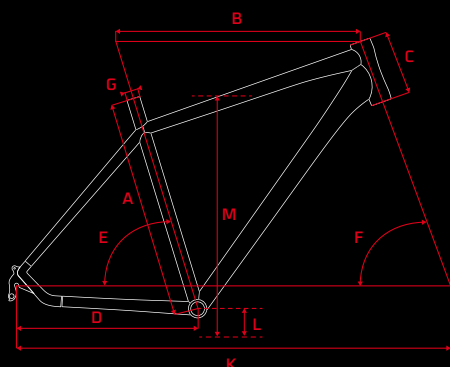

Trekking (5100, 5700, 7500)

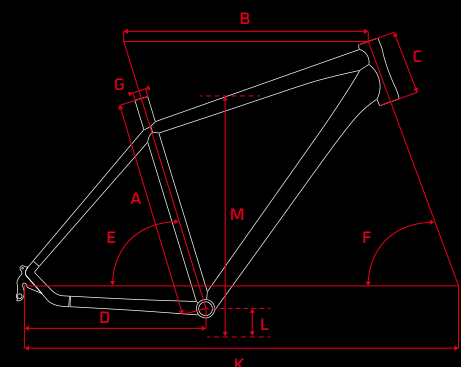

Trekking (5200, 7600)

- A Rahmenhöhe *frame size*
- B Oberrohrlänge *top tube length*
- C Steuerrohrlänge *headtube length*
- D Kettenstrebenlänge *chainstay length*
- E Sitzrohrwinkel *seattube angle*
- F Lenkwinkel *headtube angle*
- G Sattelstützendurchmesser *seat post diameter*
- H Umwerfermass *front derailleur clamp*
- J Federelement Einbaulänge *shock length*
- K Radstand *wheelbase*
- L Tretlagerhöhe *BB height*
- M Überstandshöhe *stand over height*
- N Vorbaulänge *stem length*
- O Effektive Cockpitlänge *effective cockpit length*
- P Reach *reach*
- Q Stack *stack*
- R Lenkerbreite *handlebar width*
- S Kurbellänge *crank length*
- T Min. Schrittlänge *min. inseam*
- U Max. Schrittlänge *max. inseam*
- V Min. Sattelhöhe *min. saddle height*
- W Max. Sattelhöhe *max. saddle height*

Trekking Wave (5100)

	40	44	48	52
A	400	440	480	520
B	560	570	580	590
C	145	145	145	155
D	460	460	460	460
E	73	73	73	73
F	69,5	69,5	69,5	69,5
G	27,2	27,2	27,2	27,2
H	31,8	31,8	31,8	31,8
J	x	x	x	x
K	1085	1095	1105	1115
L	300	300	300	300
M	445	445	445	445
N	90	90	90	90
O	650	665	675	685

Trekking (3500)

	45	49	53	57	61
A	450	490	530	570	610
B	580	590	600	605	615
C	175	185	185	205	205
D	460	460	460	460	460
E	73	73	73	73	73
F	69,5	69,5	69,5	69,5	69,5
G	31,6	31,6	31,6	31,6	31,6
H	34,9	34,9	34,9	34,9	34,9
J	x	x	x	x	x
K	1105	1115	1125	1135	1145
L	300	300	300	300	300
M	700	740	775	815	850
N	90	90	90	110	110
O	670	680	690	715	725

Trekking Lady (3500)

	40	44	48	52
A	400	440	480	520
B	560	570	580	590
C	165	175	175	185
D	460	460	460	460
E	73	73	73	73
F	69,5	69,5	69,5	69,5
G	31,6	31,6	31,6	31,6
H	34,9	34,9	34,9	34,9
J	x	x	x	x
K	1085	1095	1105	1115
L	300	300	300	300
M	525	525	535	545
N	90	90	90	90
O	650	660	670	680

Trekking Wave (3500)

	40	44	48	52
A	400	440	480	520
B	560	570	580	590
C	175	175	175	185
D	460	460	460	460
E	73	73	73	73
F	69,5	69,5	69,5	69,5
G	31,6	31,6	31,6	31,6
H	34,9	34,9	34,9	34,9
J	x	x	x	x
K	1085	1095	1105	1115
L	300	300	300	300
M	445	445	445	445
N	90	90	90	90
O	650	660	670	680

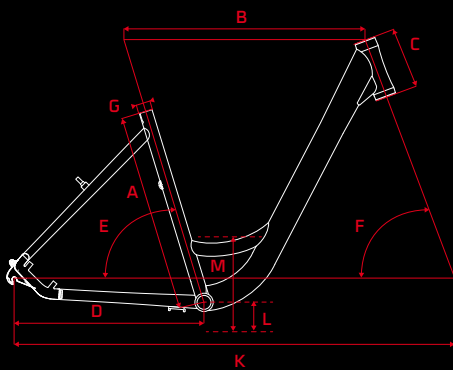

Trekking Wave (5100)

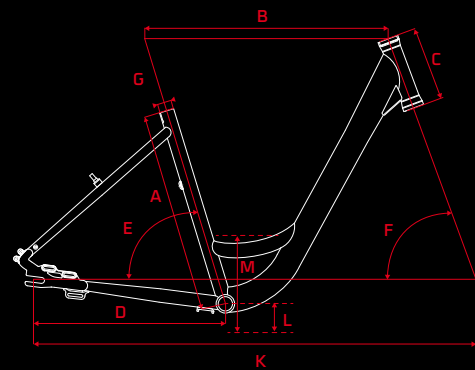

Trekking Wave (3500)

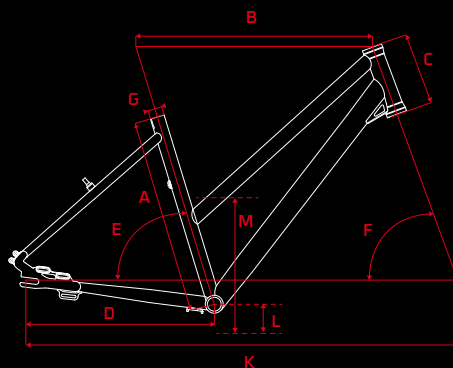

Trekking Lady (3500)

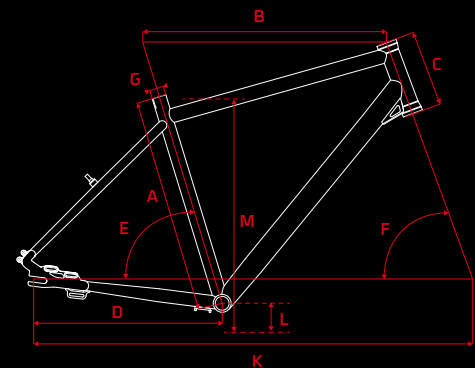

Trekking (3500)

GEOMETRIE GEOMETRY

- A Rahmenhöhe *frame size*
- B Oberrohrlänge *top tube length*
- C Steuerrohrlänge *headtube length*
- D Kettenstrebenlänge *chainstay length*
- E Sitzrohrwinkel *seattube angle*
- F Lenkwinkel *headtube angle*
- G Sattelstützendurchmesser *seat post diameter*
- H Umwerfermass *front derailleur clamp*
- J Federelement Einbaulänge *shock length*
- K Radstand *wheelbase*
- L Tretlagerhöhe *BB height*
- M Überstandshöhe *stand over height*
- N Vorbaulänge *stem length*
- O Effektive Cockpitlänge *effective cockpit length*
- P Reach *reach*
- Q Stack *stack*
- R Lenkerbreite *handlebar width*
- S Kurbellänge *crank length*
- T Min. Schrittlänge *min. inseam*
- U Max. Schrittlänge *max. inseam*
- V Min. Sattelhöhe *min. saddle height*
- W Max. Sattelhöhe *max. saddle height*

Trekking (1300/EBS)

	45	49	53	57	61
A	450	490	530	570	610
B	580	590	600	610	620
C	145	155	155	175	175
D	460	460	460	460	460
E	73	73	73	73	73
F	69,5	69,5	69,5	69,5	69,5
G	31,6	31,6	31,6	31,6	31,6
H	34,9	34,9	34,9	34,9	34,9
J	x	x	x	x	x
K	1105	1115	1125	1135	1145
L	300	300	300	300	300
M	705	740	775	815	850
N	90	90	90	110	110
O	670	680	690	720	730

Trekking rigid fork (1800)

	45	49	53	57	61
A	450	490	530	570	610
B	570	575	590	595	605
C	170	180	180	210	230
D	460	460	460	460	460
E	73	73	73	73	73
F	70,5	70,5	70,5	70,5	70,5
G	31,6	31,6	31,6	31,6	31,6
H	34,9	34,9	34,9	34,9	34,9
J	x	x	x	x	x
K	1075	1085	1095	1105	1115
L	290	290	290	290	290
M	690	730	765	805	840
N	90	90	90	110	110
O	660	665	680	705	715

Trekking Lady (1300/EBS)

	40	44	48	52
A	400	440	480	520
B	560	570	580	590
C	135	145	145	155
D	460	460	460	460
E	73	73	73	73
F	69,5	69,5	69,5	69,5
G	31,6	31,6	31,6	31,6
H	34,9	34,9	34,9	34,9
J	x	x	x	x
K	1085	1095	1105	1115
L	300	300	300	300
M	525	525	525	525
N	90	90	90	90
O	650	660	670	680

Trekking Lady rigid fork (1800)

	40	44	48	52
A	400	440	480	520
B	550	560	570	585
C	160	170	175	205
D	460	460	460	460
E	73	73	73	73
F	70,5	70,5	70,5	70,5
G	31,6	31,6	31,6	31,6
H	34,9	34,9	34,9	34,9
J	x	x	x	x
K	1055	1065	1080	1095
L	290	290	290	290
M	510	510	515	530
N	90	90	90	90
O	640	650	660	675

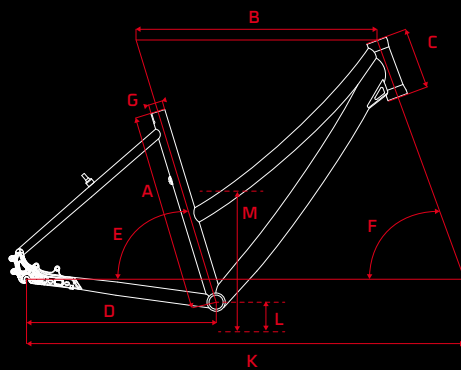

Trekking Lady (1300-1800)

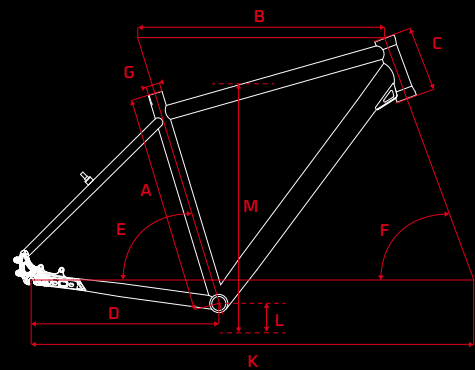

Trekking (1300-1800)

A	Rahmenhöhe <i>frame size</i>	G	Sattelstützendurchmesser <i>seat post diameter</i>	N	Vorbaulänge <i>stem length</i>	T	Min. Schrittlänge <i>min. inseam</i>
B	Oberrohrlänge <i>top tube length</i>	H	Umwerfermass <i>front derailleur clamp</i>	O	Effektive Cockpitlänge <i>effective cockpit length</i>	U	Max. Schrittlänge <i>max. inseam</i>
C	Steuerrohrlänge <i>headtube length</i>	J	Federelement Einbaulänge <i>shock length</i>	P	Reach <i>reach</i>	V	Min. Sattelhöhe <i>min. saddle height</i>
D	Kettenstrebenlänge <i>chainstay length</i>	K	Radstand <i>wheelbase</i>	Q	Stack <i>stack</i>	W	Max. Sattelhöhe <i>max. saddle height</i>
E	Sitzrohrwinkel <i>seattube angle</i>	L	Tretlagerhöhe <i>BB height</i>	R	Lenkerbreite <i>handlebar width</i>		
F	Lenkwinkel <i>headtube angle</i>	M	Überstandshöhe <i>stand over height</i>	S	Kurbellänge <i>crank length</i>		

Trekking Wave (1300/EBS)

	40	44	48	52
A	400	440	480	520
B	560	570	580	590
C	135	145	145	155
D	460	460	460	460
E	73	73	73	73
F	69,5	69,5	69,5	69,5
G	31,6	31,6	31,6	31,6
H	34,9	34,9	34,9	34,9
J	x	x	x	x
K	1085	1095	1105	1115
L	300	300	300	300
M	445	445	445	445
N	90	90	90	90
O	650	665	675	685

Trekking Wave rigid fork (1800)

	40	44	48	52
A	400	440	480	520
B	550	560	570	585
C	160	170	175	205
D	460	460	460	460
E	73	73	73	73
F	70,5	70,5	70,5	70,5
G	31,6	31,6	31,6	31,6
H	34,9	34,9	34,9	34,9
J	x	x	x	x
K	1055	1065	1080	1095
L	290	290	290	290
M	430	430	430	430
N	90	90	90	90
O	640	650	662	674

Race Lector (RED)

	50	53	56	59	62
A	500	530	560	590	620
B	530	540	565	575	590
C	115	140	155	185	210
D	410	410	410	410	410
E	74	74	73,5	73,5	73,5
F	71,5	72	73,5	73,5	73,5
G	31,6	31,6	31,6	31,6	31,6
H	x	x	x	x	x
J	x	x	x	x	x
K	985	990	996	1006	1016
L	270	270	270	270	270
M	710	740	770	800	825
N	80	90	100	110	120
O	610	630	665	685	710
R	420	420	440	440	440
S	170	170	172,5	175	175

Race Lector (7000, PRO, EBS)

	47	50	53	56	59
A	460	490	520	550	580
B	520	532	547	565	585
C	120	140	160	180	200
D	412	412	412	412	412
E	74,5	74	73	72,5	72
F	71,5	72	72,5	73	73
G	27,2	27,2	27,2	27,2	27,2
H	x	x	x	x	x
J	x	x	x	x	x
K	977	981	982	991	1005
L	270	270	270	270	270
M	675	700	730	760	785
N	80	90	100	110	120
O	600	622	647	675	705
R	420	420	420	440	440
S	170	170	172,5	175	175

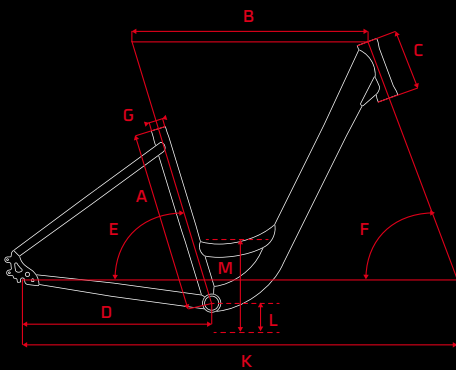

Trekking Wave (1300-1800)

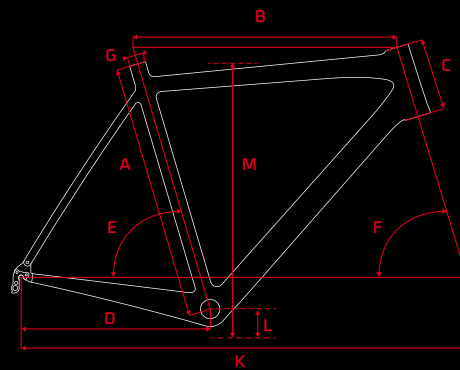

Race Lector (RED)

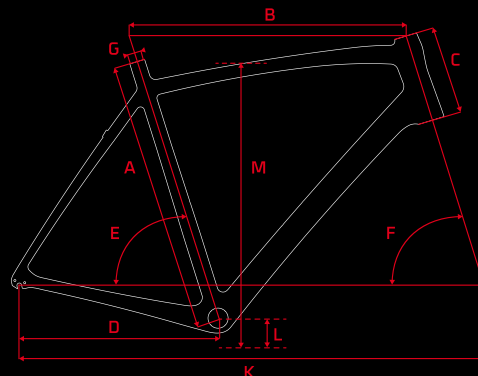

Race Lector (7000, PRO, EBS)

GEOMETRIE GEOMETRY

- | | | | | | | | |
|---|---|---|---|---|---|---|--|
| A | Rahmenhöhe
<i>frame size</i> | G | Sattelstützendurchmesser
<i>seat post diameter</i> | N | Vorbaulänge
<i>stem length</i> | T | Min. Schrittlänge
<i>min. inseam</i> |
| B | Oberrohrlänge
<i>top tube length</i> | H | Umwerfermass
<i>front derailleur clamp</i> | O | Effektive Cockpitlänge
<i>effective cockpit length</i> | U | Max. Schrittlänge
<i>max. inseam</i> |
| C | Steuerrohrlänge
<i>headtube length</i> | J | Federelement Einbaulänge
<i>shock length</i> | P | Reach
<i>reach</i> | V | Min. Sattelhöhe
<i>min. saddle height</i> |
| D | Kettenstrebenlänge
<i>chainstay length</i> | K | Radstand
<i>wheelbase</i> | Q | Stack
<i>stack</i> | W | Max. Sattelhöhe
<i>max. saddle height</i> |
| E | Sitzrohrwinkel
<i>seattube angle</i> | L | Tretlagerhöhe
<i>BB height</i> | R | Lenkerbreite
<i>handlebar width</i> | | |
| F | Lenkwinkel
<i>headtube angle</i> | M | Überstandshöhe
<i>stand over height</i> | S | Kurbellänge
<i>crank length</i> | | |

Race Actinum

	47	50	53	56	58	60	62
A	460	490	520	550	570	590	610
B	521	525	530,5	557,5	576	585	595
C	120	140	148	173	190	210	220
D	404	404	404	404	408	408	408
E	74,3	74,3	74,3	73,7	73,3	73,3	73,3
F	71,7	71,7	71,7	72,7	73,3	73,3	73,3
G	27,2	27,2	27,2	27,2	27,2	27,2	27,2
H	31,8	31,8	31,8	31,8	31,8	31,8	31,8
J	x	x	x	x	x	x	x
K	970	975	980	993	1005	1014	1024
L	270	270	270	270	270	270	270
M	675	690	715	760	780	795	815
N	70	80	90	100	110	120	130
O	591	605	620,5	657,5	686	705	725
R	420	420	420	440	440	440	440
S	170	170	170	170	175	175	175

Speedline Lector

	49	55	59
A	480	540	580
B	570	585	615
C	140	160	180
D	450	450	450
E	72	72	71
F	70	70	71
G	31,6	31,6	31,6
H	34,9	34,9	34,9
J	x	x	x
K	1070	1085	1095
L	300	300	300
M	730	785	820
N	80	90	100
O	650	675	715

Speedline

	49	53	57	61
A	470	510	550	590
B	580	590	605	615
C	165	175	205	240
D	440	440	445	445
E	73	73	73	73
F	70,5	70,5	71	71
G	31,6	31,6	31,6	31,6
H	34,9	34,9	34,9	34,9
J	x	x	x	x
K	1075	1085	1100	1110
L	290	290	290	290
M	705	745	785	820
N	80	90	100	110
O	660	680	705	725

Powerkid 24

	24"
A	340
B	485
C	100
D	410
E	73
F	71
G	31,6
H	34,9
J	x
K	955
L	270
M	555
N	60
O	545
S	152
T	555
U	755

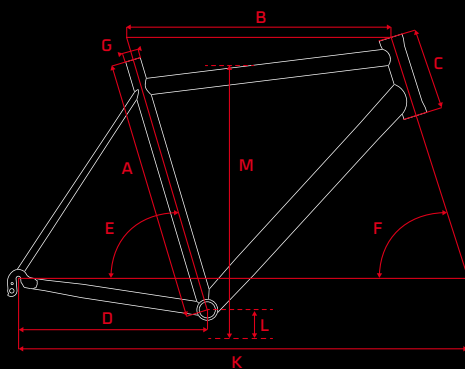

Race Actinum

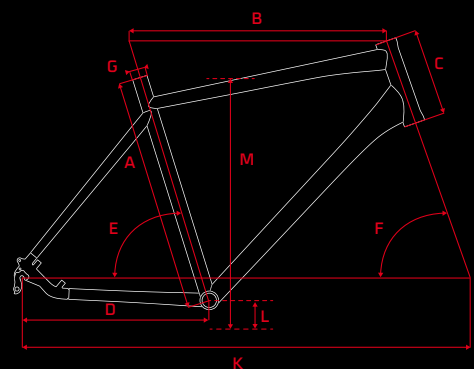

Speedline

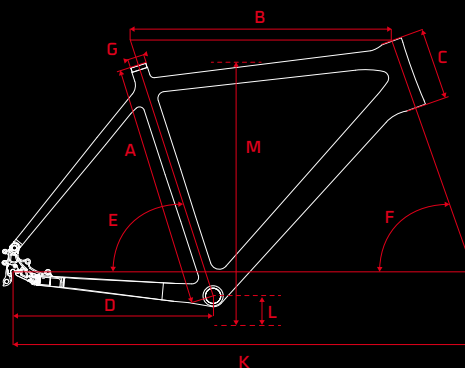

Speedline Lector

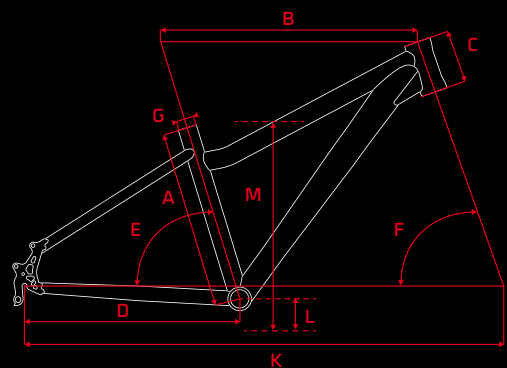

Powerkid 24

A	Rahmenhöhe <i>frame size</i>	G	Sattelstützendurchmesser <i>seat post diameter</i>	N	Vorbaulänge <i>stem length</i>	T	Min. Schrittlänge <i>min. inseam</i>
B	Oberrohrlänge <i>top tube length</i>	H	Umwerfermass <i>front derailleur clamp</i>	O	Effektive Cockpitlänge <i>effective cockpit length</i>	U	Max. Schrittlänge <i>max. inseam</i>
C	Steuerrohrlänge <i>headtube length</i>	J	Federelement Einbaulänge <i>shock length</i>	P	Reach <i>reach</i>	V	Min. Sattelhöhe <i>min. saddle height</i>
D	Kettenstrebenlänge <i>chainstay length</i>	K	Radstand <i>wheelbase</i>	Q	Stack <i>stack</i>	W	Max. Sattelhöhe <i>max. saddle height</i>
E	Sitzrohrwinkel <i>seattube angle</i>	L	Tretlagerhöhe <i>BB height</i>	R	Lenkerbreite <i>handlebar width</i>		
F	Lenkwinkel <i>headtube angle</i>	M	Überstandshöhe <i>stand over height</i>	S	Kurbellänge <i>crank length</i>		

Powerkid 20

20"	
A	270
B	440
C	110
D	350
E	73,5
F	73,5
G	27,2
H	x
J	x
K	840
L	245
M	475
N	60
O	500
S	140
T	485
U	605

Powerkid 16

16"	
A	230
B	380
C	100
D	315
E	73
F	71
G	27,2
H	x
J	x
K	725
L	200
M	395
N	30
O	410
S	115
T	410
U	470

Powerkid 12

12"	
A	180
B	315
C	100
D	240
E	73
F	71
G	27,2
H	x
J	x
K	595
L	160
M	340
N	30
O	345
S	90
T	350
U	400

Powerkiddy 12

12"	
A	165
B	300
C	60
D	295
E	72
F	72
G	27
H	x
J	x
K	563
L	x
M	350
N	35
O	335
V	365
W	430

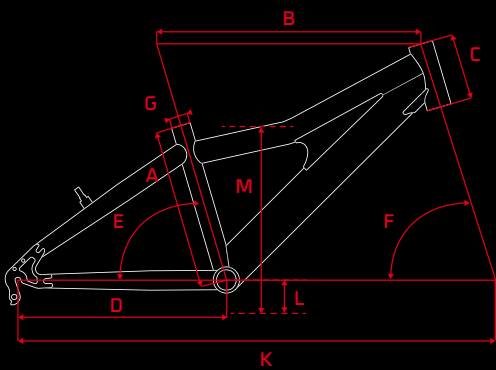

Powerkid 20

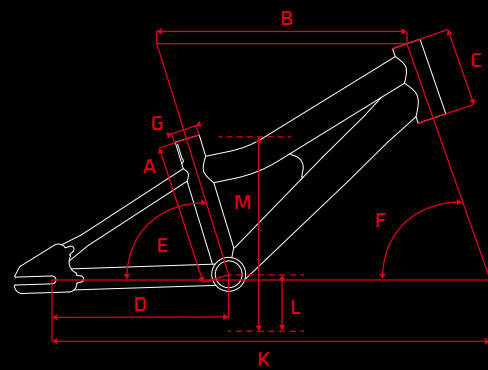

Powerkid 12

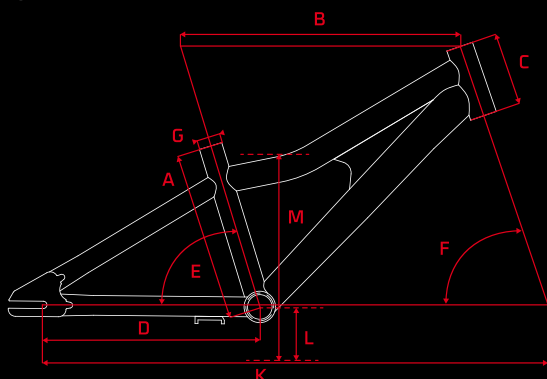

Powerkid 16

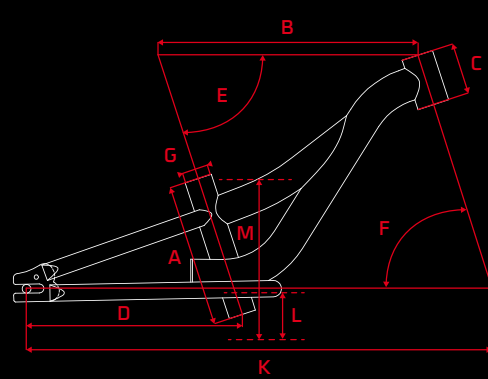

Powerkiddy 12

BEKLEIDUNG & ACCESSOIRES

GEAR & APPAREL





BEKLEIDUNG & ACCESSOIRES

GEAR & APPAREL



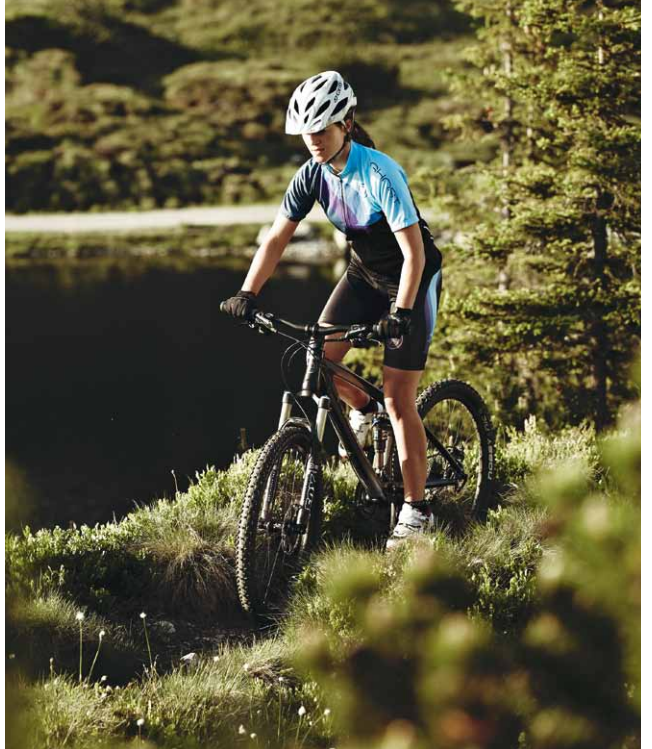

BEKLEIDUNG & ACCESSOIRES

GEAR & APPAREL





BEKLEIDUNG & ACCESSOIRES

GEAR & APPAREL



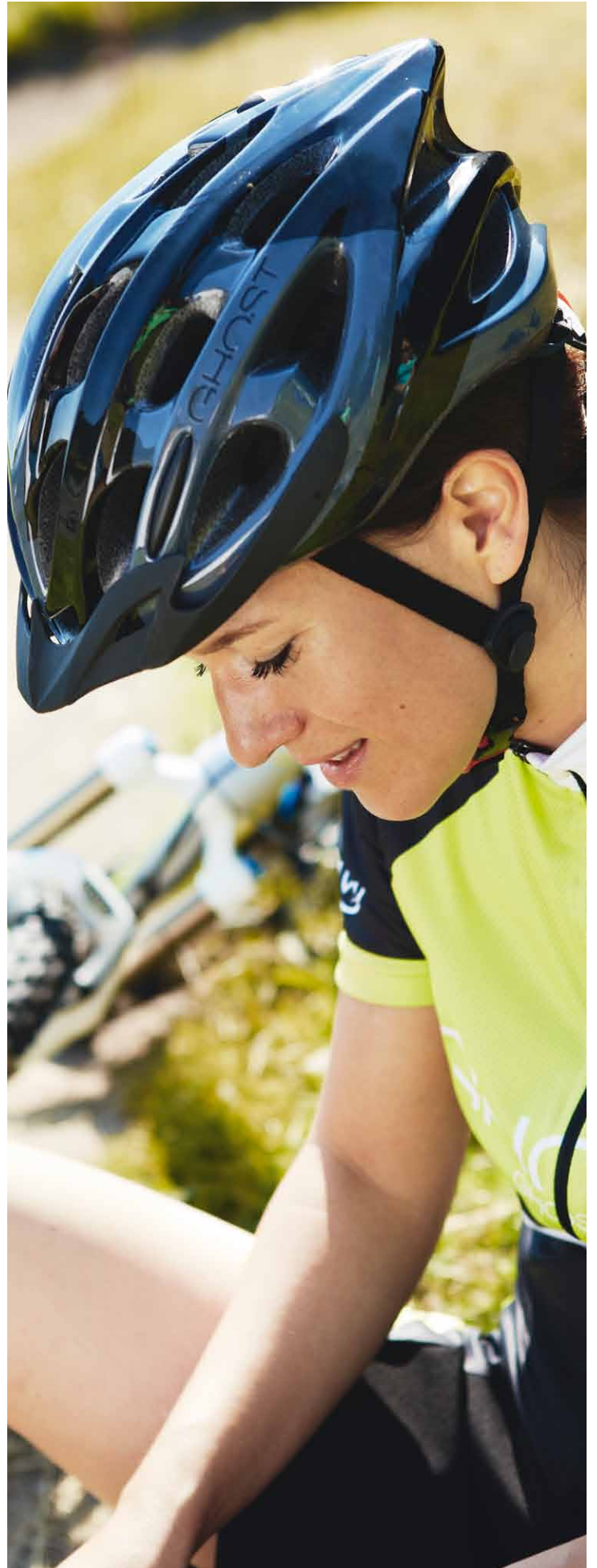

BEKLEIDUNG & ACCESSOIRES

GEAR & APPAREL

BEZEICHNUNG

name





GRÖSSE

size

ARTIKELNUMMER

art. no.

RACE LINE

<p>Jersey short</p> 	<p>red/grey</p> <p>S 101036</p> <p>M 101037</p> <p>L 101038</p> <p>XL 101039</p> <p>XXL 101040</p> <p>XXXL 101041</p>	<p>white/grey</p> <p>S 101042</p> <p>M 101043</p> <p>L 101044</p> <p>XL 101045</p> <p>XXL 101046</p> <p>XXXL 101047</p>	<p>blue/grey</p> <p>S 101048</p> <p>M 101049</p> <p>L 101050</p> <p>XL 101051</p> <p>XXL 101052</p> <p>XXXL 101053</p>
<p>Bib Shorts</p> 	<p>red/grey</p> <p>S 101072</p> <p>M 101073</p> <p>L 101074</p> <p>XL 101075</p> <p>XXL 101076</p> <p>XXXL 101077</p>	<p>white/grey</p> <p>S 101078</p> <p>M 101079</p> <p>L 101080</p> <p>XL 101081</p> <p>XXL 101082</p> <p>XXXL 101083</p>	<p>blue/grey</p> <p>S 101084</p> <p>M 101085</p> <p>L 101086</p> <p>XL 101087</p> <p>XXL 101088</p> <p>XXXL 101089</p>
<p>Bib Tight</p> 	<p>white/grey</p> <p>S 101090</p> <p>M 101091</p> <p>L 101092</p> <p>XL 101093</p> <p>XXL 101094</p> <p>XXXL 101095</p>		
<p>Jersey long</p> 	<p>red/grey</p> <p>S 101054</p> <p>M 101055</p> <p>L 101056</p> <p>XL 101057</p> <p>XXL 101058</p> <p>XXXL 101059</p>	<p>white/grey</p> <p>S 101060</p> <p>M 101061</p> <p>L 101062</p> <p>XL 101063</p> <p>XXL 101064</p> <p>XXXL 101065</p>	<p>blue/grey</p> <p>S 101066</p> <p>M 101067</p> <p>L 101068</p> <p>XL 101069</p> <p>XXL 101070</p> <p>XXXL 101071</p>
<p>Jersey Factory Racing short</p> 	<p>white/red</p> <p>S 91237</p> <p>M 91238</p> <p>L 91239</p> <p>XL 91240</p> <p>XXL 91241</p>		

BEZEICHNUNG

name

GRÖSSE

size

ARTIKELNUMMER

art. no.

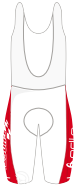
Bib Shorts Factory Racing 	white/red S 91245 M 91244 L 91246 XL 91247 XXL 91248		
RACE LINE LADY			
Jersey Lady short 	brown/pink/ green XS 101132 S 101133 M 101134 L 101135 XL 101136	dark blue/blue XS 101137 S 101138 M 101139 L 101140 XL 101141	
Jersey Lady long 	brown/pink/ green XS 101142 S 101143 M 101144 L 101145 XL 101146	dark blue/blue XS 101147 S 101148 M 101149 L 101150 XL 101151	
Shorts Lady 	brown/pink/ green XS 101152 S 101153 M 101154 L 101155 XL 101156	dark blue/blue XS 101157 S 101158 M 101159 L 101160 XL 101161	

BEKLEIDUNG & ACCESSOIRES



GEAR & APPAREL

BEZEICHNUNG
name

GRÖSSE
size

ARTIKELNUMMER
art. no.

ALL MOUNTAIN

<p>Jersey AM short</p> 	<p>blue/white</p> <p>S 101162</p> <p>M 101163</p> <p>L 101164</p> <p>XL 101165</p> <p>XXL 101166</p> <p>XXXL 101167</p>	<p>black/red</p> <p>S 101168</p> <p>M 101169</p> <p>L 101170</p> <p>XL 101171</p> <p>XXL 101172</p> <p>XXXL 101173</p>	
<p>Jersey AM long</p> 	<p>blue/white</p> <p>S 101174</p> <p>M 101175</p> <p>L 101176</p> <p>XL 101177</p> <p>XXL 101178</p> <p>XXXL 101179</p>	<p>black/red</p> <p>S 101180</p> <p>M 101181</p> <p>L 101182</p> <p>XL 101183</p> <p>XXL 101184</p> <p>XXXL 101185</p>	
<p>Shorts AM</p> 	<p>blue/black/white</p> <p>S 101195</p> <p>M 101196</p> <p>L 101197</p> <p>XL 101198</p> <p>XXL 101199</p>	<p>black/grey/red</p> <p>S 101186</p> <p>M 101187</p> <p>L 101188</p> <p>XL 101189</p> <p>XXL 101190</p>	

ALL MOUNTAIN LADY

<p>Shorts AM Lady</p> 	<p>brown/black/white</p> <p>XS 101200</p> <p>S 101201</p> <p>M 101202</p> <p>L 101203</p> <p>XL 101204</p>	<p>black/blue</p> <p>XS 101277</p> <p>S 101278</p> <p>M 101279</p> <p>L 101280</p> <p>XL 101281</p>	
---	--	---	--

BEZEICHNUNG

name

GRÖSSE

size

ARTIKELNUMMER

art. no.

RACE ACCESSOIRES

<p>Arm warmers</p> 	<p>black/white</p> <p>XS 101205</p> <p>S 101206</p> <p>M 101207</p> <p>L 101208</p> <p>XL 101209</p>		
<p>Leg warmers</p> 	<p>black/white</p> <p>XS 101210</p> <p>S 101211</p> <p>M 101212</p> <p>L 101213</p> <p>XL 101214</p>		
<p>Shoe cover</p> 	<p>black/white</p> <p>38/39 101215</p> <p>40/41 101216</p> <p>42/43 101217</p> <p>44/45 101218</p>		
<p>Helmet</p> 	<p>black</p> <p>M 91001</p> <p>L 91002</p>		
<p>All Mountain Gloves</p> 	<p>green</p> <p>S 91201</p> <p>M 91202</p> <p>L 91203</p> <p>XL 91204</p> <p>XXL 91205</p>	<p>blue</p> <p>S 91206</p> <p>M 91207</p> <p>L 91208</p> <p>XL 91209</p> <p>XXL 91210</p>	<p>black</p> <p>S 91211</p> <p>M 91212</p> <p>L 91213</p> <p>XL 91214</p> <p>XXL 91215</p>

BEKLEIDUNG & ACCESSOIRES

GEAR & APPAREL

BEZEICHNUNG

name

GRÖSSE

size

ARTIKELNUMMER

art. no.

JACKETS

<p>ZipHoody</p> 	<p>classic black/red</p> <p>S 101219 M 101220 L 101221 XL 101222 XXL 101223</p>	<p>blue</p> <p>S 101224 M 101225 L 101226 XL 101227 XXL 101228</p>	
<p>ZipHoody Lady</p> 	<p>navy</p> <p>XS 101239 S 101240 M 101241 L 101242 XL 101243</p>		
<p>Softshell Jacket</p> 	<p>Classic</p> <p>S 101244 M 101245 L 101246 XL 101247 XXL 101248</p>	<p>Casual</p> <p>S 101249 M 101250 L 101251 XL 101252 XXL 101253</p>	
<p>Softshell Jacket Lady</p> 	<p>Classic</p> <p>XS 101254 S 101255 M 101256 L 101257 XL 101258</p>		
<p>Wind Jacket</p> 	<p>red/grey</p> <p>S 101096 M 101097 L 101098 XL 101099 XXL 101100 XXXL 101101</p>	<p>white/grey</p> <p>S 101102 M 101103 L 101104 XL 101105 XXL 101106 XXXL 101107</p>	<p>blue/grey</p> <p>S 101108 M 101109 L 101110 XL 101111 XXL 101112 XXXL 101113</p>

BEZEICHNUNG





name

GRÖSSE

size

ARTIKELNUMMER

art. no.

<p>Winter Jacket</p> 	<p>red/grey</p> <p>S 101114</p> <p>M 101115</p> <p>L 101116</p> <p>XL 101117</p> <p>XXL 101118</p> <p>XXXL 101119</p>	<p>white/grey</p> <p>S 101120</p> <p>M 101121</p> <p>L 101122</p> <p>XL 101123</p> <p>XXL 101124</p> <p>XXXL 101125</p>	<p>blue/grey</p> <p>S 101126</p> <p>M 101127</p> <p>L 101128</p> <p>XL 101129</p> <p>XXL 101130</p> <p>XXXL 101131</p>
<p>LIFESTYLE LINE</p>			
<p>T-Shirt</p> 	<p>brickset white</p> <p>S 101026</p> <p>M 101027</p> <p>L 101028</p> <p>XL 101029</p> <p>XXL 101030</p> <p>fiction dark blue</p> <p>S 101031</p> <p>M 101032</p> <p>L 101033</p> <p>XL 101034</p> <p>XXL 101035</p>	<p>classic black</p> <p>S 101021</p> <p>M 101022</p> <p>L 101023</p> <p>XL 101024</p> <p>XXL 101025</p> <p>hulk green</p> <p>S 101008</p> <p>M 101009</p> <p>L 101013</p> <p>XL 101014</p> <p>XXL 101015</p>	<p>classic light grey</p> <p>S 101016</p> <p>M 101017</p> <p>L 101018</p> <p>XL 101019</p> <p>XXL 101020</p> <p>retro blue</p> <p>S 101003</p> <p>M 101004</p> <p>L 101005</p> <p>XL 101006</p> <p>XXL 101007</p>
<p>T-Shirt Lady</p> 	<p>A-Line dark blue</p> <p>X5 101229</p> <p>S 101230</p> <p>M 101231</p> <p>L 101232</p> <p>XL 101233</p>	<p>Front Tee grey</p> <p>X5 101234</p> <p>S 101235</p> <p>M 101236</p> <p>L 101237</p> <p>XL 101238</p>	
<p>Socks</p> 	<p>white</p> <p>35-38 71087</p> <p>39-42 71088</p> <p>43-45 71089</p> <p>46-48 71090</p>	<p>black</p> <p>35-38 71092</p> <p>39-42 71093</p> <p>43-45 71094</p> <p>46-48 71095</p>	

BEKLEIDUNG & ACCESSOIRES

GEAR & APPAREL

BEZEICHNUNG







name

GRÖSSE



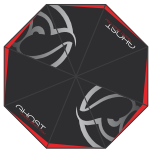
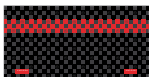



size

ARTIKELNUMMER

art. no.

<p>Beanie</p> 	<p>Classic black uni size</p> <p>Knit man uni size</p> <p>Knit long black uni size</p>	<p>Classic blue uni size</p> <p>Knit Lady uni size</p> <p>Knit long blue uni size</p>	<p>101259</p> <p>101261</p> <p>101263</p> <p>101260</p> <p>101262</p> <p>101264</p>
<p>Trucker Cap</p> 	<p>black uni size</p>	<p>blue uni size</p>	<p>101266</p> <p>101267</p>
<h2>ACCESSOIRES</h2>			
<p>Umbrella</p> 			<p>101002</p>
<p>Muffler</p> 			<p>81149</p>
<p>Canopy -ohne Seitenwand-</p> 	<p>(3x3m)</p>		<p>91038</p>
<p>Banner</p> 	<p>(0,65x2,5m)</p>		<p>91263</p>
<p>Wing Banner</p> 	<p>small (2,05m)</p>	<p>big (3m)</p>	<p>91265</p> <p>61188</p>

BEZEICHNUNG*name***GRÖSSE***size***ARTIKELNUMMER***art. no.*

BEZEICHNUNG <i>name</i>	GRÖSSE <i>size</i>	ARTIKELNUMMER <i>art. no.</i>		
Travel Bag 	95 L	91289		
Backpack 	26 L	91290		
Wash Center 		91297		
Bike Backpack 	11 L	91298		
Badge holder black/white 		91303		
Water bottle 		101001		

TECH LEXIKON

TECHNICAL DICTIONARY

GHOST / Allgemein	UHM HM	Ultra Hochmodulare Carbonfasern 30-40 Tonnen Zugfestigkeit Hochmodulare Carbonfasern 24 Tonnen Zugfestigkeit
Shimano	Shimano CL Shimano STI Hollowtech Octalink 2 Piece Crankset	Centerlock Standard zur Bremsscheibenbefestigung Schalt-/Bremshebel sind in eine Einheit integriert Hohlgeschmiedete, besonders leichte Kurbeln Kurbeln/Innenlager sind über eine spezielle Verzahnung verbunden Kurbel mit integriertem Innenlager
Suspension	LO/Lockout Remote LO Compression Rebound Preload Plattform	Blockiermöglichkeit an Federgabel oder Stoßdämpfer Blockiermöglichkeit vom Lenker Druckstufe - Ölflusskontrolle beim Einfedern Zugstufe - Ölflusskontrolle beim Ausfedern Vorspannung - Abstimmungsmöglichkeiten bei Stahlfederelementen Anti-Wipp-System
FOX	CTD FIT Talas Kashima	Climb (Klettern) - Trail (Plattform) - Descent (Abfahrt) Optimierte Dämpfungskartusche Externe 2-stufige Federwegsverstellung Spezialbeschichtung für Federgabel und Dämpfer
RockShox	PopLoc Motion Control E:i	Lenkerhebel zur Bedienung des Motion Control Lockout Funktion mit Überdruckventil Intelligentes elektronisches Dämpfungssystem
X-Fusion	RL RLR RC RCX	Rebound-Lockout Rebound-Lockout-Remote Rebound-Compression 4 Position Compression-Rebound
<i>GHOST / general</i>	<i>UHM HM</i>	<i>Ultra high-modulus carbon fibers, 30-40 ton tensile strength High-modulus carbon fibers, 24 ton tensile strength</i>
<i>Shimano</i>	<i>Shimano CL Shimano STI Hollowtech Octalink 2 Piece Crankset</i>	<i>Center lock standard for disc brake mounting Shifter / brake lever are integrated into one unit Hollow-forged, extremely lightweight cranks Crank/inner bearings are linked with a special gearing Crank with integrated inner bearing</i>
<i>Suspension</i>	<i>LO/Lockout Remote LO Compression Rebound Preload Plattform</i>	<i>Lock out at suspension fork or shock Remote handlebar lockout Compression phase - oil flow control during compression Rebound phase - oil flow control during rebound Preload - tuning options for steel spring suspension elements Anti-bobbing system</i>
<i>FOX</i>	<i>CTD FIT Talas Kashima</i>	<i>Climb - Trail - Descent Optimized damper cartridge External 2 or 3 stage suspension travel adjustment Special coating for suspension fork and shock</i>
<i>RockShox</i>	<i>PopLoc Motion Control E:i</i>	<i>Handlebar lever for motion control Lockout function with pressure relief valve Intelligent electronic shock system</i>
<i>X-Fusion</i>	<i>RL RLR RC RCX</i>	<i>Rebound/Lockout Rebound/Lockout/Remote Rebound/Compression 4 Position Compression/Rebound</i>

**Kitzbüheler
Alpen**

Brixen i.T. - Kirchberg - Westendorf



22. - 29.06. 2013

KitzAlpBike Mountainbike Festival

www.kitzalpbike.at

- 22. Juni Cross Country, Kirchberg
- 23. Juni Cross Country, Kirchberg
- 26. Juni HillClimb, Brixen im Thale
- 29. Juni KitzAlpBike Mountainbike Marathon, Kirchberg/Brixen/Westendorf
Mountainbike Marathon Weltmeisterschaft

























**2013 UCI MOUNTAIN BIKE
MARATHON WORLD CHAMPIONSHIPS**

**BRIXENTAL
AUSTRIA**

TECH LEXIKON

TECHNICAL DICTIONARY

	Innenlager bottom bracket		Federweg Gabel front travel		Rahmenhöhe framesize
	Bremshebel brake lever		Lenker handlebar		Vorderreifen front tire
	Bremsen brakes		Steuersatz headset		Sattelstütze seatpost
	Kassette cassette		Naben hubs		Schalthebel shifter
	Farbe color		Schaltwerk r. derailleur		Federelement shock
	Kurbel crankset		Hinterreifen rear travel		Speichen spokes
	Umwerfer f. derailleur		Federweg Dämpfer rear travel		Vorbau stem
	Gabel fork		Felgen rims	kg	Gewicht weight
	Rahmen frame		Sattel saddle		

CARBON RAHMEN UNFALL ERSATZ

carbon frame crash replacement

GHOST bietet, neben der drei bis fünfjährigen Garantie auf alle Rahmen, seit 2009 auch einen Austausch für beschädigte Carbon Rahmen an. Sollte der GHOST Rahmen nach einem Unfall oder Sturz so beschädigt sein, dass dieser nicht mehr fahrbar ist, kann unser Carbon Rahmen Unfall Ersatz Service in Anspruch genommen werden.

Die Abwicklung erfolgt über den GHOST Fachhändler, bei dem der Rahmen erworben worden ist. Dieser wird Sie gerne über die genaue Vorgehensweise informieren.

Since model year 2009, GHOST has offered a Carbon frame crash replacement in addition to its three to five year guarantee on all frames. You can claim this carbon frame crash replacement service if an accident or fall causes the GHOST frame damage such that continued riding is prevented.

The process takes place via the GHOST dealer from whom the frame was purchased. He or she will inform you of the entire process.

100% Bike Spaß in den Kitzbüheler Alpen.
Mehr als 800 Bike-Kilometer und viele Bike-Spezialisten erwarten Dich!



ERGONOMIE

ERGONOMICS

Ermittlung der passenden Rahmenhöhe

Ein GHOST Bike ist erst dann perfekt, wenn es mit den anatomischen Voraussetzungen seines Fahrers harmoniert. Ausschlaggebend hierfür ist die Wahl der richtigen Rahmenhöhe.

Zur Ermittlung über die Körpergröße verwenden Sie die nachfolgende Tabelle.

Bestimmen Sie Ihre Schrittlänge folgendermaßen:

- Gemessen wird die Schritthöhe ohne Schuhe und mit eng anliegender Kleidung.
- Als Hilfsmittel eignen sich ein Zollstock und eine Wasserwaage bzw. ein Buch.
- Wir empfehlen den aufrechten Stand mit dem Rücken zu einer Wand.
- Die Wasserwaage bzw. das Buch ist möglichst waagrecht zwischen den Beinen bis ganz nach oben zu ziehen.
- Der Abstand vom Boden bis zur Oberkante der Wasserwaage bzw. des Buchs entspricht nun der Schritthöhe.
- Der ermittelte Wert in Zentimeter ist mit folgenden Faktoren zu multiplizieren:
 - Faktor 0,57 für MTB und E-HYBRIDE
 - Faktor 0,66 für RACE und TREKKING
 - Faktor 0,61 für CROSS und SPEEDLINE
- Bei sportlicher Fahrweise ist vorzugsweise der kleinere Rahmen zu wählen.
- Bei tourenorientierter Fahrweise ist vorzugsweise der größere Rahmen zu wählen.

Dennoch: Die hier aufgeführten Angaben zur Ermittlung der Rahmenhöhe dienen nur zur Orientierung. Um wirklich sicher zu gehen, die richtige Rahmenhöhe gewählt zu haben, empfehlen wir in jedem Fall eine Probefahrt.

Ermittlung des Gesamtgewichts

Das Gesamtgewicht wird am einfachsten ermittelt, indem man sich in kompletter Radbekleidung und zusammen mit dem Fahrrad inklusive dessen Zuladung auf eine geeichte Waage stellt. Das Fahrrad ist dabei anzuheben. Die maximal zulässigen Gesamtgewichte entnehmen Sie der nachfolgenden Tabelle.

How to determine your frame size

A GHOST bike becomes the perfect bike when it is in harmony with its rider's anatomy. Selecting the right frame size is crucial for this process.

Please refer to the following table to determine the right frame size according to your height.

Please refer to the following information to determine the right frame size according to your inseam.

- Determining the length of your inseam is best done barefoot, wearing tight fitting clothing.
- Use a ruler and a level or a book.
- We recommend standing with your back against a wall.
- Hold the ruler or the book as horizontally as possible and pull it up between your legs as far as possible.
- Now measure from the floor to the top of your book or level. This measurement is your inseam.
- Multiply this number in centimeters by the following factors:
 - factor 0.57 (MTB and E-HYBRIDE)
 - factor 0.66 (RACE and TREKKING)
 - factor 0.61 (CROSS and SPEEDLINE)
- If you are an athletic rider you might prefer a slightly smaller frame.
- If you like longer trails you might prefer a slightly larger frame.

Please note that these methods of how to determine your frame size are guidelines only. We strongly recommend a test ride to make sure you selected the right frame size.

How to determine total weight

The easiest way to determine the total weight is by stepping, dressed in your riding gear, on a calibrated scale while lifting your bicycle with all accessories. The max. allowable total weights are listed in the following table.

Körpergröße
height

Rahmenhöhe
frame size

MTB, E-Hybride Trail

135 - 145 cm	34 cm
145 - 155 cm	40 cm
155 - 165 cm	44 cm
165 - 180 cm	48 cm
180 - 190 cm	52 cm
190 - 195 cm	56 cm

Race

155 - 160 cm	47 cm
160 - 165 cm	50 cm
165 - 175 cm	53 cm
175 - 180 cm	56 cm
180 - 185 cm	58 cm
185 - 190 cm	60 cm
190 - 195 cm	62 cm

Cross, E-Hybride Cross, Trekking, E-Hybride Trekking, Speedline

145 - 155 cm	45 cm
155 - 165 cm	49 cm
165 - 180 cm	53 cm
180 - 190 cm	57 cm
190 - 195 cm	61 cm

Cross Lady, E-Hybride Cross Lady, Trekking Lady, E-Hybride Trekking Lady, Trekking Wave, E-Hybride Wave

135 - 145 cm	40 cm
145 - 155 cm	44 cm
155 - 165 cm	48 cm
165 - 180 cm	52 cm
180 - 190 cm	56 cm

Körpergröße
height

Alter
age

Modell
model

Powerkid

135 cm ->	8 ->	24
120 cm ->	6 ->	20
100 cm ->	4 ->	16
95 cm ->	3 ->	12

Powerkiddy

90 cm ->	3 ->	12
----------	------	----

max. zulässiges Gesamtgewicht*

*max. allowed total weight**

MTB	120 kg
Downhill, Northshore	120 kg
4Cross, Dirt	120 kg
Trekking, E-Hybride	140 kg
Cross, Speedline	120 kg
Race	120 kg
Powerkid 24	100 kg
Powerkid 20	80 kg
Powerkid 16, 12	50 kg
Powerkiddy 12	25 kg

HINWEIS ZUM ZULÄSSIGEN GESAMTGEWICHT:

Beachten Sie unbedingt auch Einschränkungen des Laufrad- bzw. Felgenherstellers Tune!

ADDITIONAL INFORMATION REGARDING MAXIMUM ALLOWABLE WEIGHT:

Please also note wheel set and rim manufacturer Tune's restrictions!





GHOST INTERNATIONAL

GERMANY HEADOFFICE	<i>company</i> GHOST-Bikes GmbH <i>address</i> An der Tongrube 3, D - 95652 Waldsassen <i>phone</i> 0049 9632 9255-0 <i>fax</i> 0049 9632 9255-16 <i>mail</i> info@ghost-bikes.de <i>web</i> www.ghost-bikes.com	DENMARK	<i>company</i> C. Reinhardt as <i>address</i> Industriparken 21, 2750 Ballerup <i>phone</i> 0045 44830910 <i>fax</i> 0045 44680399 <i>mail</i> info@creinhardt.dk <i>web</i> www.ghost-bikes.dk
AUSTRIA	<i>company</i> Schretzmayer-Sport GmbH <i>address</i> Swobodastraße 1, 4664 Oberweis <i>phone</i> 0043 7612 73511 <i>fax</i> 0043 7612 73511 15 <i>mail</i> office@srt-sports.com <i>web</i> www.srt-sports.com	FINLAND	<i>company</i> PARMAX OY <i>address</i> MEIRAMIKUJA 1, 01510 VANTAA <i>phone</i> 00358 403042200 <i>fax</i> 00358 403042210 <i>mail</i> parmax@parmax.fi <i>web</i> www.parmax.fi
BELGIUM	<i>company</i> Sa brasseur <i>address</i> 13 rue de steppes, 4000 liege <i>phone</i> 0032 4 228 72 60 <i>fax</i> 0032 4 227 40 78 <i>mail</i> info.brasseur@skynet.be <i>web</i> www.brasseur-bicycles.com	FRANCE	<i>company</i> SOCIETE E.O.S. <i>address</i> 2 Rue H. de Mauduit, 22500 Paimpol <i>phone</i> 02 96 22 03 95 <i>fax</i> 02 96 22 01 23 <i>mail</i> france@ghost-bikes.com <i>web</i> www.ghost-bikes.com
BOSNIA HERZEGOVINA	<i>company</i> Dotea d.o.o. <i>address</i> Stjepana Radica 9, 88 000 Mostar <i>phone</i> 0038 736323290 <i>fax</i> 0038 736323290 <i>mail</i> dotea@tel.net.ba <i>web</i> www.dotea.ba	GREECE	<i>company</i> DynoBikes Ltd. <i>address</i> 415, Vouliagmenis Avenue, 16346 Ilioupoli - Athens <i>phone</i> 0030 210 990 1919 <i>fax</i> 0030 210 990 1919 <i>mail</i> info@dynocycles.com <i>web</i> www.dynocycles.com
CANADA	<i>company</i> Mountain Equipment Co-op <i>address</i> 149 West 4th Avenue, BC V5Y 4A6 Vancouver <i>phone</i> 001 8888470770 <i>mail</i> info@mec.ca <i>fax</i> - <i>web</i> www.mec.ca	HUNGARY	<i>company</i> Cseke Zrt. <i>address</i> Központi út 21-47, 1211 Budapest <i>phone</i> 0036 1 2785420 <i>fax</i> 0036 1 2785421 <i>mail</i> info@ghost-bikes.hu <i>web</i> www.ghost-bikes.hu
CHINA	<i>company</i> GHOST China Trading Co., Ltd. <i>address</i> 10J Room NO. 108 Ruijun Building Central, Road Shajing Shenzhen 518125 China <i>phone</i> 0086 755 23200080 <i>fax</i> 0086 755 23200081 <i>mail</i> ghost@accell.com.tw <i>web</i> -	INDONESIA	<i>company</i> PT. Wira Roda Nusantara <i>address</i> Jalan Jalur Sutera Ruko Element Blok 25 B-C No A3, Alam Sutera, Tangerang, 15325 <i>phone</i> 0062 21 3388 8888 <i>fax</i> - <i>mail</i> indonesia@ghost-bikes.com <i>web</i> -
CROATIA	<i>company</i> OZON SPORT d.o.o. <i>address</i> Zagrebacka cesta 145a, HR-10000 Zagreb <i>phone</i> 00385 (0)98 395 807 <i>fax</i> 00385 (0)1 382 11 67 <i>mail</i> info@ozonsport.hr <i>web</i> www.ozonsport.hr	ITALY	<i>company</i> Schretzmayer Sport GmbH by Krauti Bike <i>address</i> Karerseestraße - Via Carezza 40, I-39056 Welschnofen - Nova Levante <i>phone</i> 0039 0471 613 046 <i>fax</i> 0039 0471 614 263 <i>mail</i> italy@srt-sports.com <i>web</i> www.srt-sports.com
CYPRUS	<i>company</i> Tasos Aletras Ltd <i>address</i> 266 Tseriou Street, 2044 Strovolos Nicosia <i>phone</i> 0035 722321015 <i>fax</i> 0035 722321731 <i>mail</i> aleandr@cytanet.com.cy <i>web</i> www.aletras-megabike.com	LATVIA	<i>company</i> ELKOR <i>address</i> 201 Brivibas str., 1039 Riga <i>phone</i> 00371 67070707 <i>fax</i> 00371 67070708 <i>mail</i> info@elkor.lv <i>web</i> www.elkor.lv
CZECH REPUBLIC	<i>company</i> Schindler spol. s r.o. <i>address</i> Slezská 101/112, 747 27 Koberice <i>phone</i> 00420 725792420 <i>fax</i> - <i>mail</i> info@ghost-bikes.cz <i>web</i> www.ghost-bikes.cz	LITHUANIA	<i>company</i> UAB VELOMA <i>address</i> TAIKOS PR. 21, Klaipeda <i>phone</i> 0037 062096160 <i>fax</i> 0037 046380837 <i>mail</i> info@veloma.lt <i>web</i> www.veloma.lt

LUXEMBOURG	<i>company</i> <i>address</i> <i>phone</i> <i>fax</i> <i>mail</i> <i>web</i>	Benelux-Bikes Atlantis 45, 7821 AX Emmen 0031 591 623450 0031 591 623460 info@ghost-bikes.nl www.benelux-bikes.nl	SPAIN	<i>company</i> <i>address</i> <i>phone</i> <i>fax</i> <i>mail</i> <i>web</i>	BASOLI, S.A. C/ Alfons IV, 61, 08402 Granollers 0034 93 8604534 0034 93 8600746 personal@basoli.com www.basoli.es
NORWAY	<i>company</i> <i>address</i> <i>phone</i> <i>fax</i> <i>mail</i> <i>web</i>	Skalstad Sykkel Storgt 35 , 3611 Kongsberg 0047 32722011 - skalstad.sykkel@gmail.com www.skalstad.no	SWEDEN	<i>company</i> <i>address</i> <i>phone</i> <i>fax</i> <i>mail</i> <i>web</i>	C. Reinhardt as Industriparken 21, 2750 Ballerup 0045 44830910 0045 44680399 info@creinhardt.dk www.ghost-bikes.dk
POLAND	<i>company</i> <i>address</i> <i>phone</i> <i>fax</i> <i>mail</i> <i>web</i>	Secesja Sp.J. 30-552 Kraków, ul.Wielicka 8 0048 12 6562091 0048 12 6565759 secesja@secesja.pl www.ghost.com.pl	SWITZERLAND	<i>company</i> <i>address</i> <i>phone</i> <i>fax</i> <i>mail</i> <i>web</i>	OFELEC AG Hübelacherstr. 1, 5242 Lupfig 0041 562020081 0041 562020082 info@ofelec.ch www.ofelec.ch
PORTUGAL	<i>company</i> <i>address</i> <i>phone</i> <i>fax</i> <i>mail</i> <i>web</i>	BASOLI, S.A. C/ Alfons IV, 61, 08402 Granollers 0034 93 8604534 0034 93 8600746 personal@basoli.com www.basoli.es	TAIWAN	<i>company</i> <i>address</i> <i>phone</i> <i>fax</i> <i>mail</i> <i>web</i>	Accell Asia Taiwan Co., Ltd. 24F-3, NO. 123, Sec. 3, Taichung Port Road, Xitun Dist., Taichung City 40767, Taiwan 00886 4 23599500 00886 4 23595887 ghost@accell.asia -
ROMANIA	<i>company</i> <i>address</i> <i>phone</i> <i>fax</i> <i>mail</i> <i>web</i>	S.C. Explorer SRL Str. Turnului Nr. 13, 550197 Sibiu 0040 269216641 0040 269216641 voinescu@explorersport.ro www.explorersport.ro	THE NETHERLANDS	<i>company</i> <i>address</i> <i>phone</i> <i>fax</i> <i>mail</i> <i>web</i>	Benelux-Bikes Atlantis 45, 7821 AX Emmen 0031 591 623450 0031 591 623460 info@ghost-bikes.nl www.benelux-bikes.nl
SLOVAKIA	<i>company</i> <i>address</i> <i>phone</i> <i>fax</i> <i>mail</i> <i>web</i>	Schindler spol. s r.o. Slezská 101/112, 747 27 Koberice 00421 908728967 - info@ghost-bikes.sk www.ghost-bikes.sk	TURKEY	<i>company</i> <i>address</i> <i>phone</i> <i>fax</i> <i>mail</i> <i>web</i>	Accell Bisiklet San ve Tic. A.S. Organize Sanayi bölgesi 3.kısım, Ahmet Tütüncüoğlu cad.no1, Manisa/TURKEY, ZIP Code 45030 0090 236 2130045 0090 236 2130050 info@accellbisiklet.com.tr www.accellbisiklet.com.tr
SLOVENIA	<i>company</i> <i>address</i> <i>phone</i> <i>fax</i> <i>mail</i> <i>web</i>	Griffin Robert Bezenšek s.p. Linhartova 18 0038 6 3 492 63 33 - info@ghost.si www.ghost.si	UK	<i>company</i> <i>address</i> <i>phone</i> <i>fax</i> <i>mail</i> <i>web</i>	Hotlines Europe Unit 17, The Loan, Viewforthbank Industrial Estate, South Queensferry, EH 30 9SD 0044 131 319 1444 0044 131 319 2070 info@hotlines-uk.com www.hotlines-uk.com
SOUTH AFRICA	<i>company</i> <i>address</i> <i>phone</i> <i>fax</i> <i>mail</i> <i>web</i>	Ballistic Bike Trading Kimbult Industrial Office Park, Block B, Unit 8, Zeiss Road, Laserpark, Honeydew, 2170 0027 110234478 086 5679722 jason@bbtrading.co.za www.bbtrading.co.za	UKRAINE	<i>company</i> <i>address</i> <i>phone</i> <i>fax</i> <i>mail</i> <i>web</i>	Tais-E Ltd Vasilkovskaya str. 23/16 03022 Kiev 0038 044 2570294 0038 044 4942335 serg@tais.kiev.ua www.velosprint.ua
SOUTH KOREA	<i>company</i> <i>address</i> <i>phone</i> <i>fax</i> <i>mail</i> <i>web</i>	Accell Asia Korea Rn# 104, Kyunghyup Bldg., Seongsudong2-Ga 273- 24, Seongdong-Ku, Seoul, South Korea 0082 2 499 4649 0082 2 469 4649 admin@ghostkorea.com www.ghostkorea.com			

IMPRESSUM

PHOTOS STUDIO

Fotostudio Jahreiss
Hohenberg

PHOTOS ACTION & LIFESTYLE

Michael Müller
KME Studio

LAYOUT & SATZ

Julian Lemme
Catharina Heinzl

PRINT

Aumüller Druck GmbH & Co. KG
Regensburg

THANKS TO

Michi, Martin, Anita, Dani, Oli, Anja, Mauro, Silke, Stephan, Maarten, Hacky,
Christina, Leon, Julian, Guido, Marcus, Fischi, Adam, Vroni, Martin, Reserl, Andy,
Martin & Stepan

Maloja, Odlo, Platzangst, Evoc, Vaude

Irrtümer, Änderungen, Druckfehler vorbehalten.
Bilder können vom Original abweichen.

*Subjects to change without prior notice, errors and misprints excepted.
Pictures could be different from the original.*

Die gedruckten Produkte sind nicht in allen Regionen erhältlich,
bitte kontaktieren Sie Ihren lokalen GHOST Händler.

*Products shown may not be available in all regions,
please check with your local GHOST retailer.*

Geschäftsführung:
Klaus Möhwald
René Takens

GHOST-Bikes GmbH
An der Tongrube 3
D-95652 Waldsassen

Tel: +49 (9632) 9255 - 0
Fax: +49 (9632) 9255 - 16
info@ghost-bikes.com

Member of Accell Group



WWW.GHOST-BIKES.COM

